

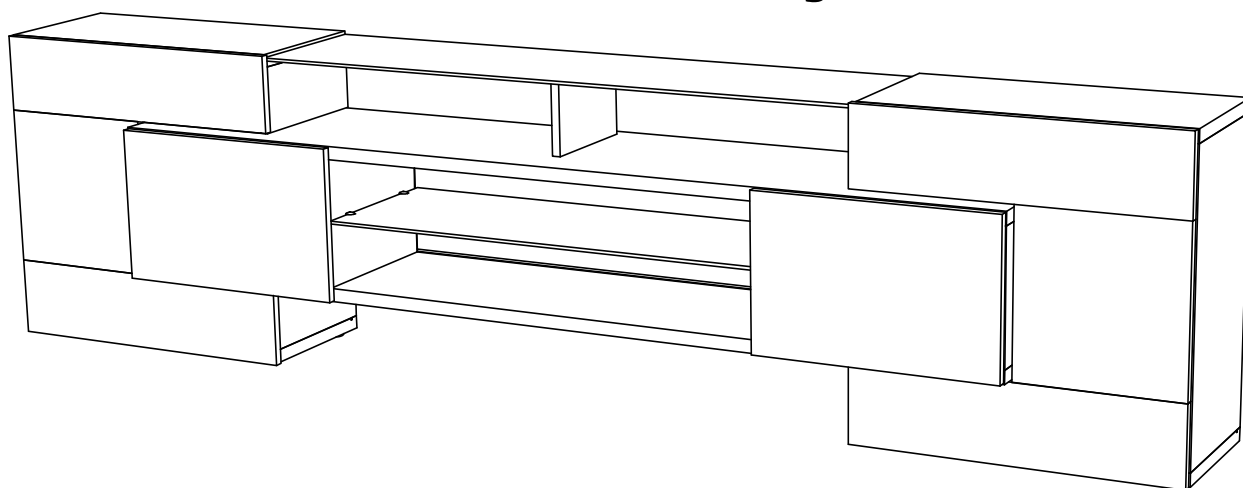

MAX. 25 Kg



DE

Montageanleitung

GB USA

Assembly instructions

FR

Notice de montage

I

Istruzione di montaggio

NL

Handleiding voor de montage

PL

Instrukcja montażu

CZ

Montážní návod

SK

Návod na montáž

HU

Szerelési útmutató

RO

Instrucțiuni de montaj

TR

Montaj talimatı

RU

Инструкция по монтажу

PT

Instruções de montagem

ES

Instrucciones de montaje

AR

تعليمات التجميع

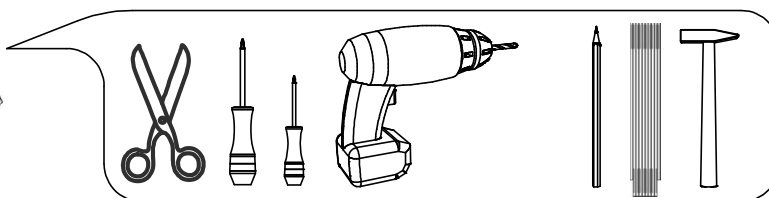
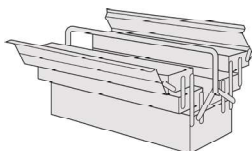
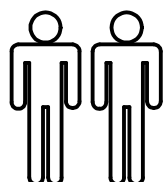

IT**Avvisi di sicurezza**

Durante il montaggio del mobile, il triangolo segnala i seguenti avvisi.

**8**

Non superare i limiti di carico suggeriti, per evitare il danneggiamento del mobile.

12

Tenere lontano dai bambini pezzi di ferramenta come viti, copriviti ecc. per evitare un eventuale soffocamento.

13

Seguire scrupolosamente lo schema di montaggio.

19

Il montaggio deve essere effettuato da personale qualificato. Se non viene effettuato correttamente, il prodotto può ribaltarsi o cadere, danneggiando persone o cose. Poiché ci sono pareti di materiali diversi, le viti per il fissaggio alla parete non sono incluse. Per scegliere gli accessori di fissaggio adatti, rivolgetevi a un rivenditore locale.

DE**Sicherheitshinweise**

Das Dreieck erinnert Sie während der Montage an die folgenden Hinweise.

**8**

Überschreiten Sie nicht die angegebenen Maximalbelastungen. Andernfalls kann das Möbelstück beschädigt oder zerstört werden.

12

Achten Sie darauf, daß Kinder keine Kleinteile, wie z. B. Muttern, Abdeckkappen oder Ähnliches in den Mund nehmen. Sie könnten sie verschlucken und daran ersticken.

13

Gehen Sie bei der Montage des Artikels sorgfältig vor und halten Sie sich an die Montageanleitung.

19

Fachkundige Montage erforderlich. Unsachgemäße Montage kann zu Unfällen führen. Da es viele verschiedene Wandmaterialien gibt, sind Schrauben für die Wandbefestigung nicht beigegeben. Ggf. sollte man sich beim Eisenwarenfachhandel nach geeignetem Befestigungsmaterial erkundigen.

UK**USA****Safety instructions**

The triangle reminds you during the installation of the following notes.

**8**

Do not exceed the maximum loads specified. Otherwise, the furniture may sustain damage or be irreparably damaged.

12

Ensure that children do not put any small parts such as nuts, caps or the like in their mouth. They could swallow and choke on them.

13

When assembling the product, please proceed with caution and comply with the assembly instructions.

19

Assembly should be carried out by a qualified person, because wrong assembly may lead to that the furniture will topple over and cause injury or damage. As wall materials vary, screws for fixing to wall are not included. For advice on suitable screw systems, contact your local specialised dealer.

RU**Правила техники безопасности**

Во время монтажа треугольник служит напоминанием для следующих указаний.

**8**

Не допускается превышение указанных максимальных нагрузок. В противном случае возможно повреждение или разрушение мебели.

12

Следите, чтобы мелкие детали, например гайки, крышки и т. п., не попали в рот ребенка. Дети могут их проглотить и задохнуться.

13

При монтаже изделия будьте внимательны и соблюдайте инструкции по монтажу.

19

Монтажът трябва да бъде извършен от специалист, тъй като неправилният монтаж може да доведе до прекатурване и да причини нараняване или повреда. Поради разнообразието от стенни материали винтовете за прикрепяне към стената не са осигурени. Свържете се със специализиран доставчик за съвет относно подходящи прикрепващи механизми.

CZ**Bezpečnostní pokyny**

Trojúhelník vám během montáže připomene následující pokyny.

**8**

Nepřekračujte uvedená maximální zatížení. V opačném případě může dojít k poškození nebo zničení nábytku.

12

Dbejte na to, aby děti nedávaly do úst žádné drobné díly jako např. matice, krytky a podobně. Mohly by je spolknout a udusit se.

13

Při montáži výrobku postupujte pečlivě a dodržujte pokyny uvedené v montážním návodu.

19

Montáž by měla být provedena kvalifikovanou osobou - nesprávné provedení může vést k převrnutí nábytku a způsobit úraz nebo destrukci. Pro různé zdící materiály nejsou šroubky a uchycení obsaženy v balení. O vhodném připevnění se poraďte s odborným prodejcem.

FR**Avis de sécurité**

Ces avis vous seront rappelés durant le montage par ce triangle.

**8**

Ne pas dépasser la charge maximum indiquée cela endommagerait irréremédiablement votre meuble.

12

Tenir éloignés les enfants pour éviter qu'ils ne mettent pas de petites pièces dans leur bouche, ils pourraient les avaler et étouffer.

13

Durant le montage de votre meuble veuillez procéder avec prudence et respecter les instructions de montage.

19

Le montage doit être effectué par une personne compétente. Un montage mal effectué peut provoquer la chute du meuble et blesser quelqu'un. Les vis et ferrures pour fixer le meuble au mur ne sont pas incluses. Choisissez des vis et ferrures adaptées au matériau de votre mur. En cas de doute, demandez conseil à un vendeur spécialisé.

TR

Güvenlik uyarıları

Durante a montagem do móvel, o triângulo indica as seguintes advertências.

**8**

Belirtilen azami yük değerini aşmayınız, aksi takdirde mobilya parçası zarar görebilir veya kullanılamaz hale gelebilir.

12

Çocukların somun, muhafaza kapakçıkları ve benzeri küçük parçaları ağızları na almamalarına dikkat ediniz. Bunları yutabilirler ve boğulabilirler.

13

Montaj esnasında büyük bir itina ile çalışınız, ürünle dikkatlice çalışınız ve mutlaka montaj talimatına uyunuz.

19

Montaj, yetkili bir kişi tarafından yapılmalıdır. Yanlış montaj mobilyanın düşmesine ve yaralanma veya hasara yol açabilir. Duvar yapı malzemeleri farklılık göstereceğinden duvar montajı vidaları dahil değildir. Uygun bir vida sistemi için ilgili araç-gerçeri satan dükkanlara başvurunuz.

SK

Bezpečnostní pokyny

Trojuhelník vám počas montáže pripomenie nasledujúce pokyny.

**8**

Neprekročte uvedené maximálne zaťaženia. V opačnom prípade sa môže nábytok poškodiť alebo zničiť.

12

Dbajte, aby si deti nemohli dať do úst drobné diely, ako napr. matice, krytky alebo podobne. Mohli by ich prehltnúť a zadusiť sa.

13

Pri montáži výrobku postupujte obozretne a dodržujte návod na montáž.

19

Pohľadovo najsestavľiva za to usposobljena oseba, saj se lahko nepravilno sestavljen pohľadovo prevrne in povzroči telesne poškodbe ali materialno škodo. Ker se stenski materiali razlikujejo, vijaki niso priloženi. Za nasvet glede primerne vrste vijakov se obrnite na najbližjo specializirano trgovino.

NL

Veiligheidsinstructies

De driehoek herinnert u tijdens de installatie van de volgende meldingen.

**8**

Overschrijd de aangegeven maximale belastingen niet. Anders kan het meubelstuk worden beschadigd of vernield.

12

Zorg ervoor dat kinderen geen kleine stukken, zoals moeren, afdekkapjes of dergelijke in de mond nemen. Ze kunnen ze inslikken en daardoor stikken.

13

Ga bij de montage van het artikel zorgvuldig te werk en houd u aan de handleiding voor de montage.

19

De montage dient te worden uitgevoerd door een vakbekwaam iemand. Foutieve montage kan ertoe leiden dat het meubel omvalt, waardoor er persoonlijk letsel of schade kan ontstaan. Omdat er veel verschillende wandmaterialen bestaan, zit er geen wandbeslag bijgesloten. Voor advies over geschikt wandbeslag, neem contact op met de vakhandel.

PL

Wskazówki bezpieczeństwa

Trójkąt przypomina o następujących wskazówkach dotyczących montażu.

**8**

Nie wolno przekraczać podanych maksymalnych wartości obciążenia. W przeciwnym razie mebel może zostać uszkodzony lub zniszczony.

12

Należy dopilnować, aby dzieci nie bawiły się lub też brały do ust żadnych drobnych części mebla, takich jak np. nakrętki, zatyczki itp.. Mogłyby je połknąć i udusić się nimi.

13

Podczas montażu proszę postępować z należytą uwagą i zgodnie z instrukcją montażu. Artykuł może być montowany tylko przez osoby z odpowiednimi kwalifikacjami.

19

Montaż powinien być przeprowadzany przez wykwalifikowaną osobę, ponieważ złe zmontowanie może spowodować zniszczenie mebla lub może wyrządzić szkodę domownikom. Ponieważ w każdym pomieszczeniu ściany mogą być wykonane z innego materiału, komplet nie zawiera żadnych wkrętów ani umocowań. Aby zasięgnąć porady w kwestii wyboru odpowiednich wkrętów skontaktuj się z lokalnym sklepem specjalistycznym.

RO Instrucțiuni referitoare la siguranță

Triunghiul vă atenționează să țineți cont în timpul montajului de următoarea indicație



8

Nu depășiți solicitările maxime specificate. Altfel puteți să deteriorați sau să distrugeți piesa de mobilier.

12

Supravegheați copiii pentru că pot să introducă în gură piesele mici, cum ar fi de exemplu piulițe, capace sau altele similare. Ei pot să le înghită și se pot asfixia.

13

Procedați cu atenție la montarea produsului și respectați instrucțiunile de montaj.

19

Se recomandă ca montarea să fie realizată de o persoană calificată; asamblarea greșită poate determina desprinderea mobilierului, deteriorarea lui și chiar producerea de accidente. Instrucțiunile materialele din care sunt construiți pereții variază, șuruburile pentru fixarea pe perete nu sunt incluse. Contactează dealer-ul tău local pentru consiliere.

HU Biztonságtechnikai

A háromszög a szerelés közben a következő utasításra emlékezteti.



8

Tartsa be az engedélyezett maximális terhelhet séget / teljesítményt. Különben a bútor és annak alkatrészei megsérülhetnek, tönkre mehetnek.

12

Gondoskodjon arról, hogy a gyerekek ne vehessék a szájukba a kis alkatrészeket, pl. az anyákat, a fed kupakokat stb. Ezeket lenyelve megfulladhatnak.

13

A termék összeszerelésekor körültekint en járjon el, és tartsa magát a szerelési útmutatóban foglaltakhoz.

19

Az összeszerelést ajánlatos képzett szakemberre bízni, mert a helytelen összeszerelés következtében a bútor felborulhat és sérülést okozhat. Mivel a fal anyaga lakásonként / otthononként eltérő lehet, a rögzítéshez szükséges csavarokat a csomag nem tartalmazza. A megfelelő csavar kiválasztásáért kérj tanácsot az áruházban a szakképzett személyzettől.

PT Avisos de segurança

Durante a montagem do móvel, o triângulo indica as seguintes advertências.



8

Não ultrapasse os limites de carga recomendados, para evitar danos no móvel.

12

Mantenha longe do alcance das crianças todo o tipo de peças pequenas como parafusos e outras, para evitar o risco de sufocamento.

13

Siga escrupulosamente o esquema de montagem.

19

Montaje a realizar por montador autorizado, pues un montaje erróneo puede resultar en una caída del mueble, causando daños a personas o cosas. Como hay muchas clases de materiales de pared, no se incluyen los tornillos de montaje. Para sugerencias sobre sistemas de colocación adecuados, ponte en contacto con tu especialista más cercano.

ES Avisos de seguridad

Durante el montaje del mueble, prestar atención al triángulo que informa sobre los siguientes avisos.



8

No exceder los límites de carga aconsejados, para evitar daños al mueble.

12

Mantener alejado de los niños piezas de herramientas como tornillos, ecc para evitar una eventual asfixia.

13

Seguir escrupulosamente el diagrama de montaje.

19

A montagem deverá ser realizada por uma pessoa qualificada, porque uma montagem incorreta pode ocasionar que o móvel caia e cause lesões ou estragos. Como os materiais de parede variam, os parafusos para fixar à parede não estão incluídos. Para obter conselho sobre o sistema de parafusos adequado, consulte o seu retalhista local especializado.

AR إشعارات الأمان

من فضلك اتبع الخطوات التالية الموضحة أدناه لكيفية التركيب و المرموز لها بالمثلثات الصفراء أسفله



8

رجاء لا تتجاوز الحد الأقصى المسموح للأحمال والأسوف ينجر عن ذلك أضرار يمكن لأن تصل لدرجة التلف أو الكسر

12

تأكد من ابعاد الأجزاء الصغيرة و المسامير و البراغي التي يمكن ابتلاعها من أيدي الأطفال

13

عند تجميع و تركيب المنتج يرجى اتباع الخطوات المنصوص عليها بدقة و حذر

19

من الأفضل الاستعانة بشخص مؤهل أو مختص في تركيب الأثاث لأن التركيب الخاطئ قد ينتج عنه السقوط أو التلف أو الكسر و قد يسبب إصابات. كما أن المختص سوف يعرف تمامًا نوع المسامير و البراغي المناسبة لأسطحك والتي قد تكون غير متناسبة مع البراغي و المسامير المرفقة

12

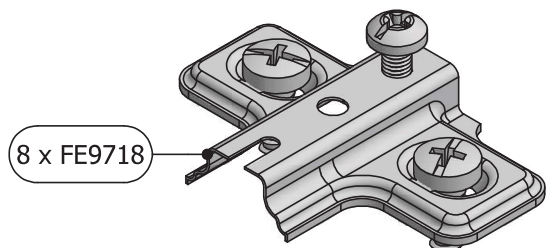
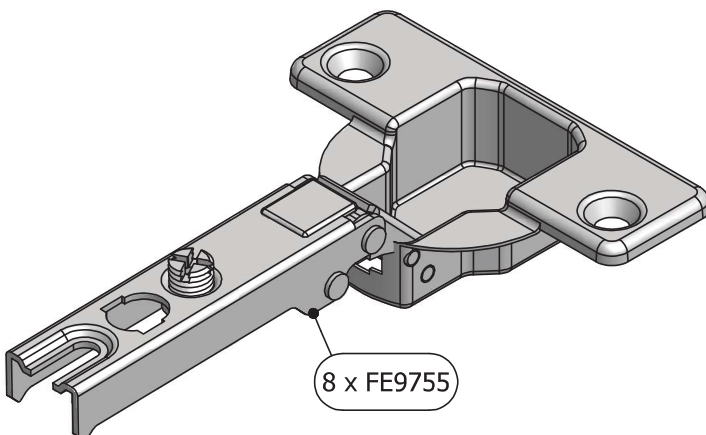
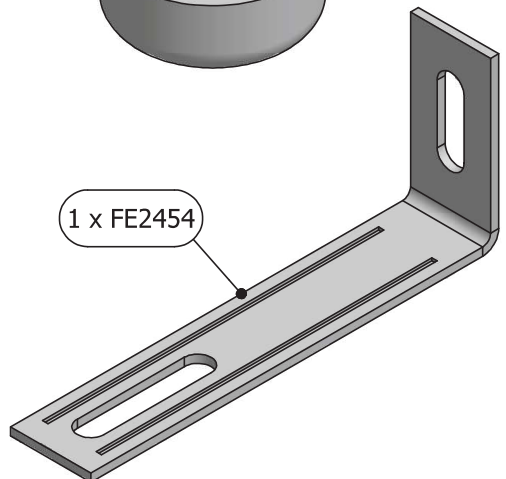
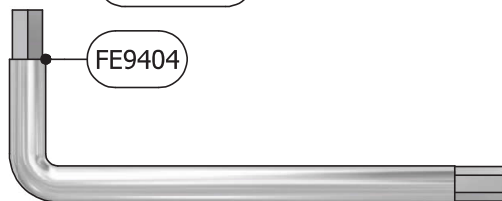
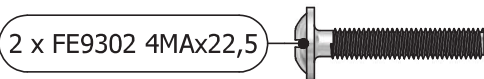
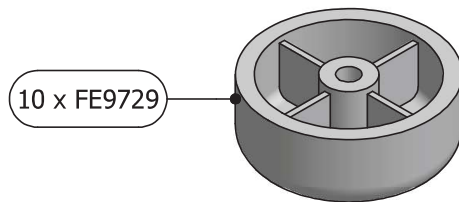
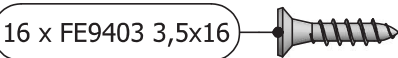
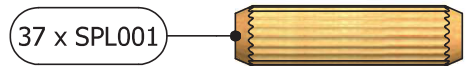
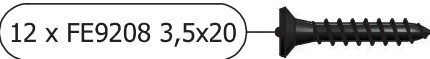
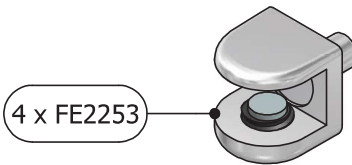
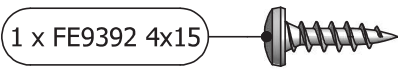
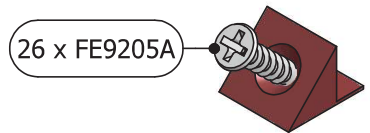
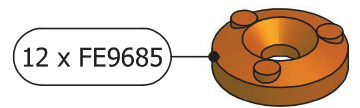
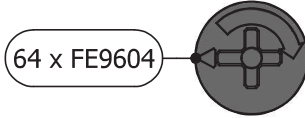
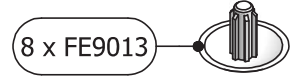
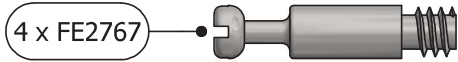
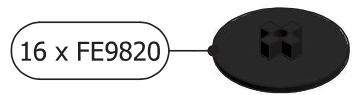
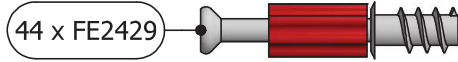
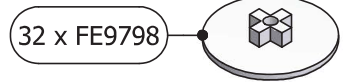

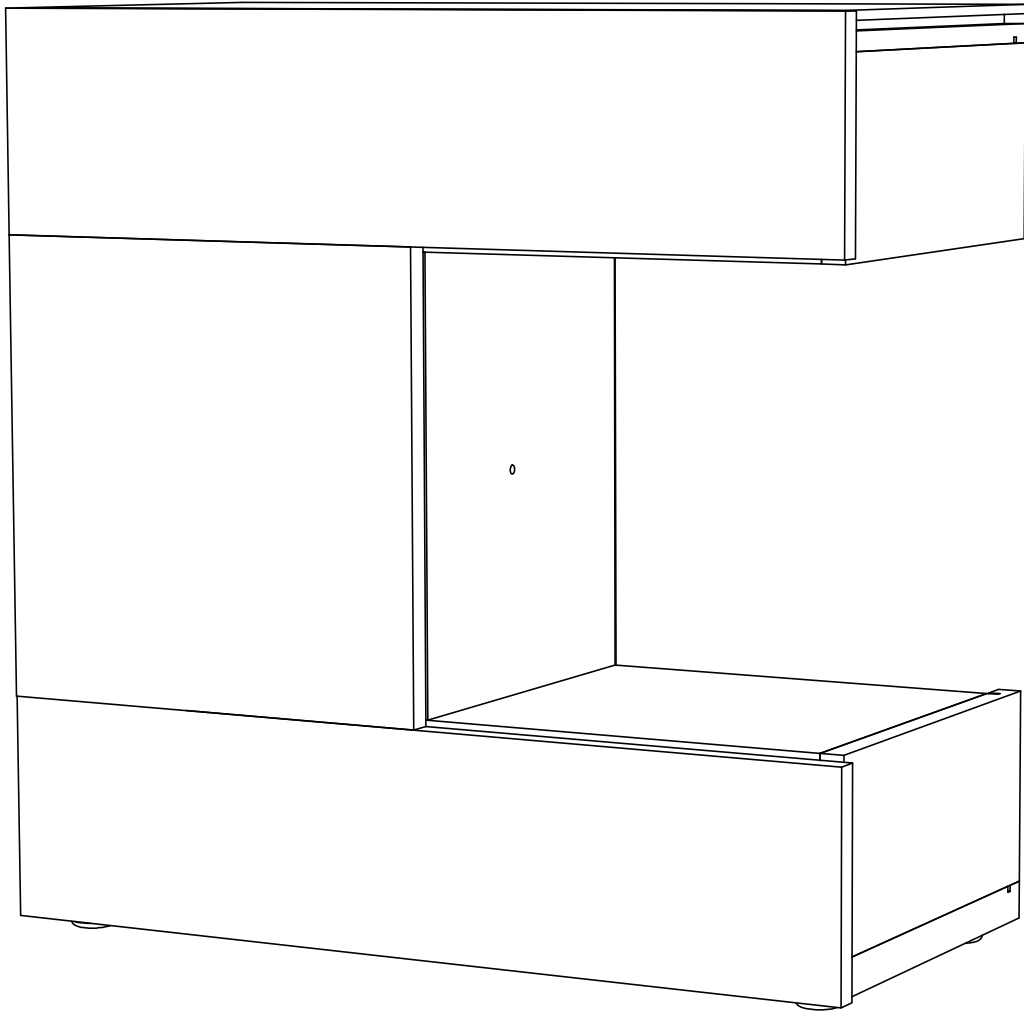

DE

Montageanleitung

FR

Notice de montage

NL

Handleiding voor de montage

CZ

Montážní návod

HU

Szerelési útmutató

TR

Montaj talimatı

PT

Instruções de montagem

AR

تعليمات التجميع

GB USA

Assembly instructions

I

Istruzione di montaggio

PL

Instrukcja montażu

SK

Návod na montáž

RO

Instrucțiuni de montaj

RU

Инструкция по монтажу

ES

Instrucciones de montaje

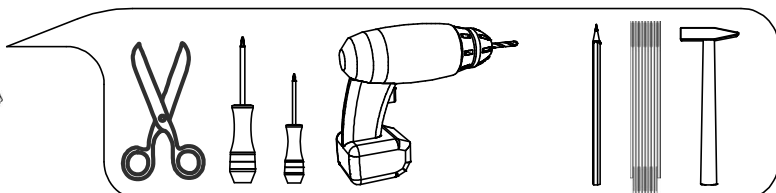
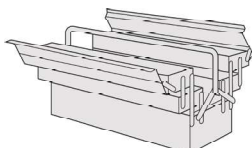
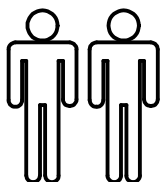

Service • Dienstverlening • Serwis • Servis • Сервисная служба • Servizio

Name • Naam • Nazwa • İsim • Название • Nom • Nome

Nr. • No. • Номер • Nu.

Тур • Туре • Тір • Тип • Тіро

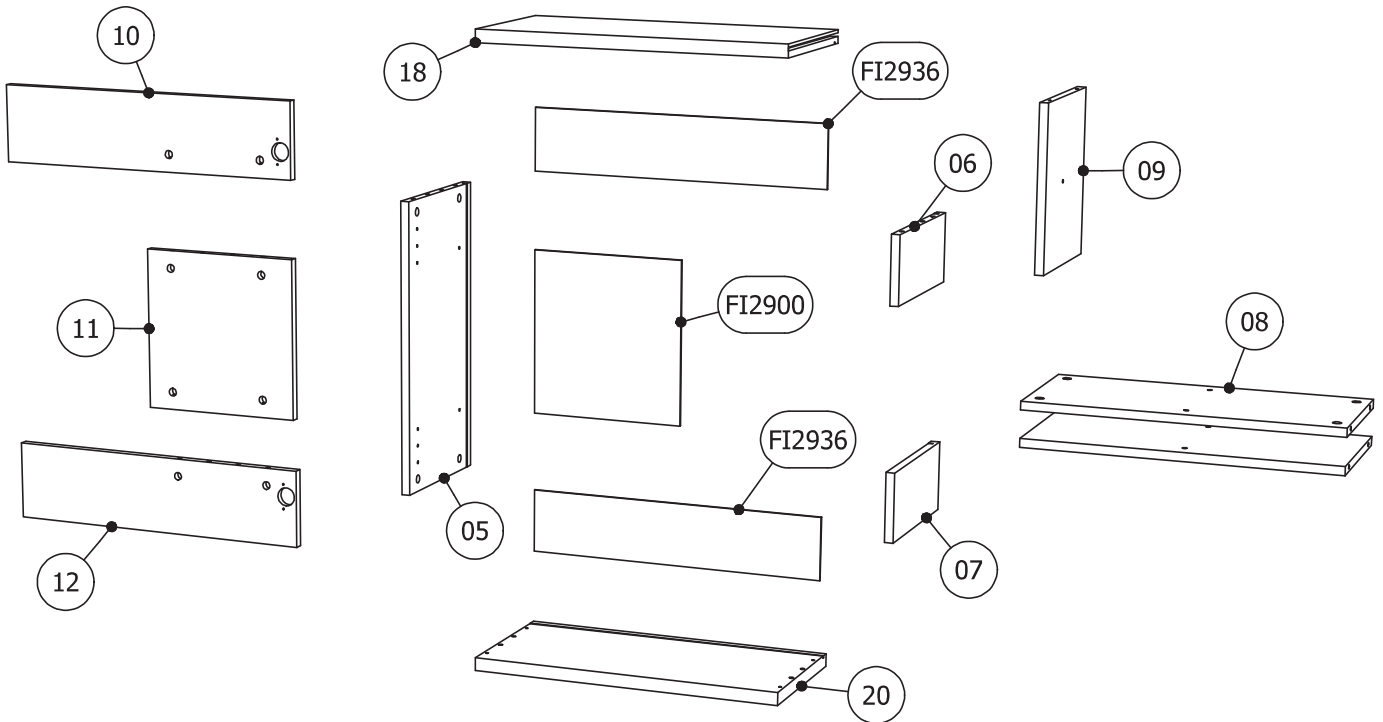
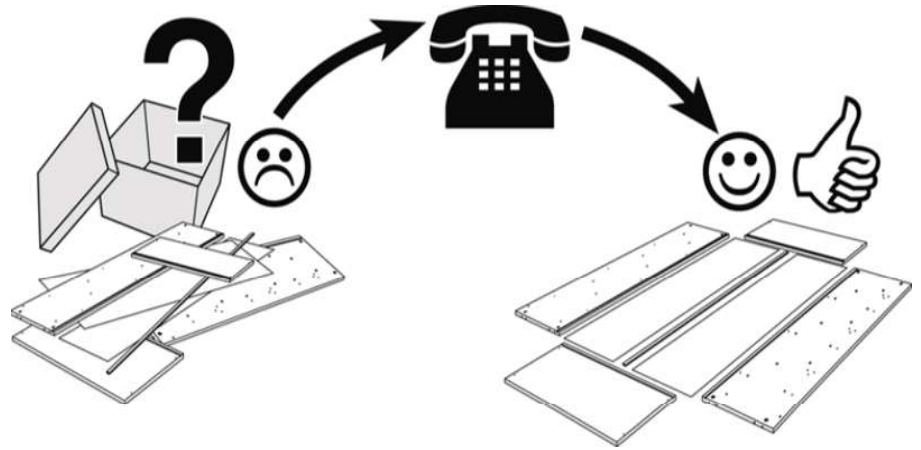

Code	Qt.	Dimensions	Box	Code	Qt.	Dimensions	Box
05	1	556x282x16	2-1	11	1	308x305x16	2-2
06	1	128x282x16	2-1	12	1	149x605x16	2-2
07	1	128x282x16	2-1	18	1	600x282x25	2-1
08	2	568x262x16	2-1	20	1	600x282x25	2-1
09	1	300x262x16	2-1	FI2900	1	318x298x3	2-2
10	1	149x605x16	2-2	FI2936	2	122x582x3	2-2

13

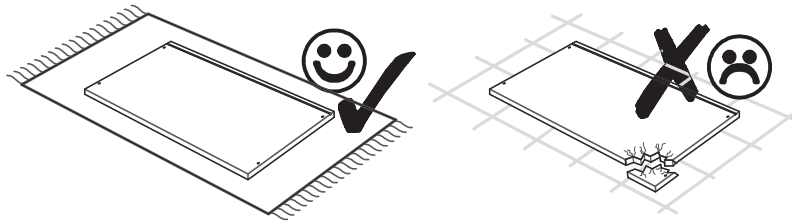

6 x SPL001



8 x FE2429



4 x FE9718

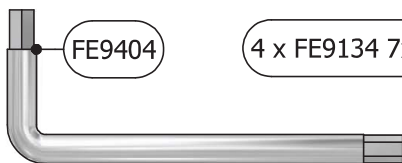
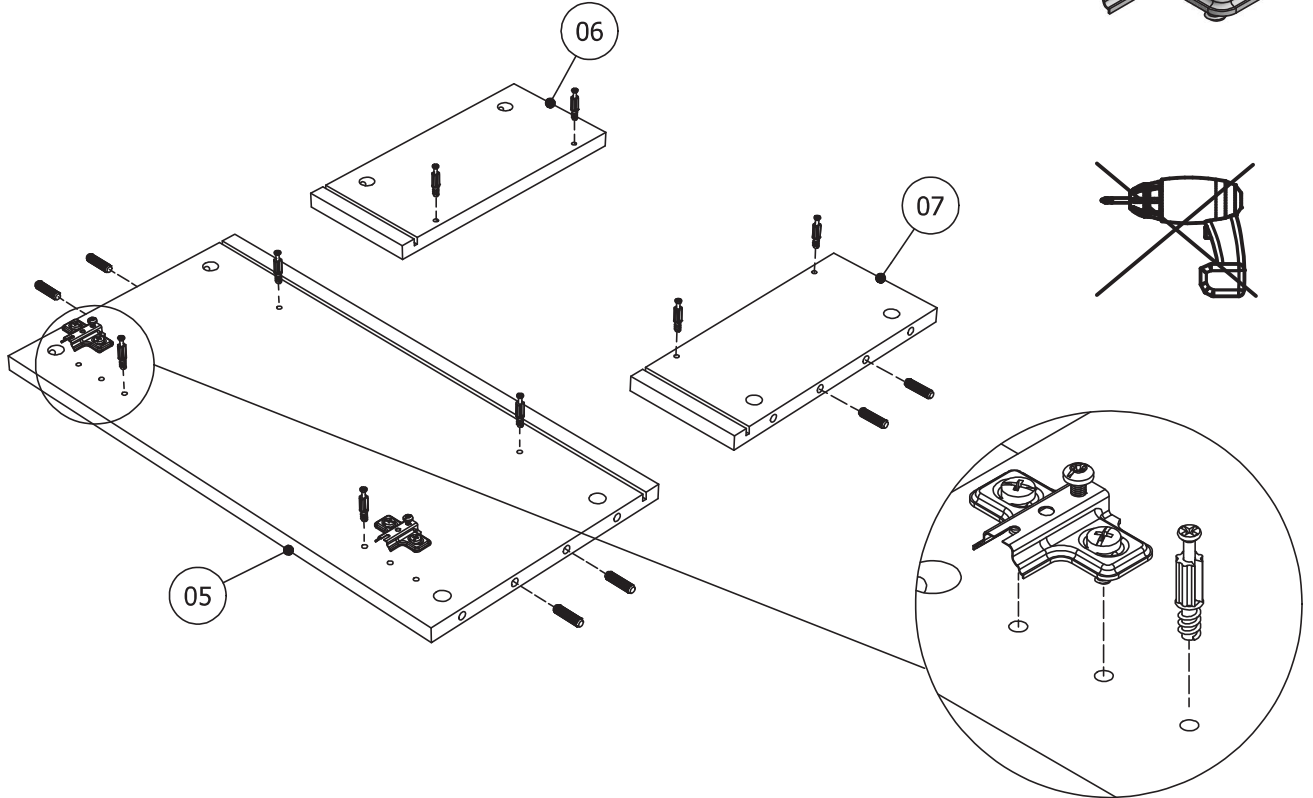
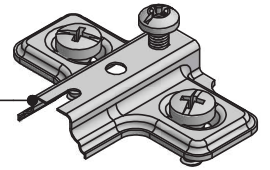

FE9404

4 x FE9134 7x50

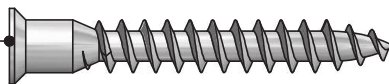

4 x FE9013

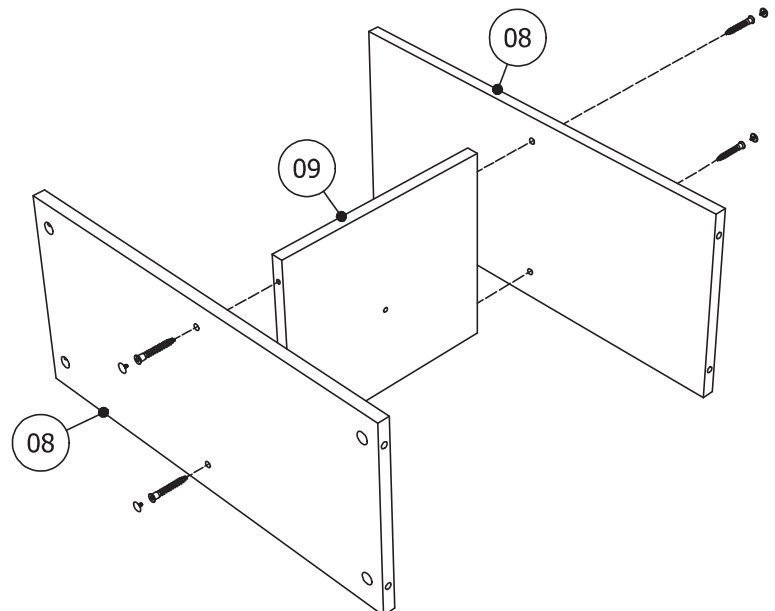

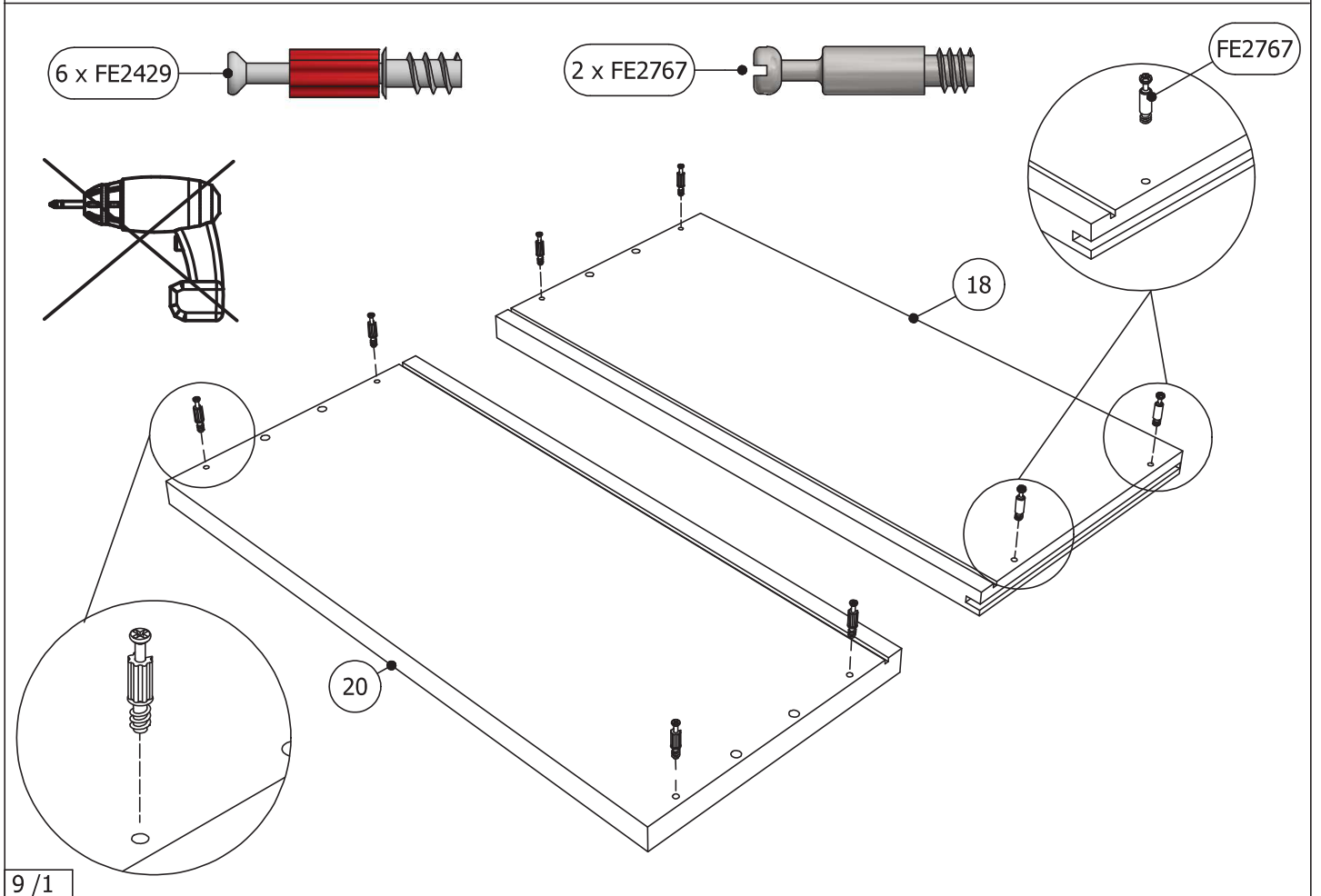
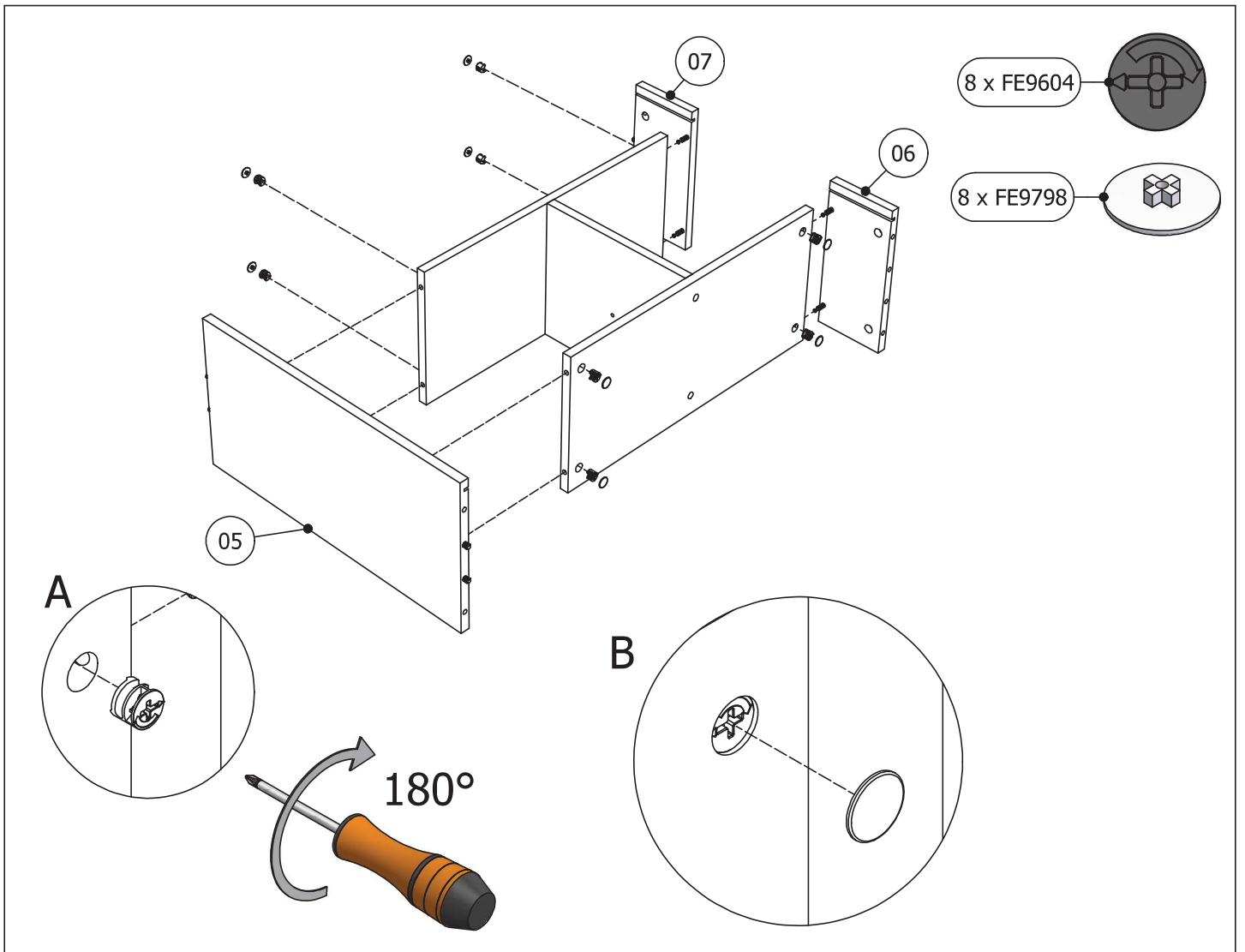

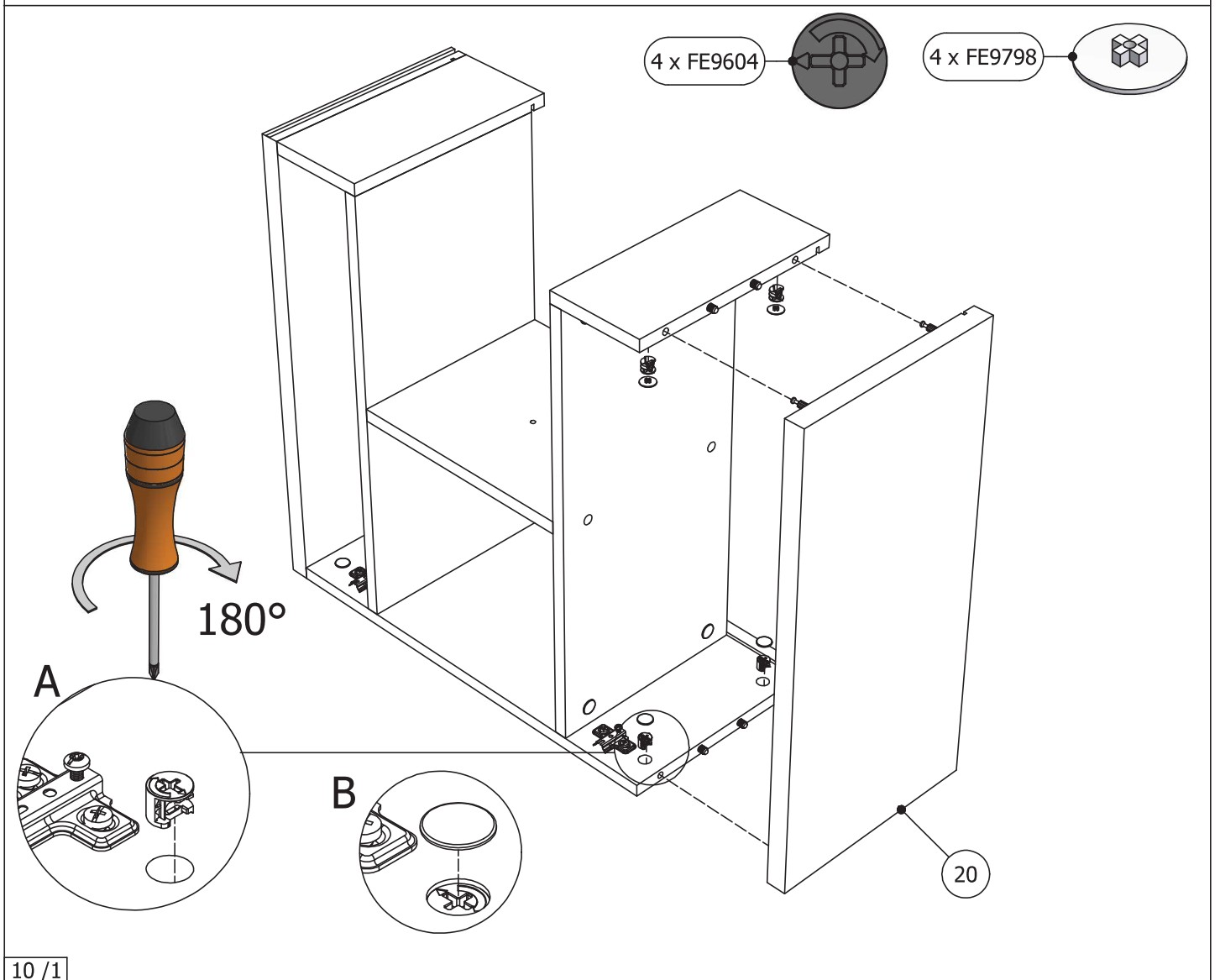
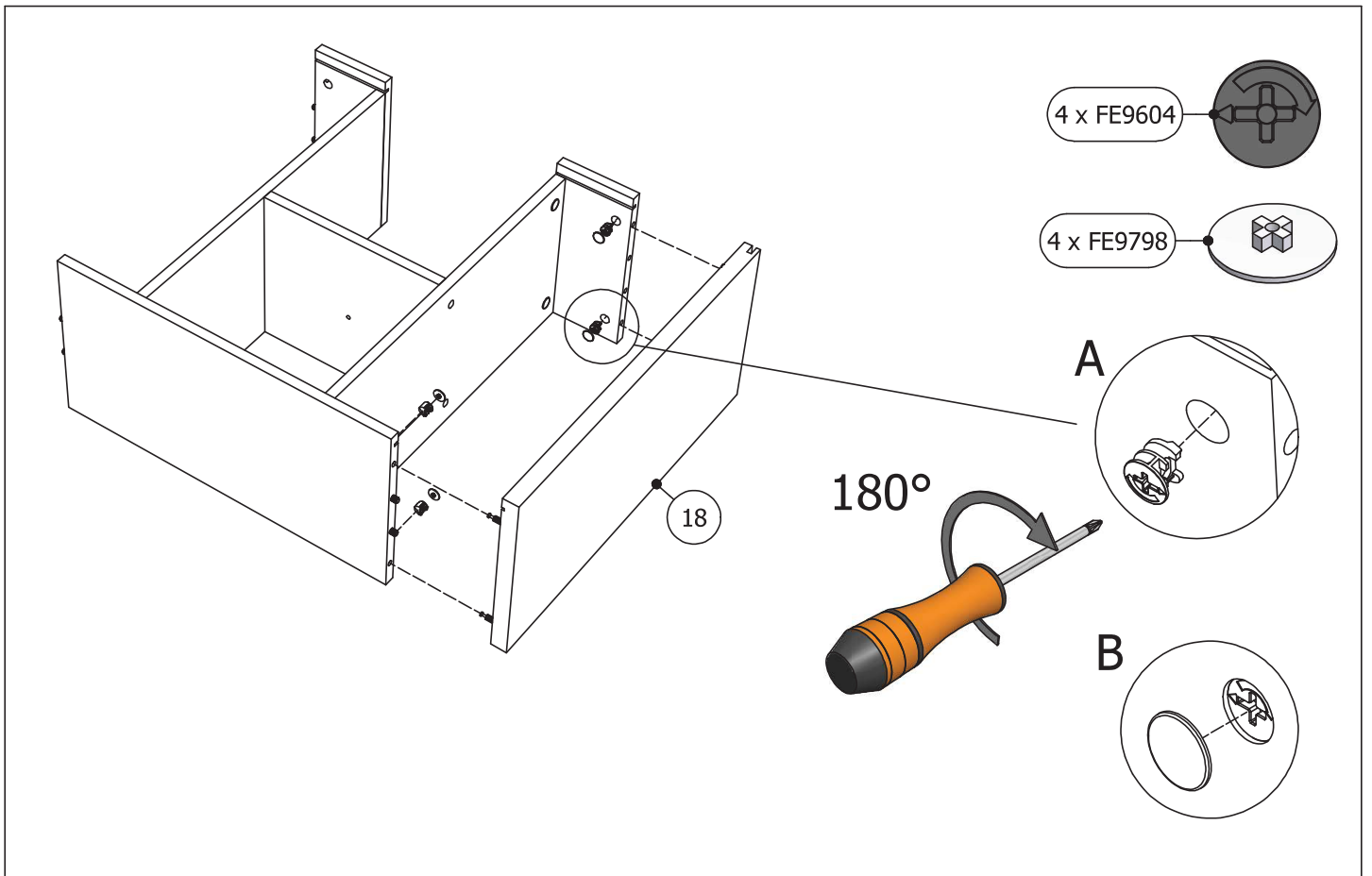

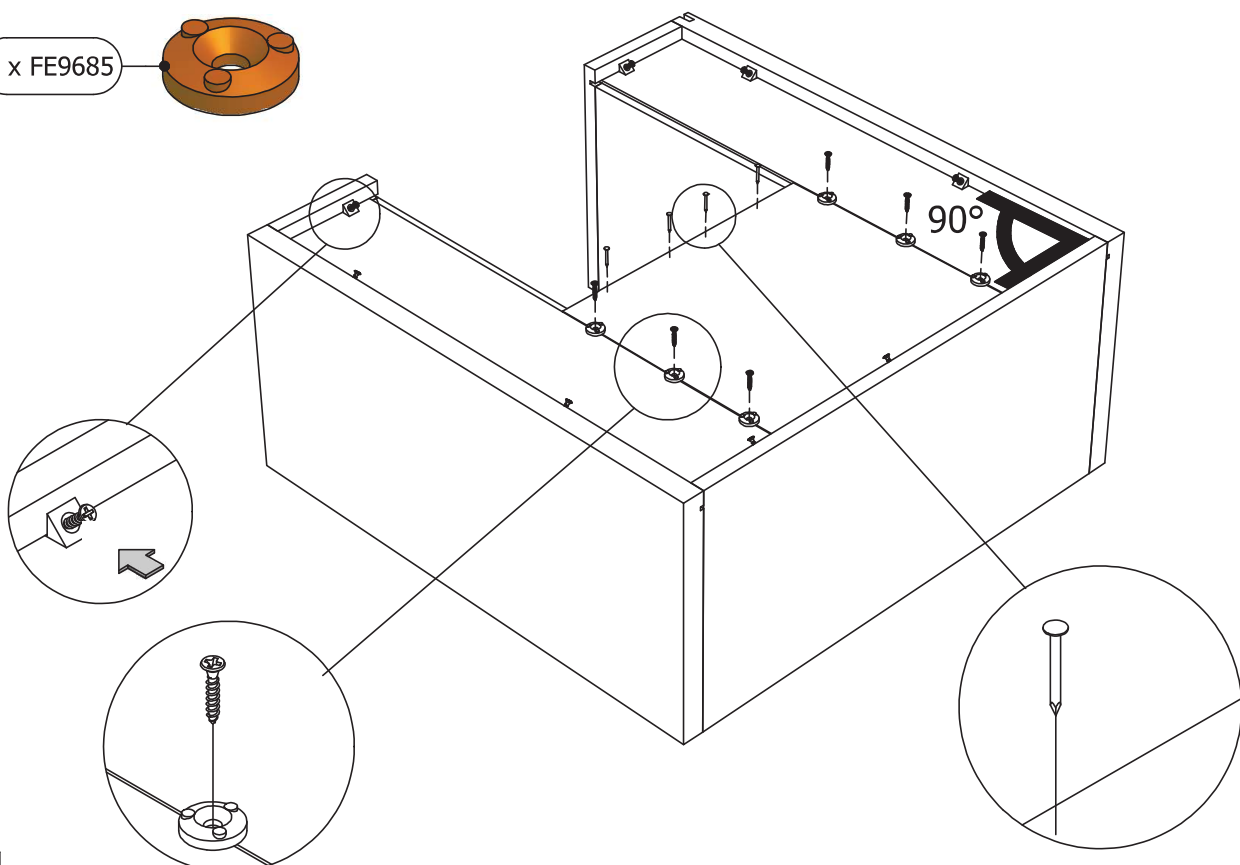
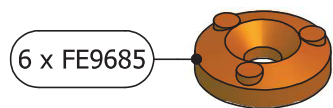
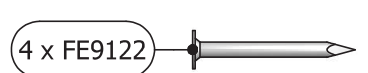
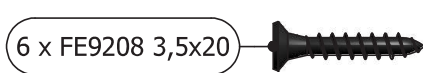
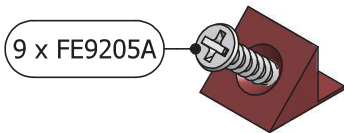
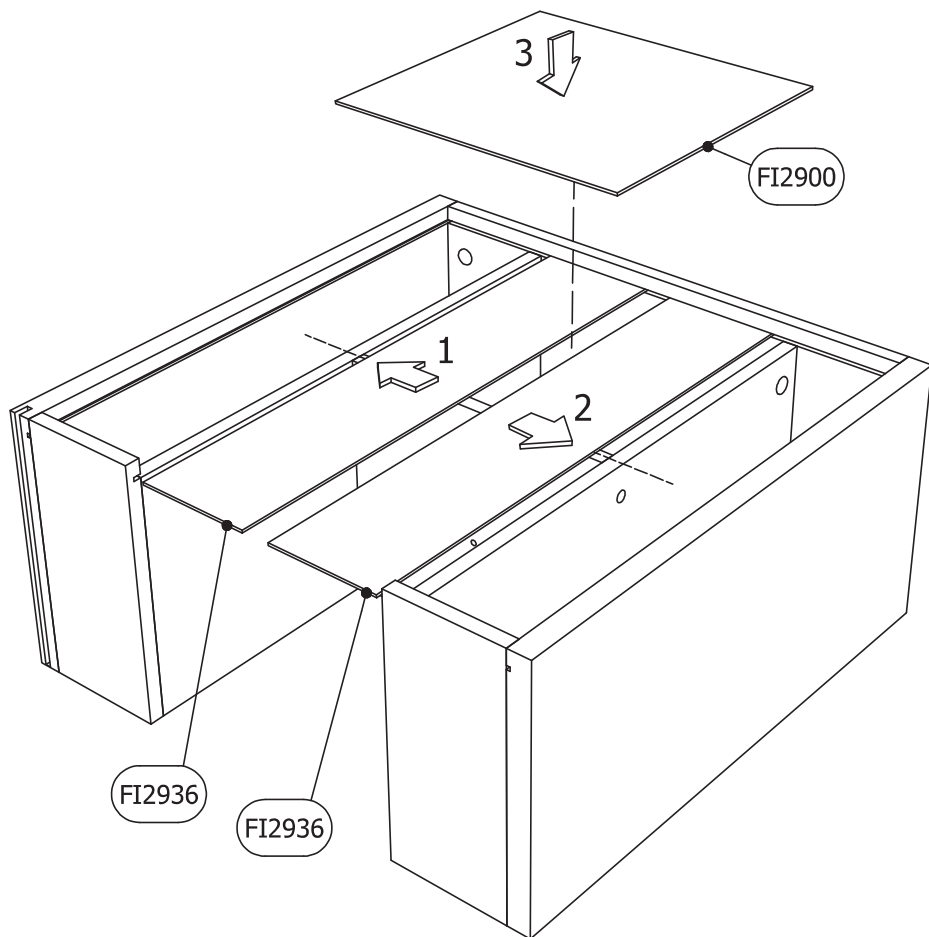

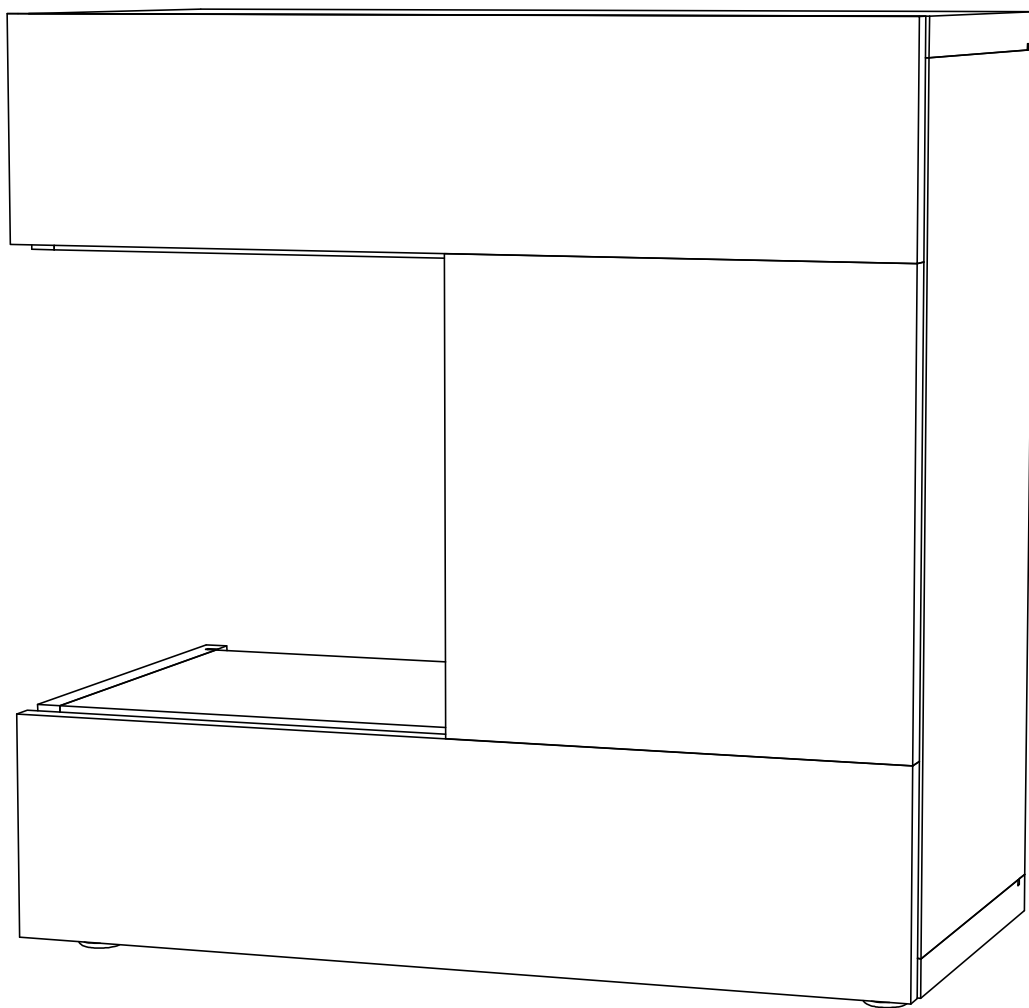

DE

Montageanleitung

FR

Notice de montage

NL

Handleiding voor de montage

CZ

Montážní návod

HU

Szerelési útmutató

TR

Montaj talimatı

PT

Instruções de montagem

AR

تعليمات التجميع

GB USA

Assembly instructions

I

Istruzione di montaggio

PL

Instrukcja montażu

SK

Návod na montáž

RO

Instrucțiuni de montaj

RU

Инструкция по монтажу

ES

Instrucciones de montaje

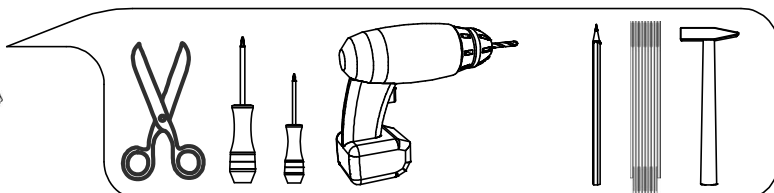
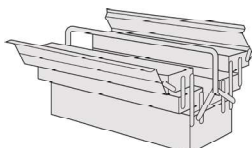
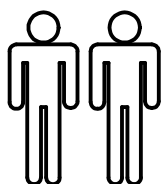

Service • Dienstverlening • Serwis • Servis • Сервисная служба • Servizio

Name • Naam • Nazwa • İsim • Название • Nom • Nome

Nr. • No. • Номер • Nu.

Тур • Туре • Тір • Тип • Тіро

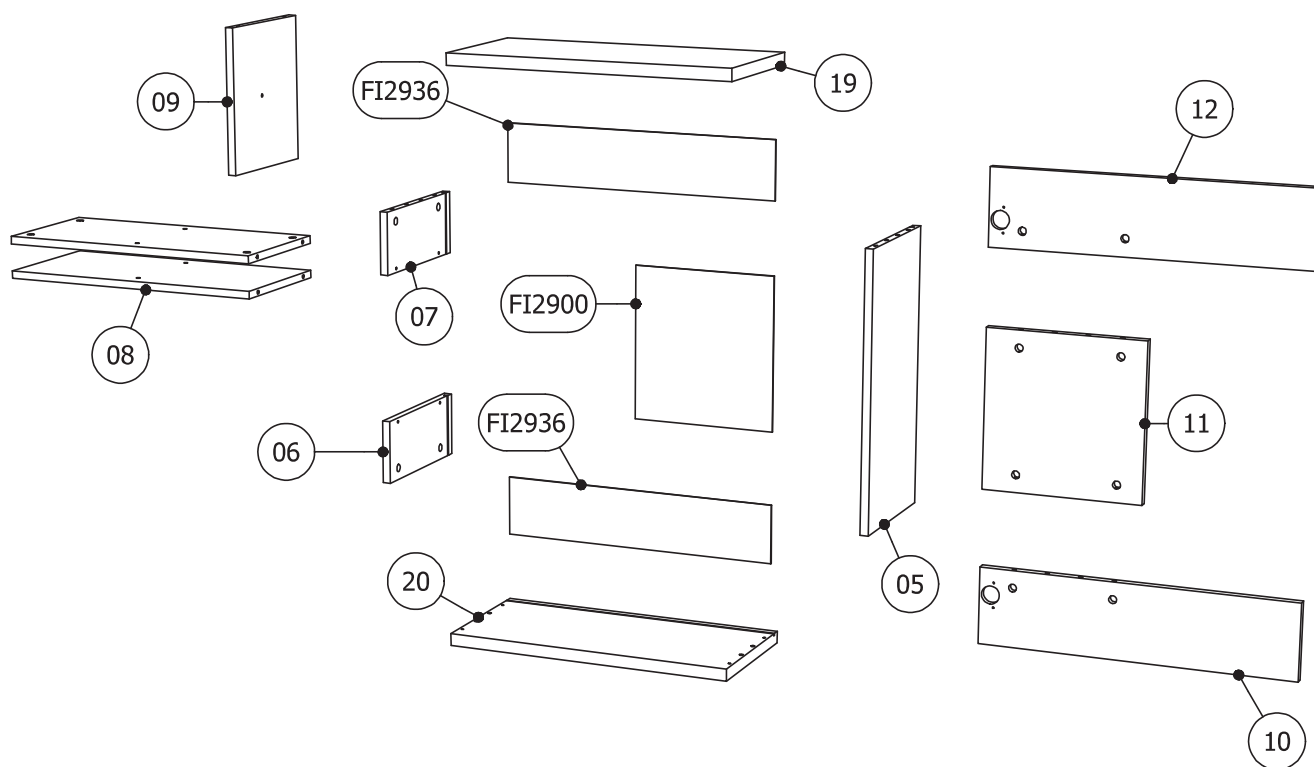
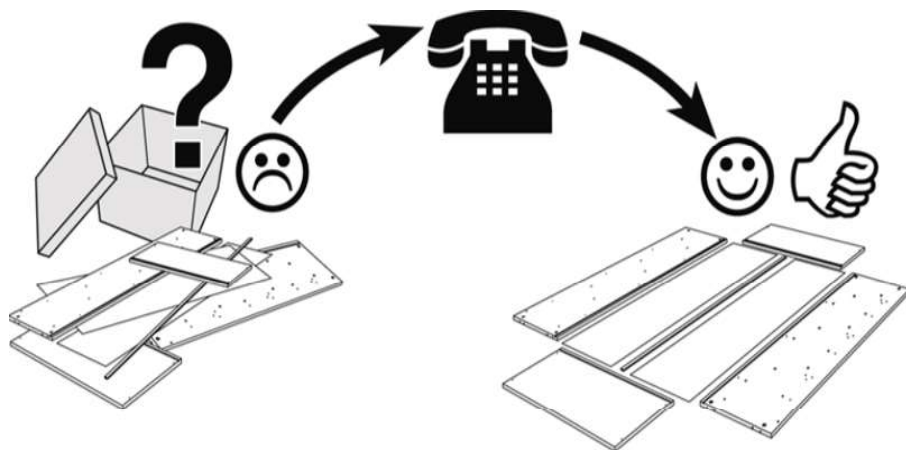

Code	Qt.	Dimensions	Box	Code	Qt.	Dimensions	Box
05	1	556x282x16	2-1	11	1	308x305x16	2-2
06	1	128x282x16	2-1	12	1	149x605x16	2-2
07	1	128x282x16	2-1	19	1	600x282x25	2-1
08	2	568x262x16	2-1	20	1	600x282x25	2-1
09	1	300x262x16	2-1	FI2900	1	318x298x3	2-2
10	1	149x605x16	2-2	FI2936	2	122x582x3	2-2

13

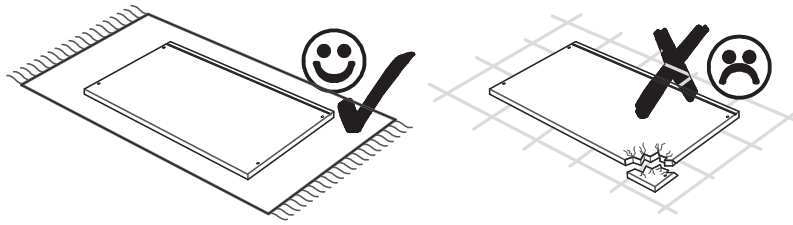

6 x SPL001

8 x FE2429

4 x FE9718

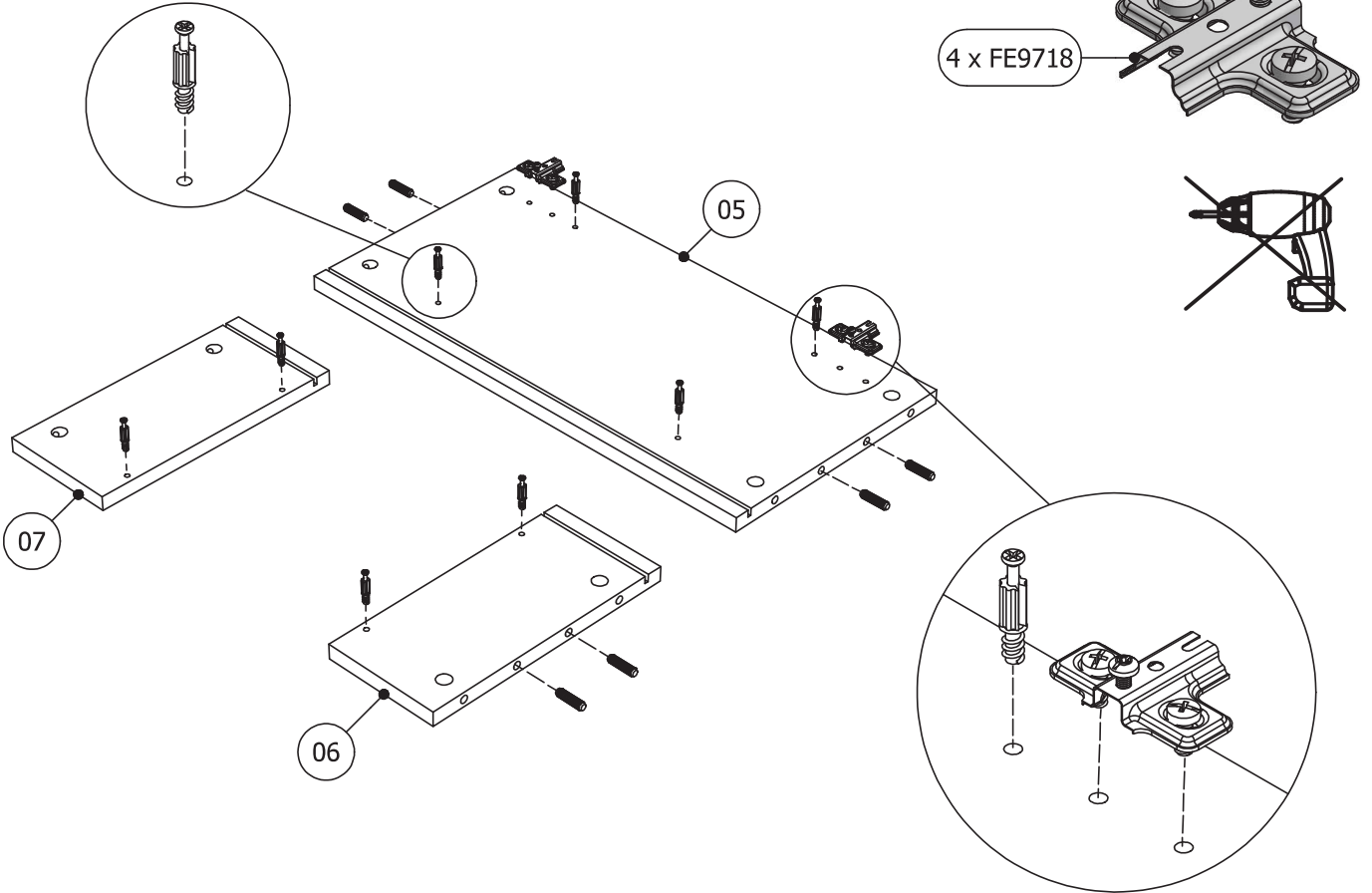

4 x FE9134 7x50

4 x FE9013

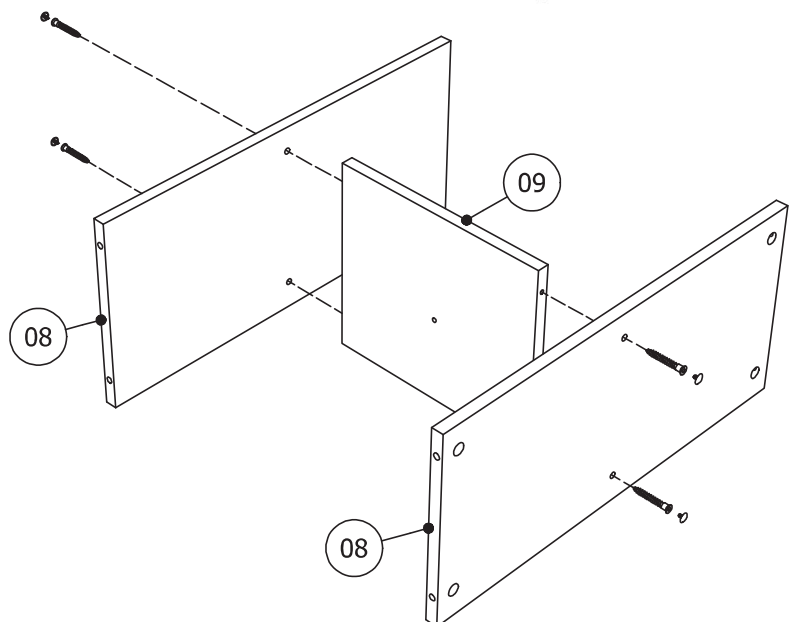

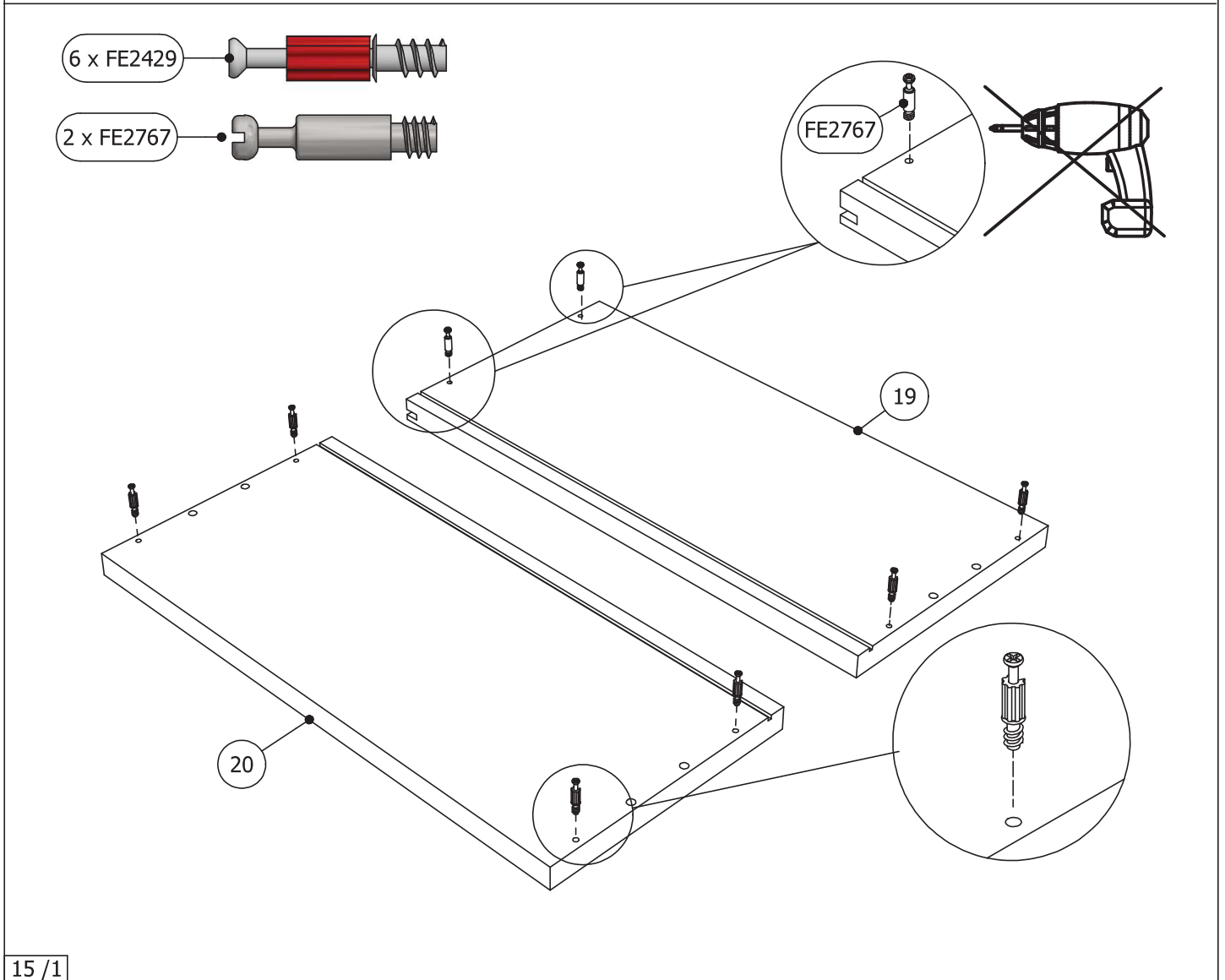
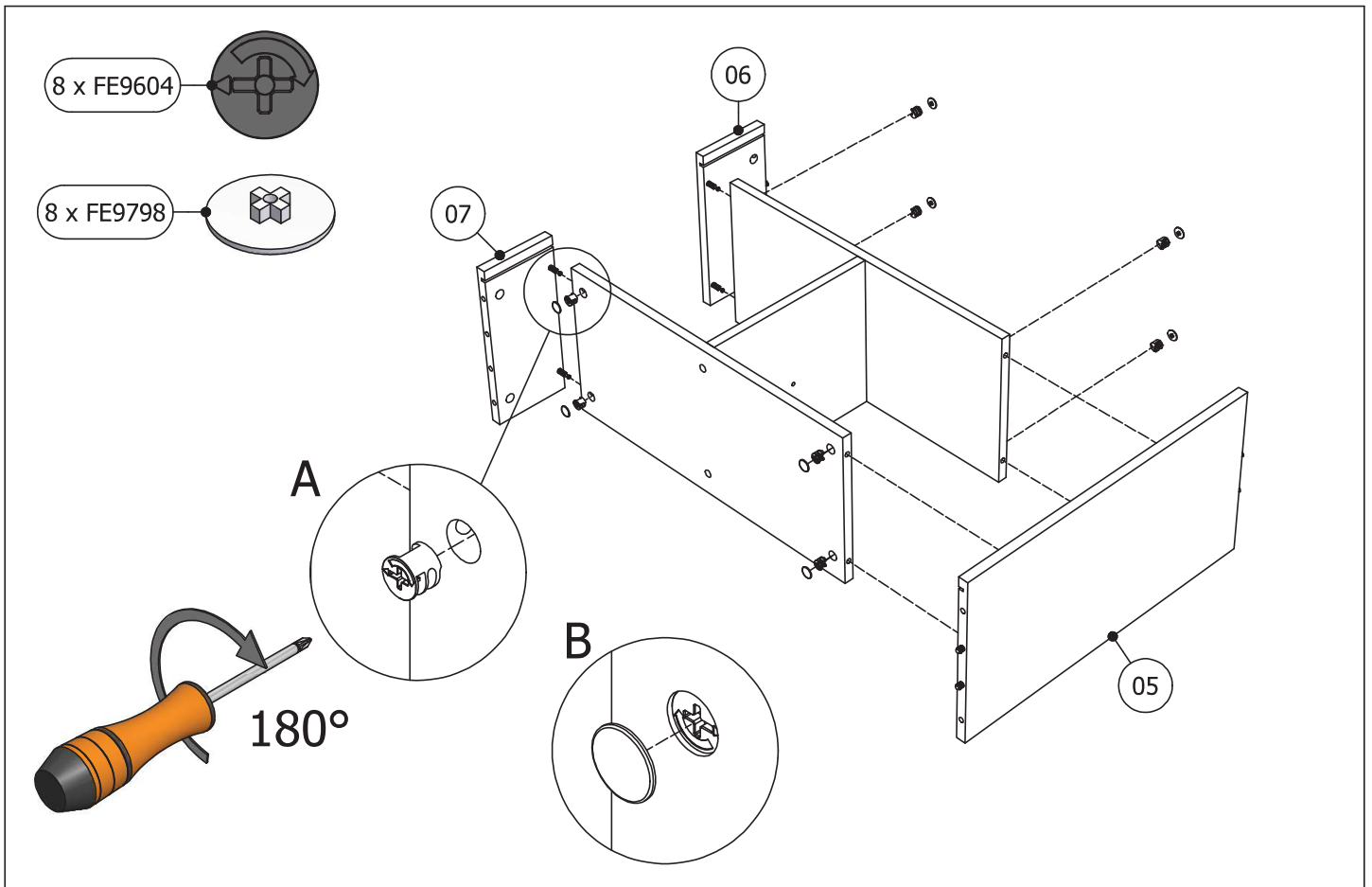

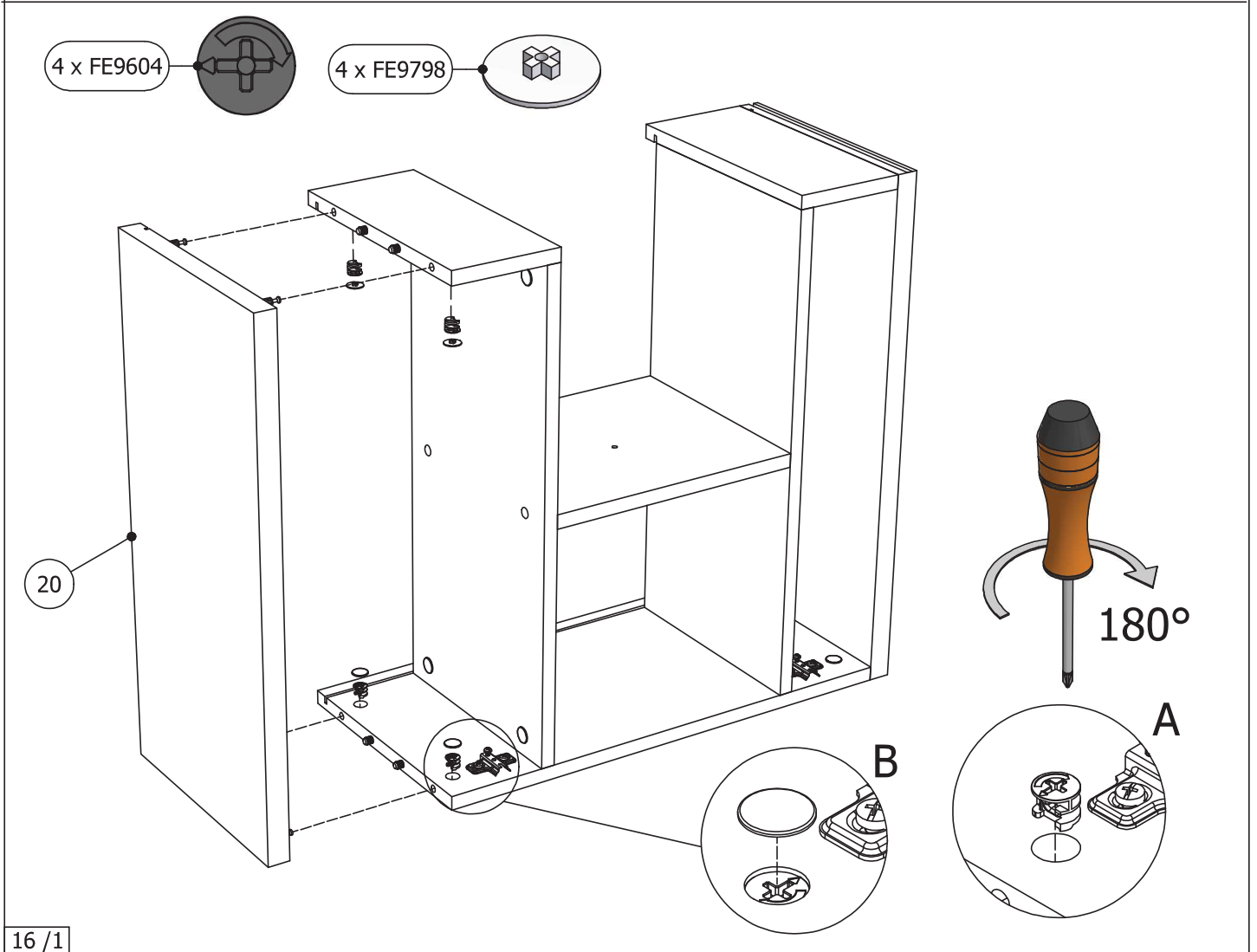
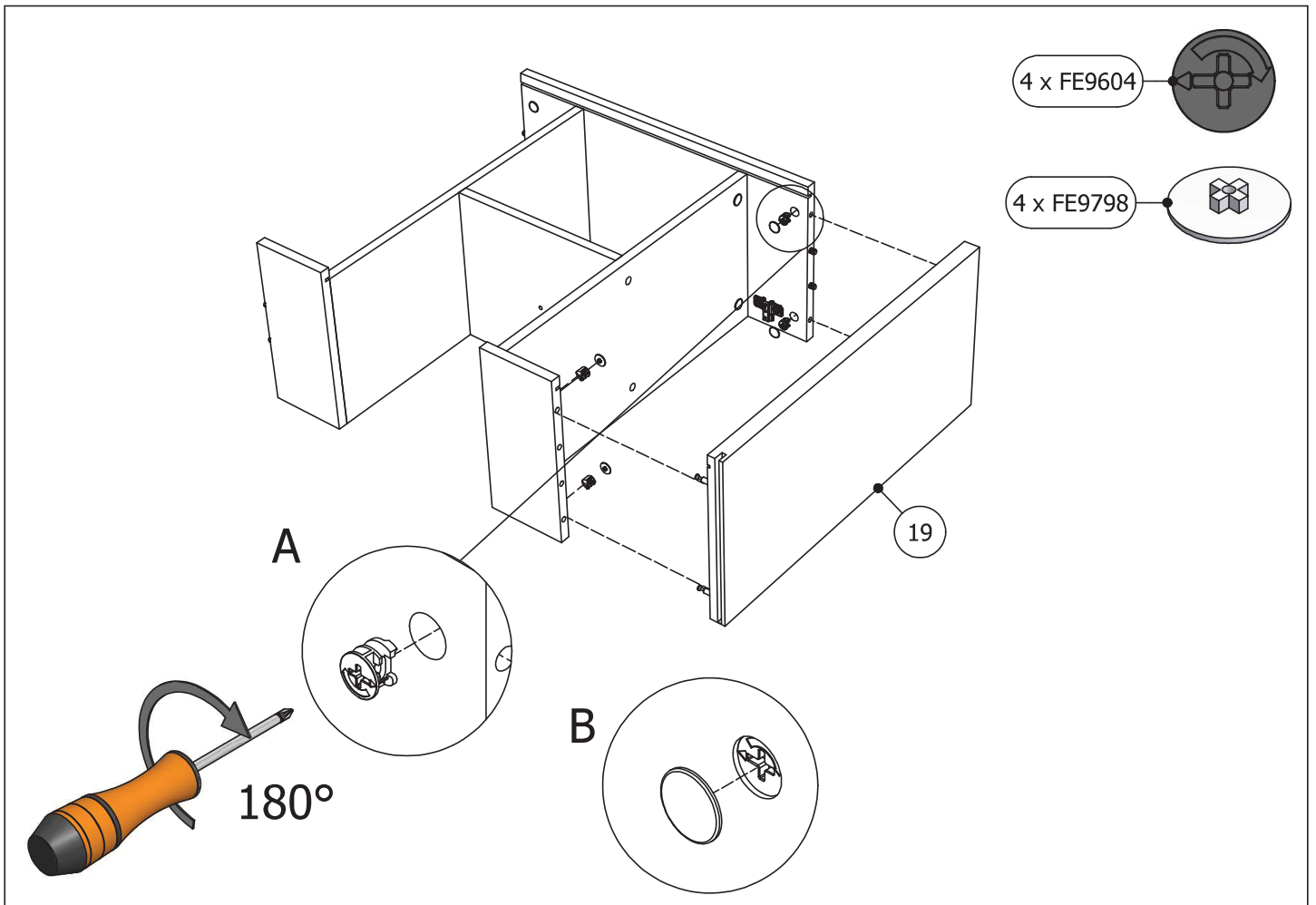

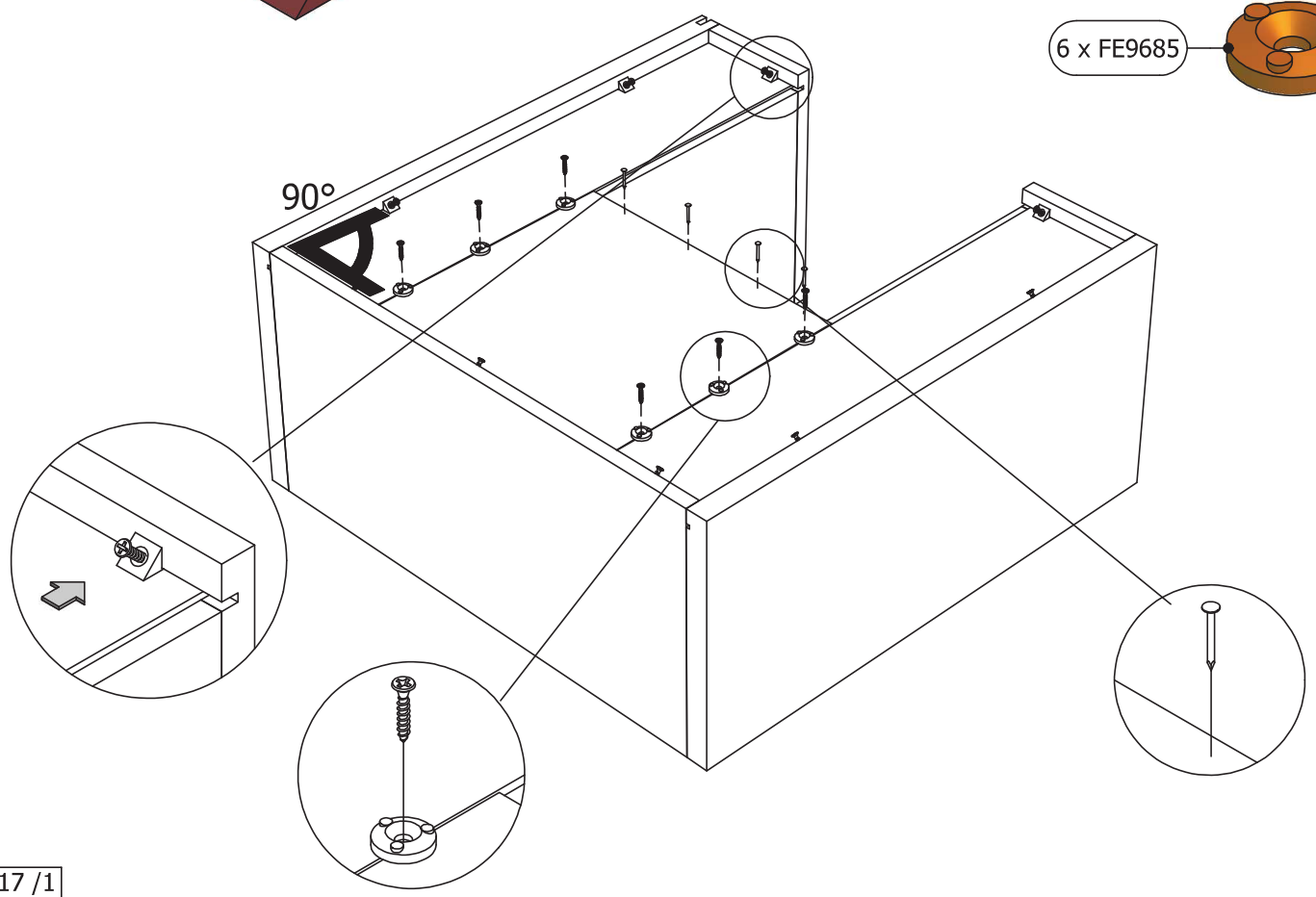
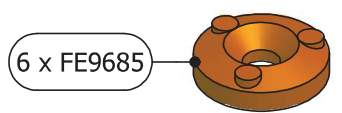
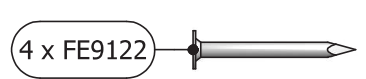
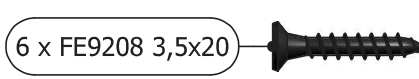
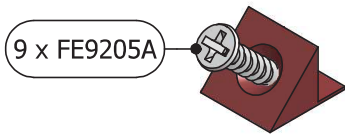
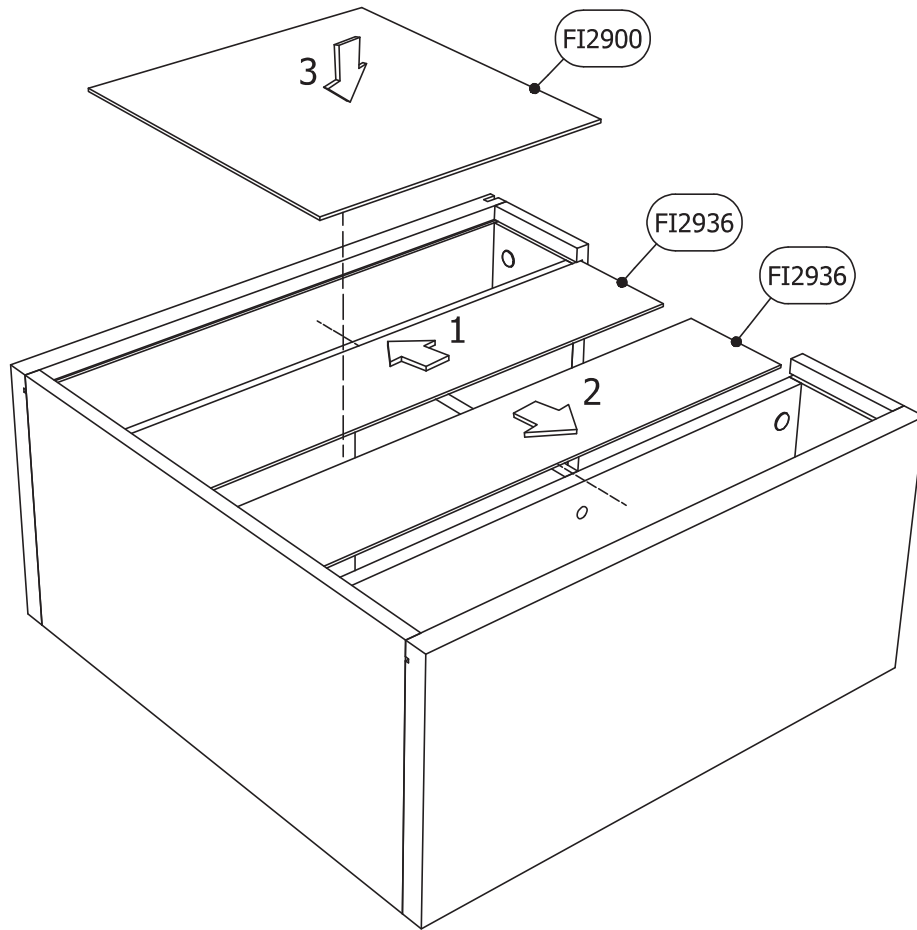

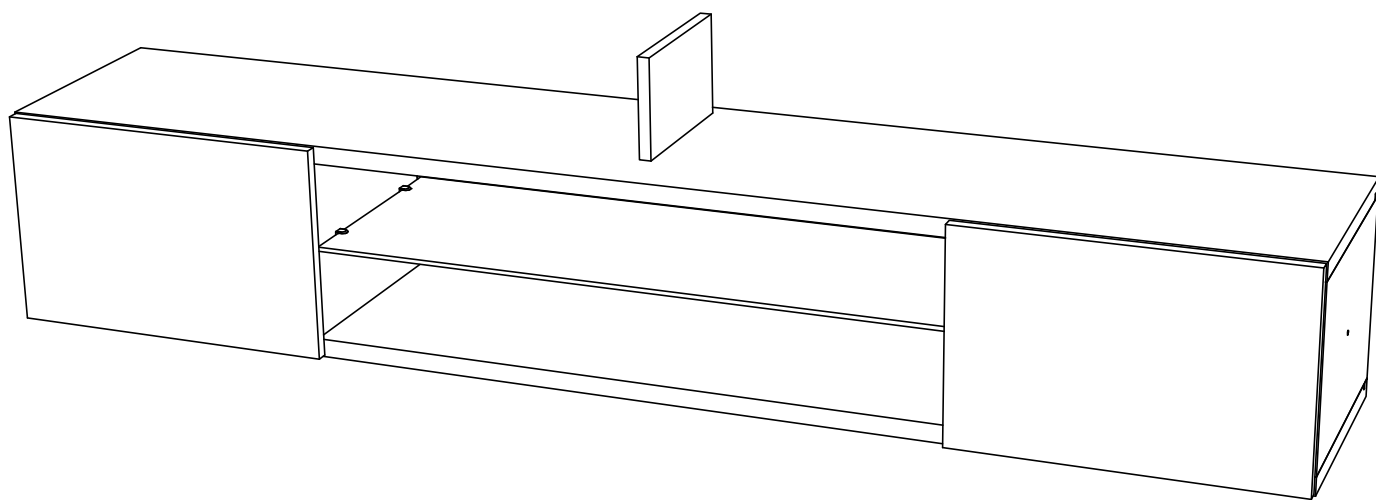

DE

Montageanleitung

FR

Notice de montage

NL

Handleiding voor de montage

CZ

Montážní návod

HU

Szerelési útmutató

TR

Montaj talimatı

PT

Instruções de montagem

AR

تعليمات التجميع

GB USA

Assembly instructions

I

Istruzione di montaggio

PL

Instrukcja montażu

SK

Návod na montáž

RO

Instrucțiuni de montaj

RU

Инструкция по монтажу

ES

Instrucciones de montaje

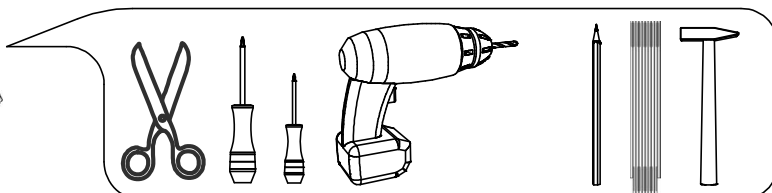
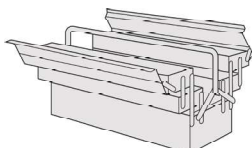
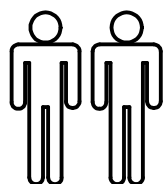

Service • Dienstverlening • Serwis • Servis • Сервисная служба • Servizio

Name • Naam • Nazwa • İsim • Название • Nom • Nome

Nr. • No. • Номер • Nu.

Тур • Туре • Тір • Тип • Тіро

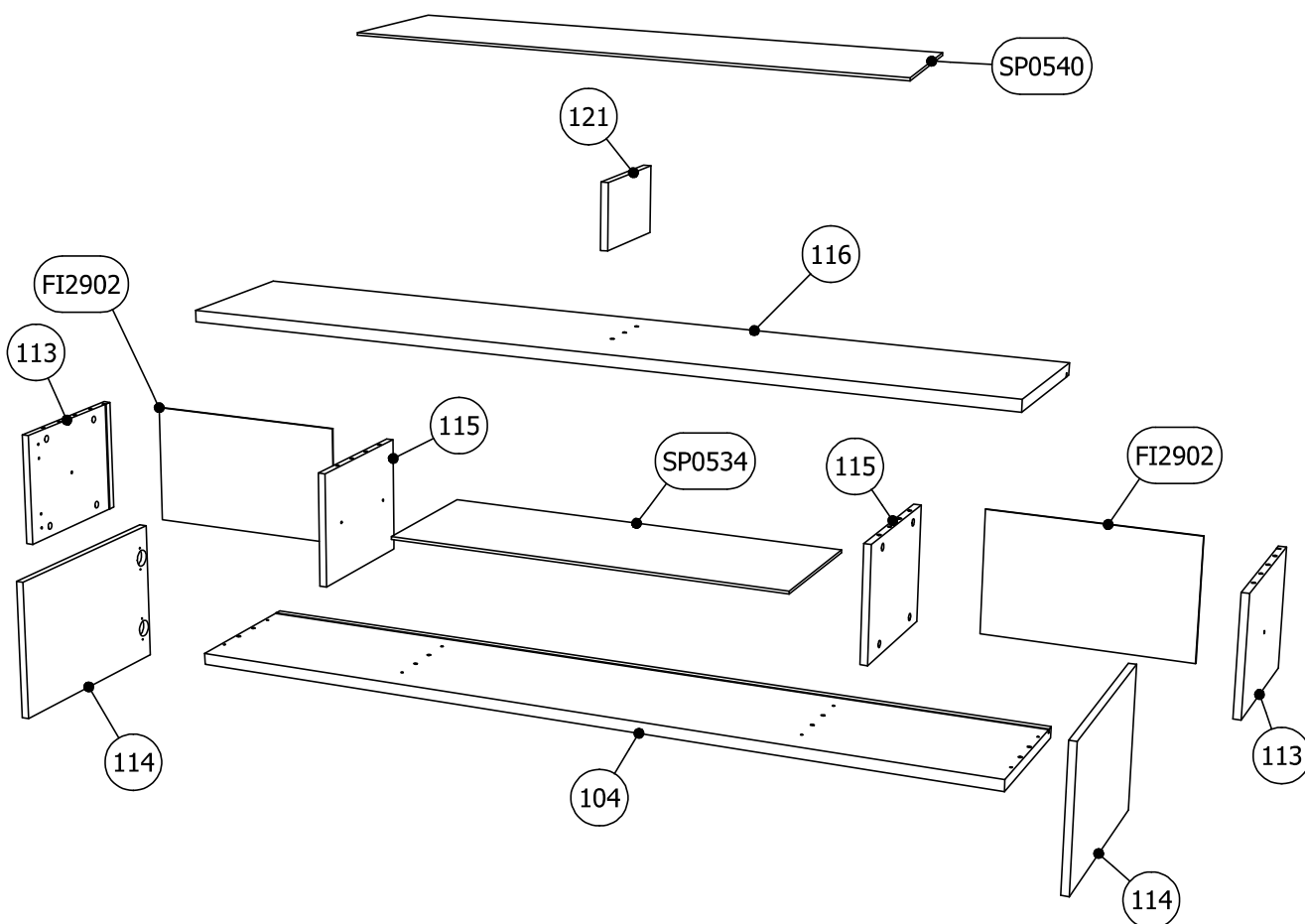
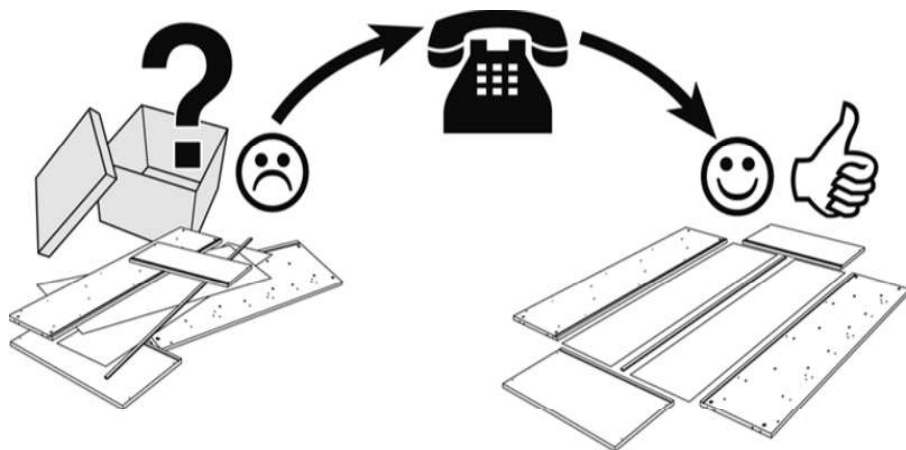

Code	Qt.	Dimensions	Box
104	1	1800x332x25	2-2
113	2	249x332x16	2-2
114	2	460x295x16	2-2
115	1	249x312x16	2-1
115	1	249x312x16	2-2
116	1	1800x332x25	2-2
121	1	139x220x16	2-1
FI2902	2	444x264x3	2-2
SP0534	1	885x312x6	2-2
SP0540	1	1243x281x6	2-2

13

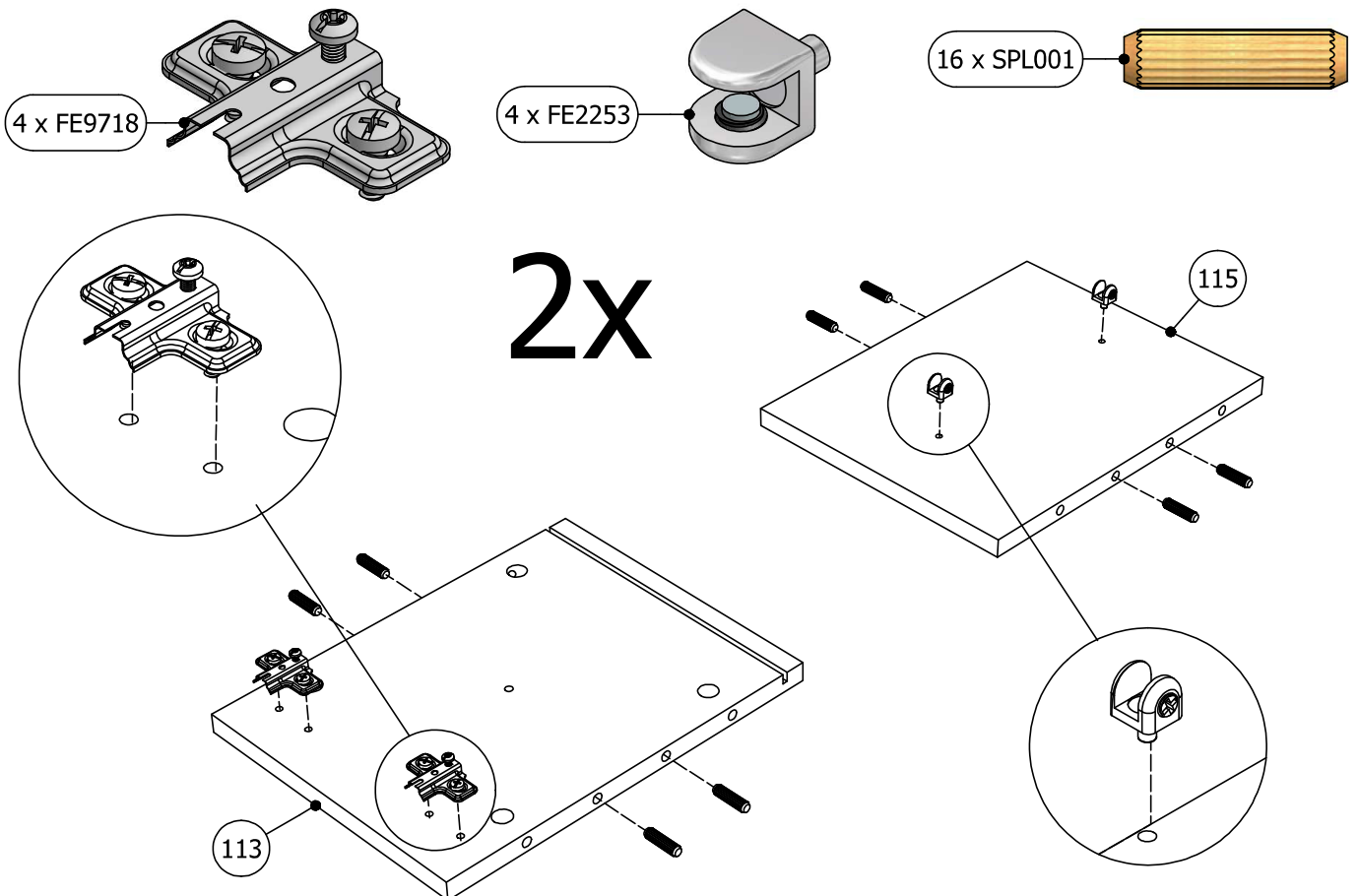
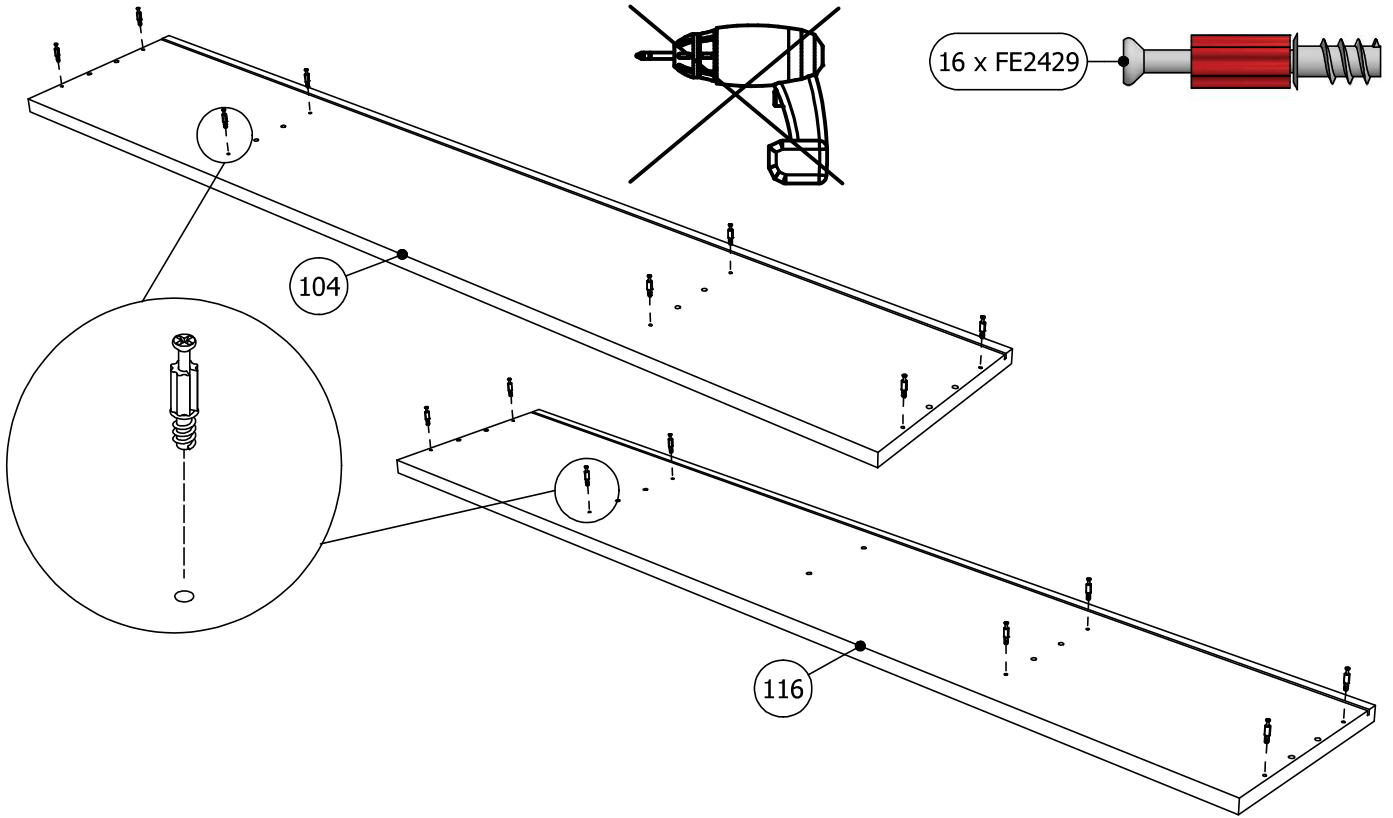
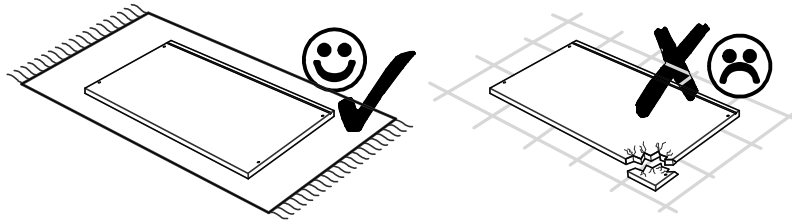

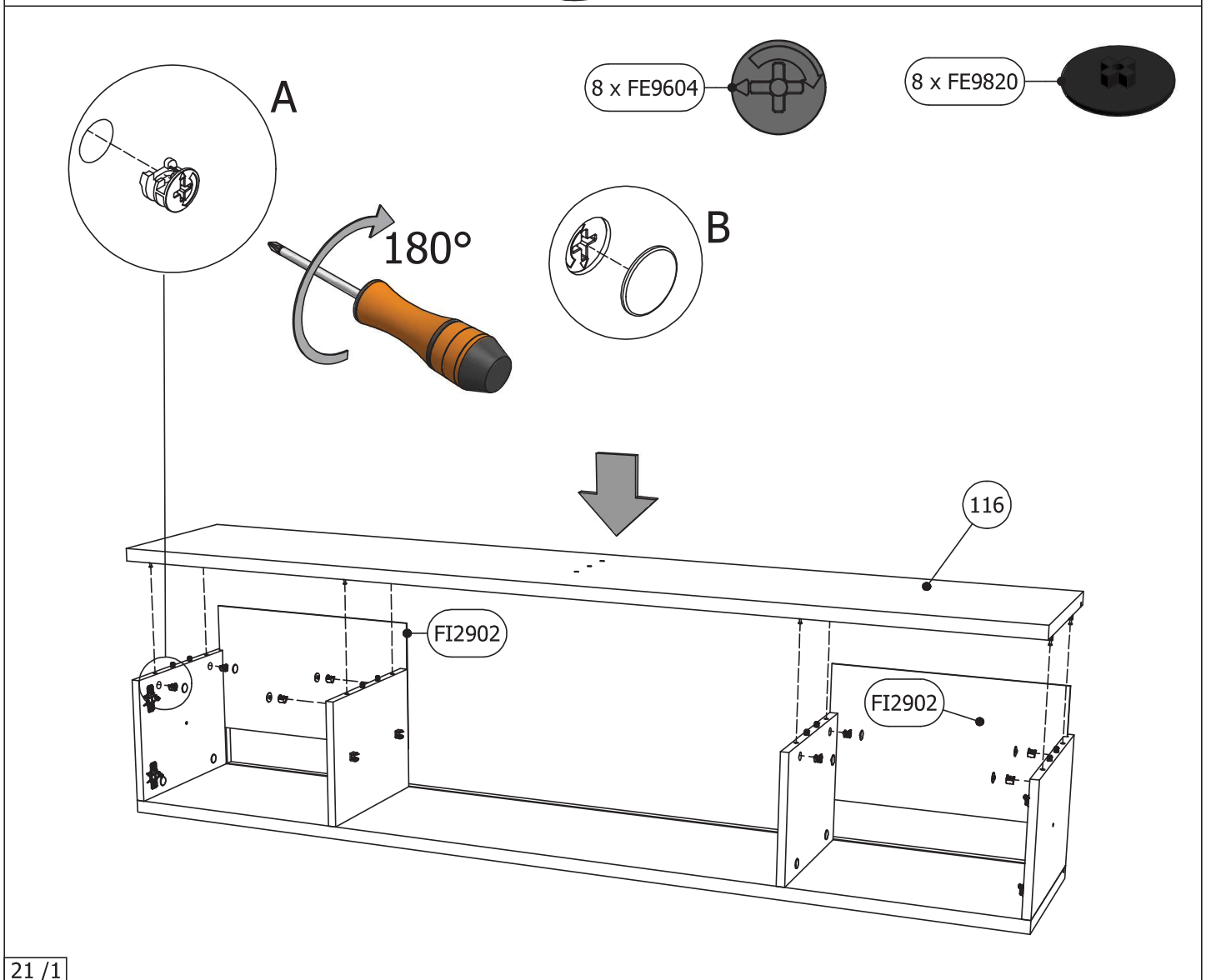
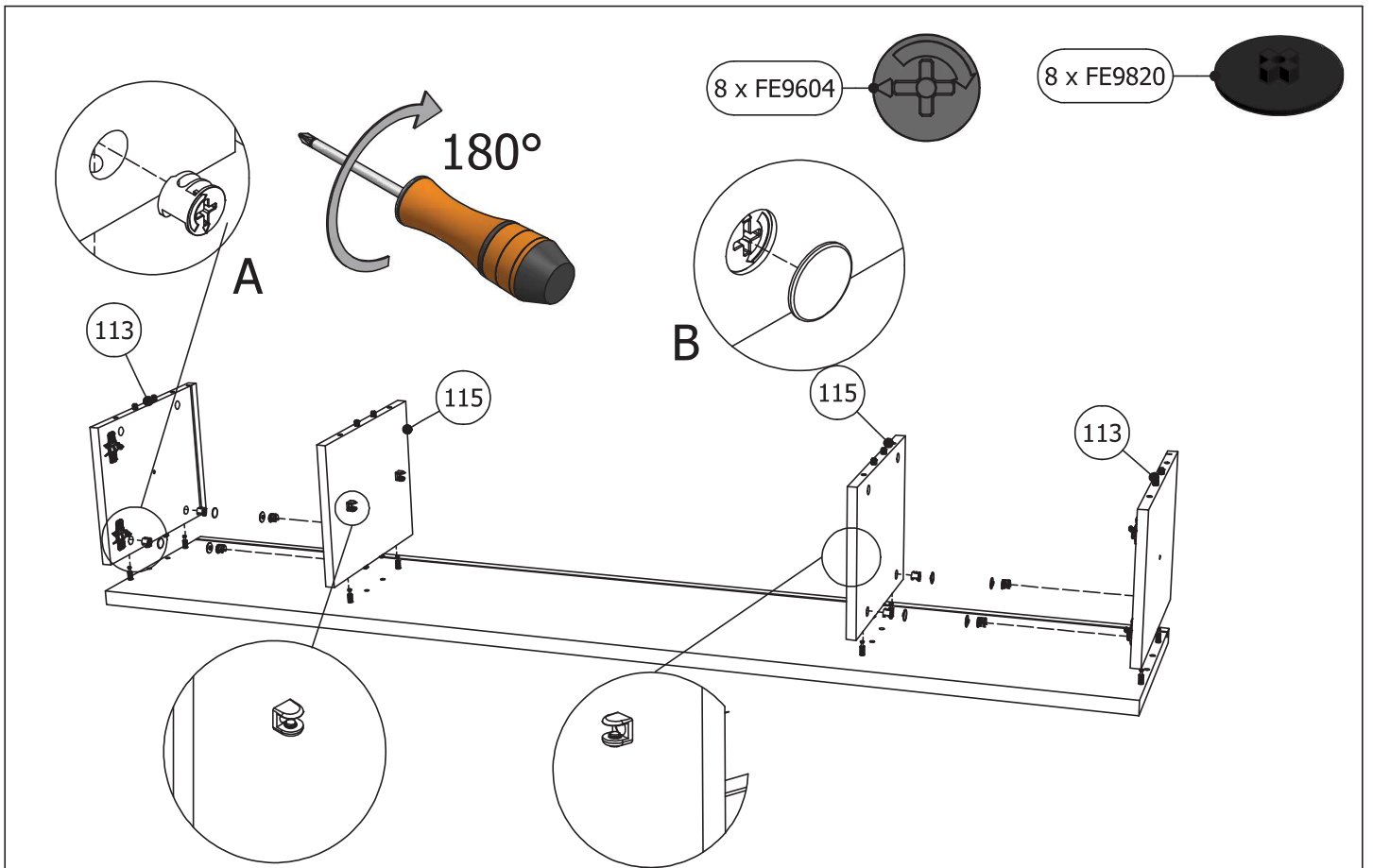

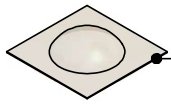

2 x FE2515A

1 x SPL001

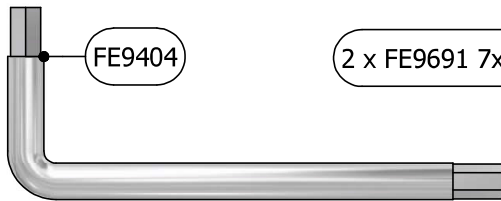
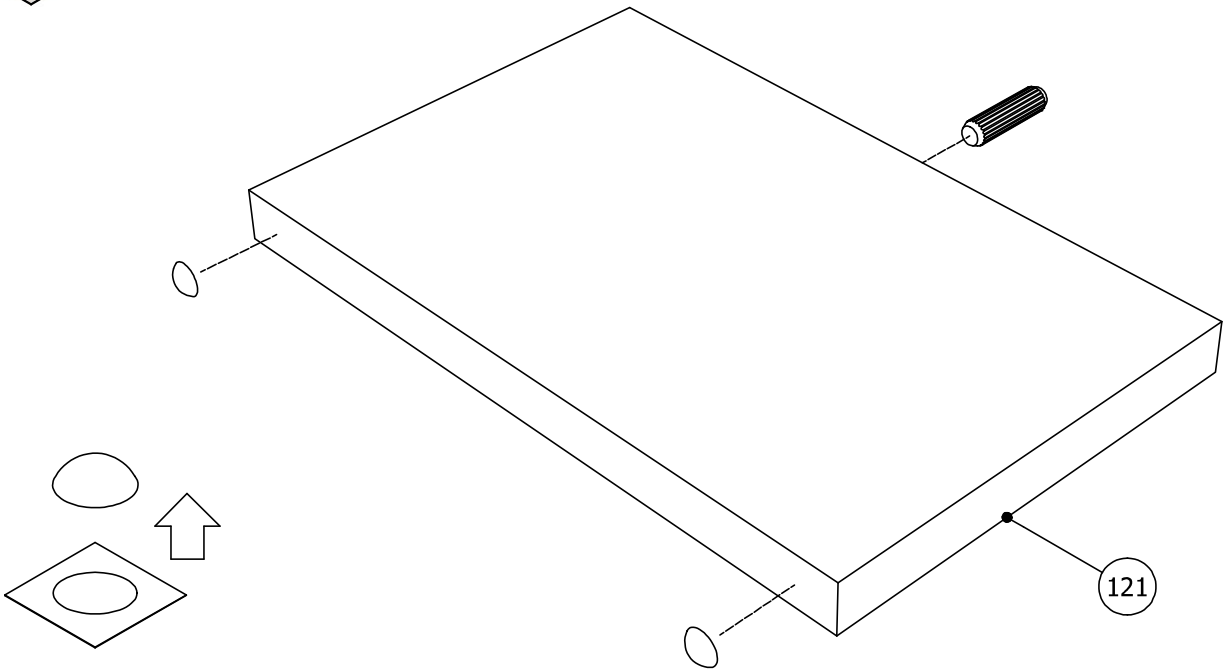

FE9404

2 x FE9691 7x60

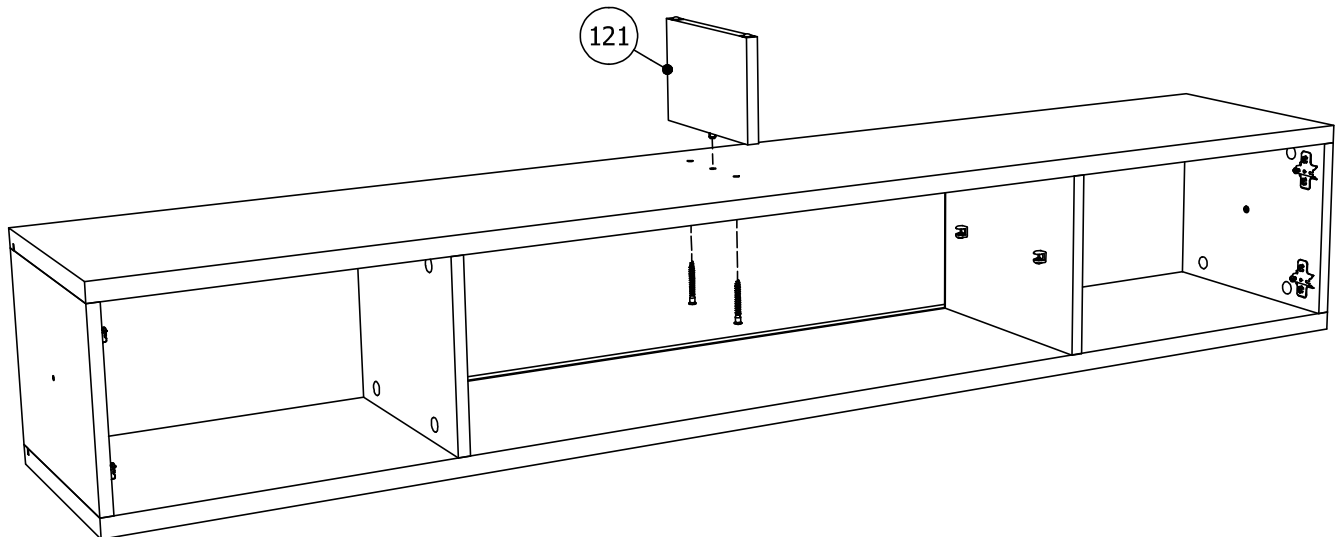

8 x FE9205A



8 x FE9122

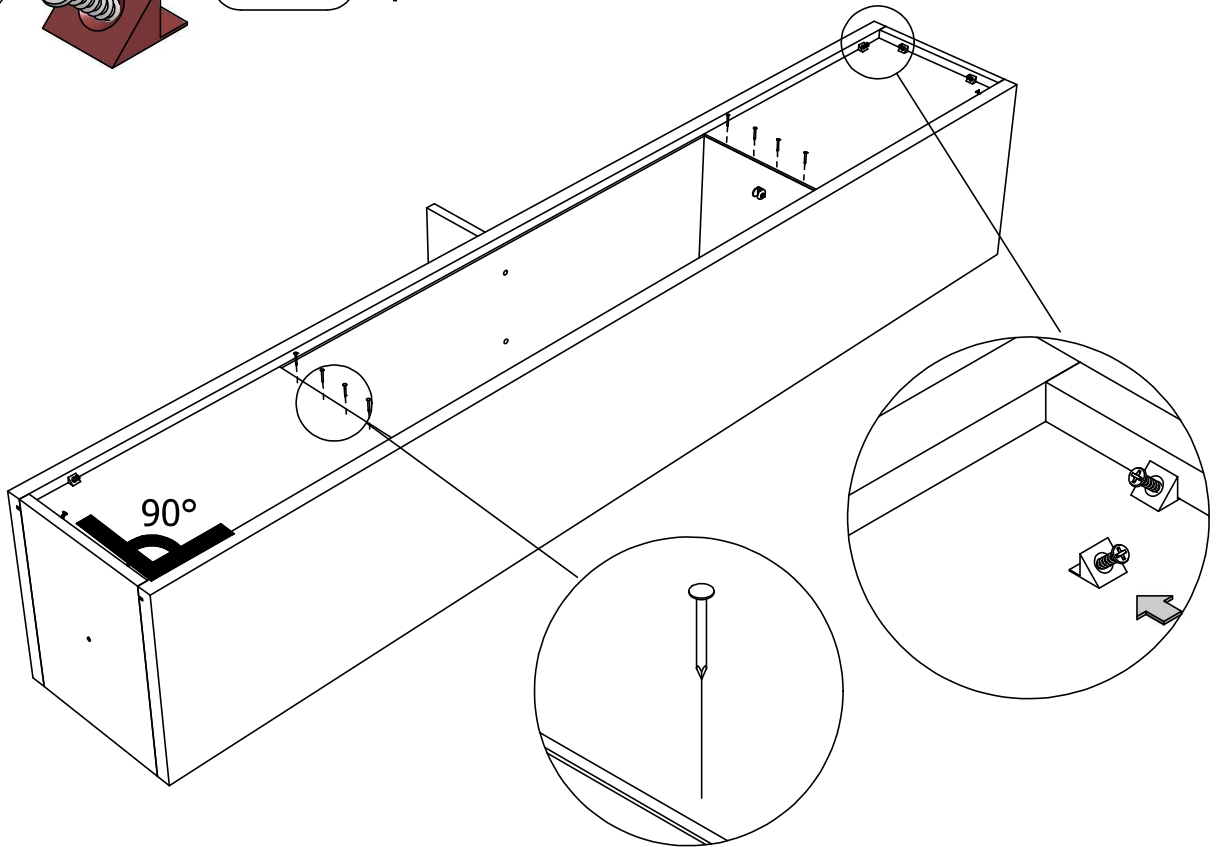

90°

8 x FE9403 3,5x16

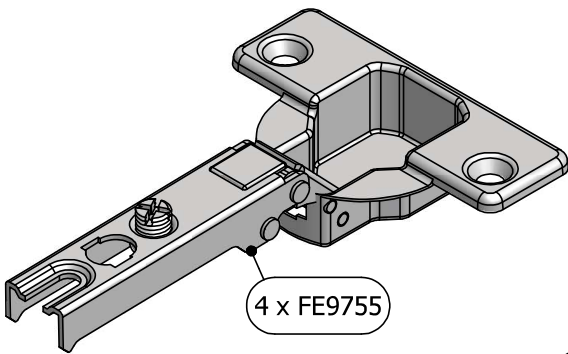

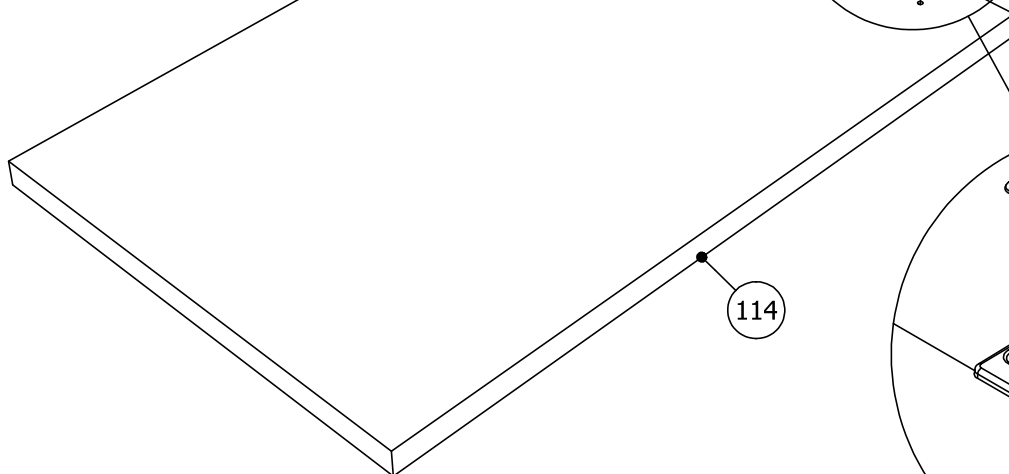
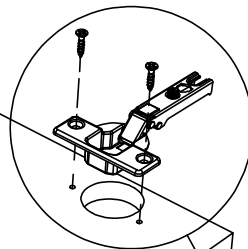
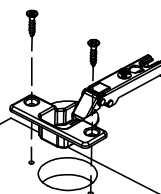

4 x FE9755

2x

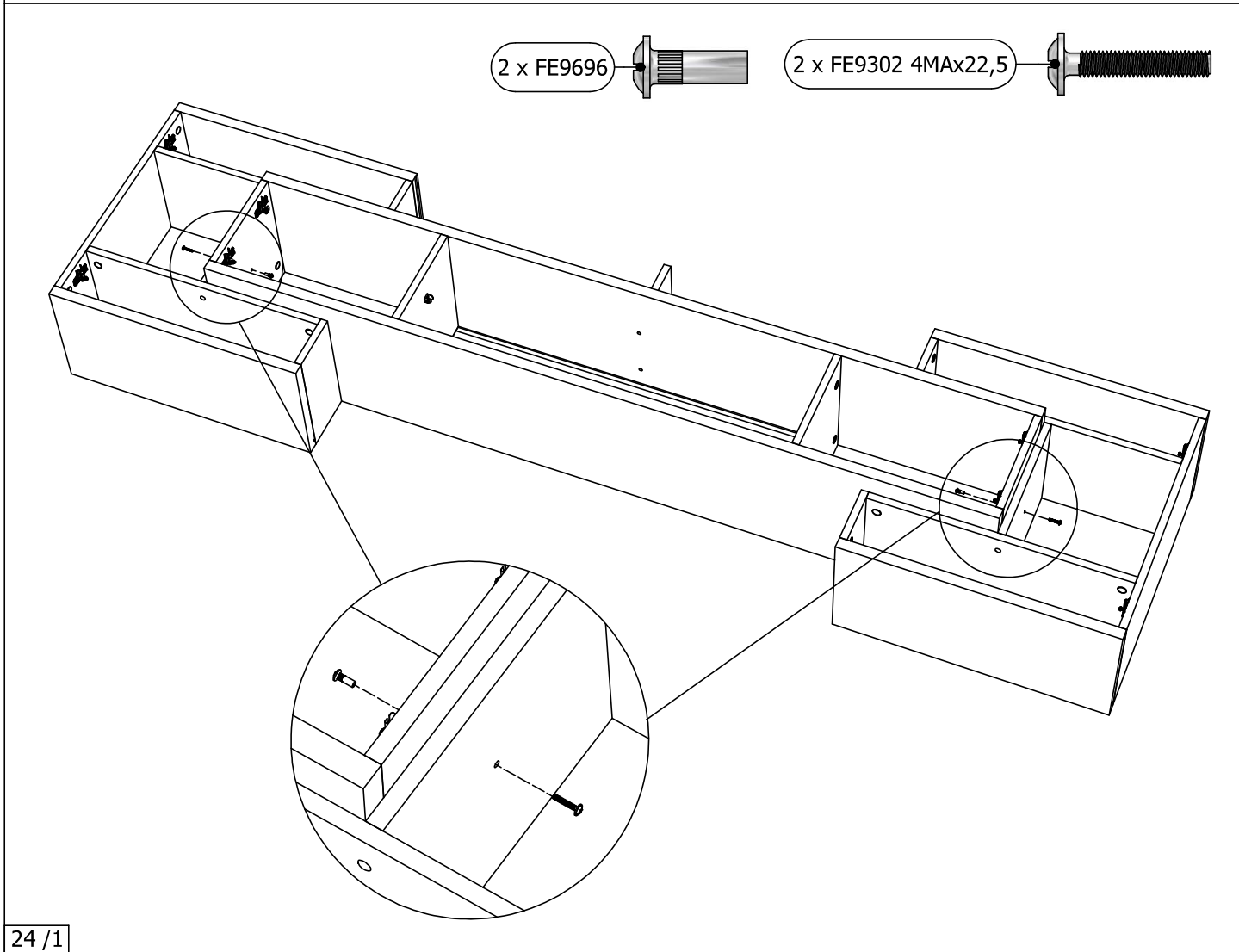
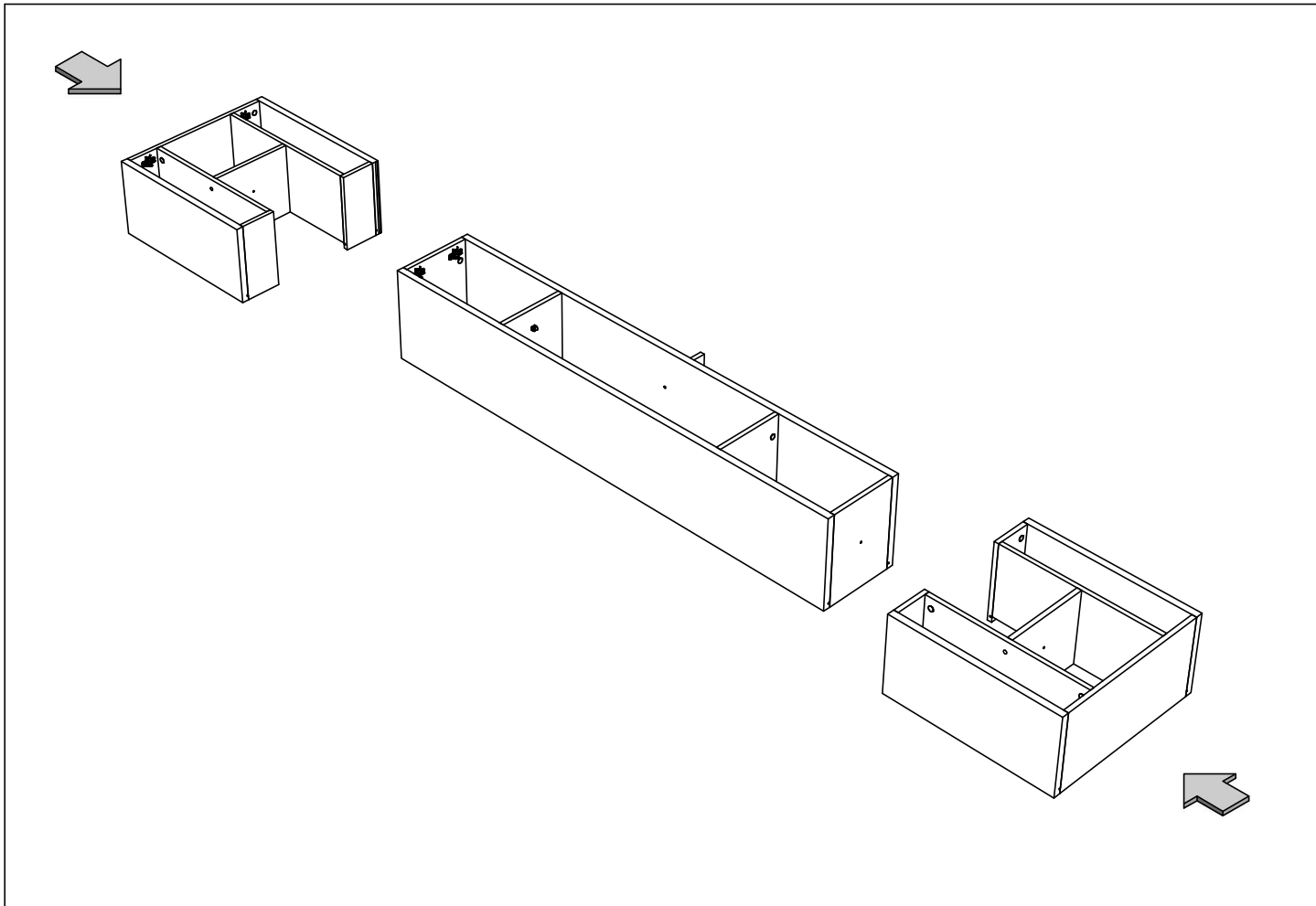

114



8 x FE9728 3x25 

8 x FE9729 

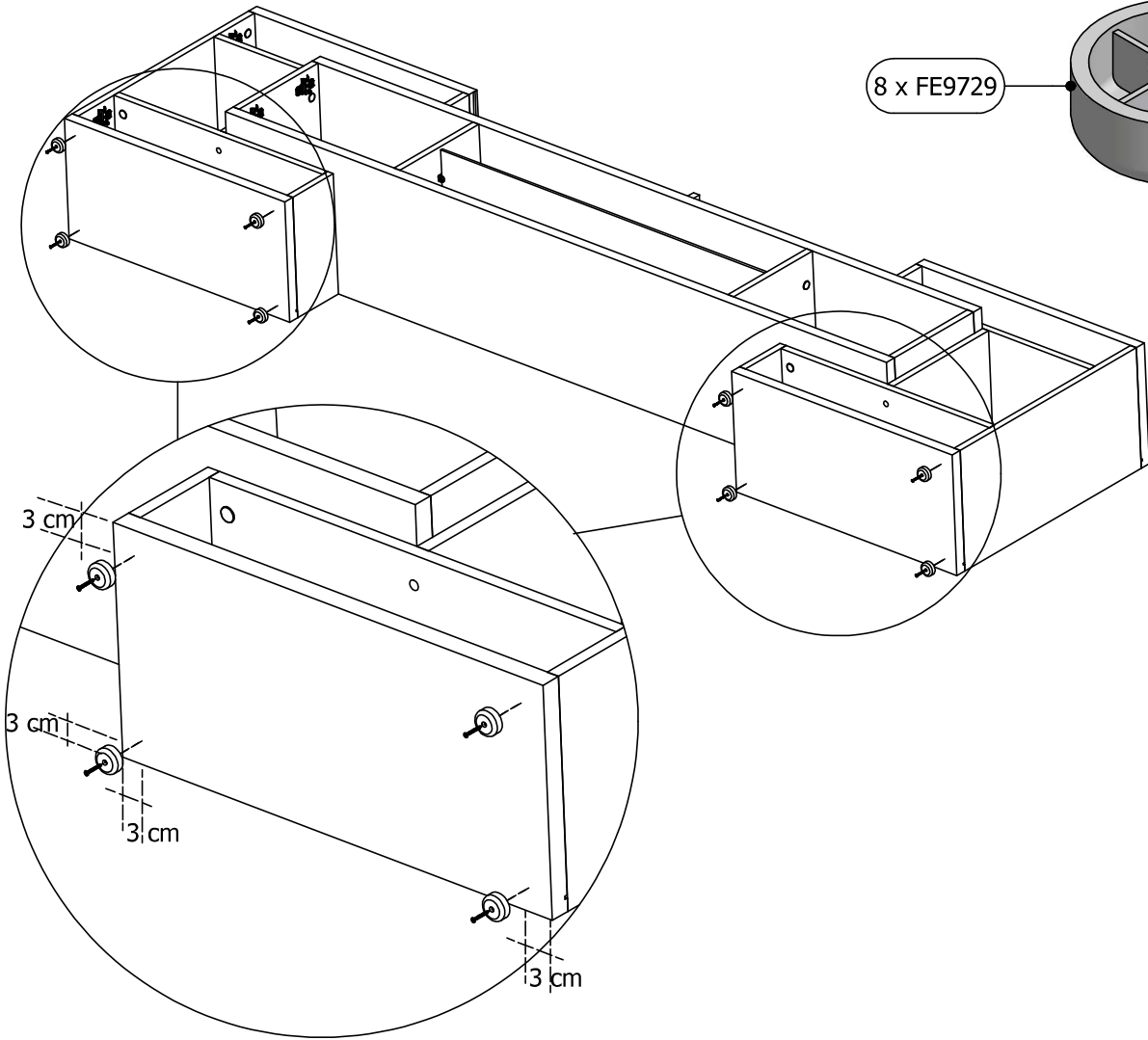

8 x FE2279 

2x

8 x FE9604 

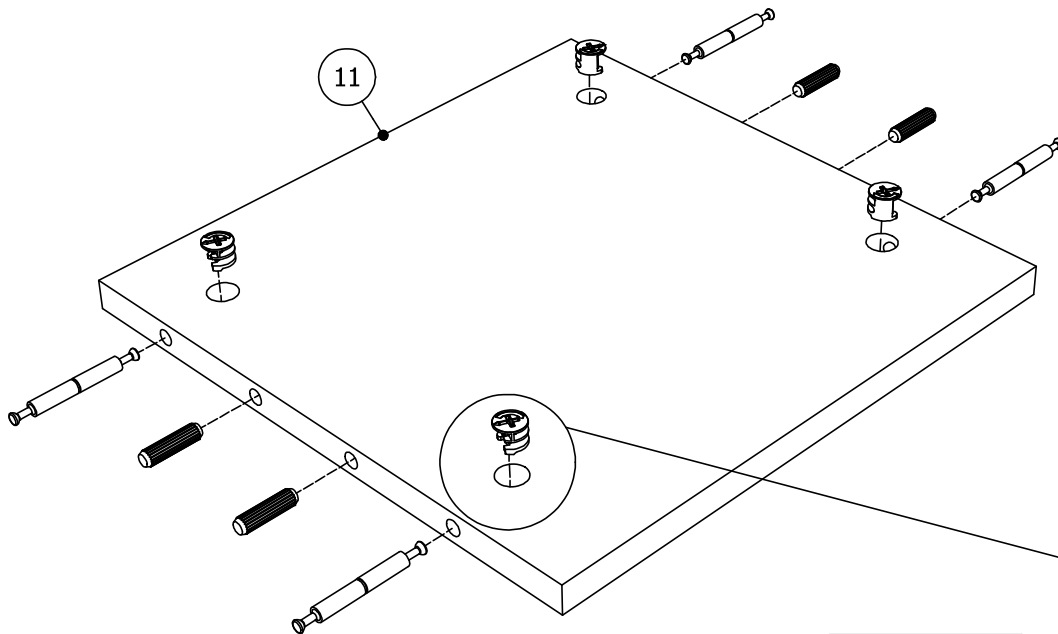

180°

8 x SPL001 

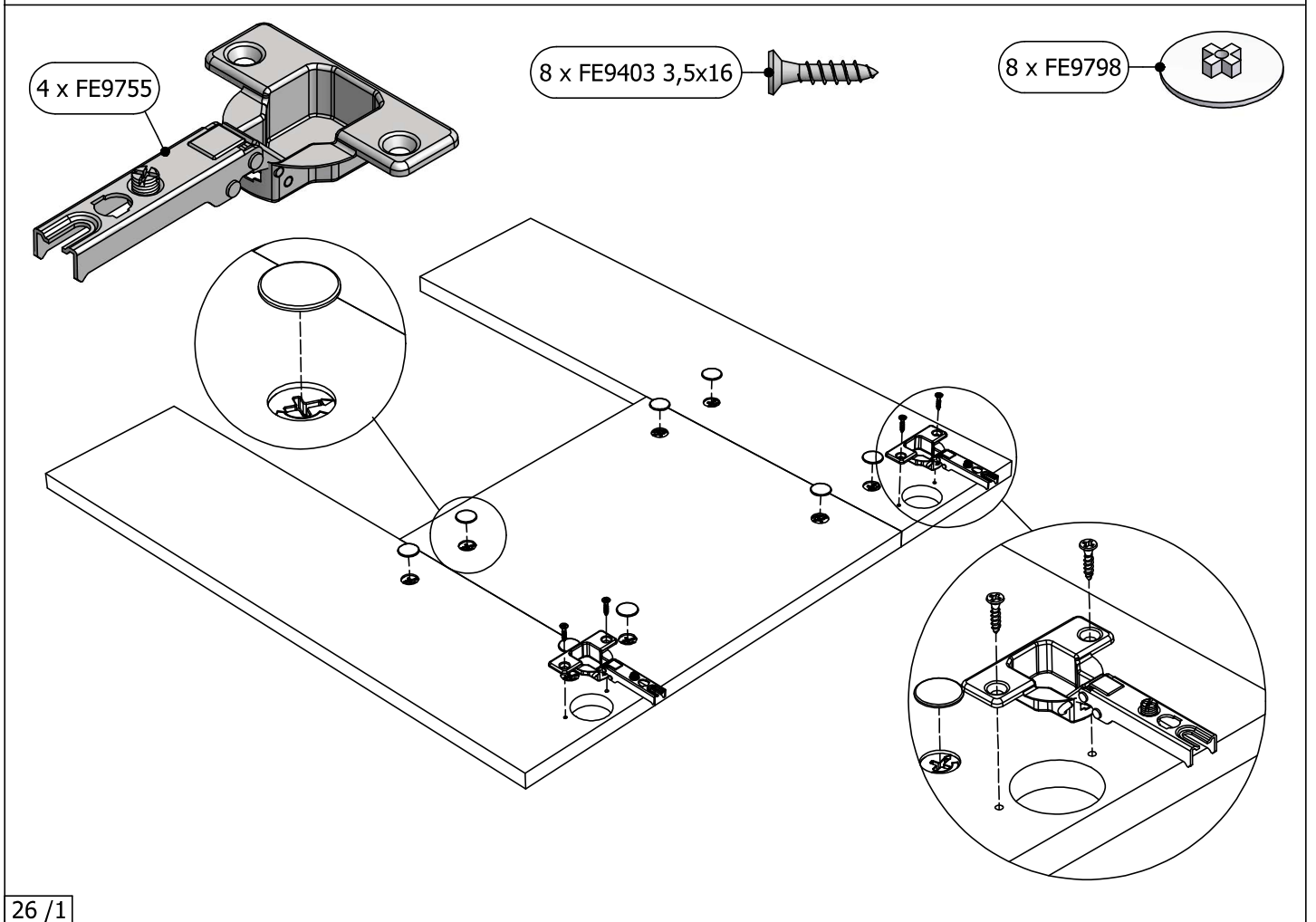
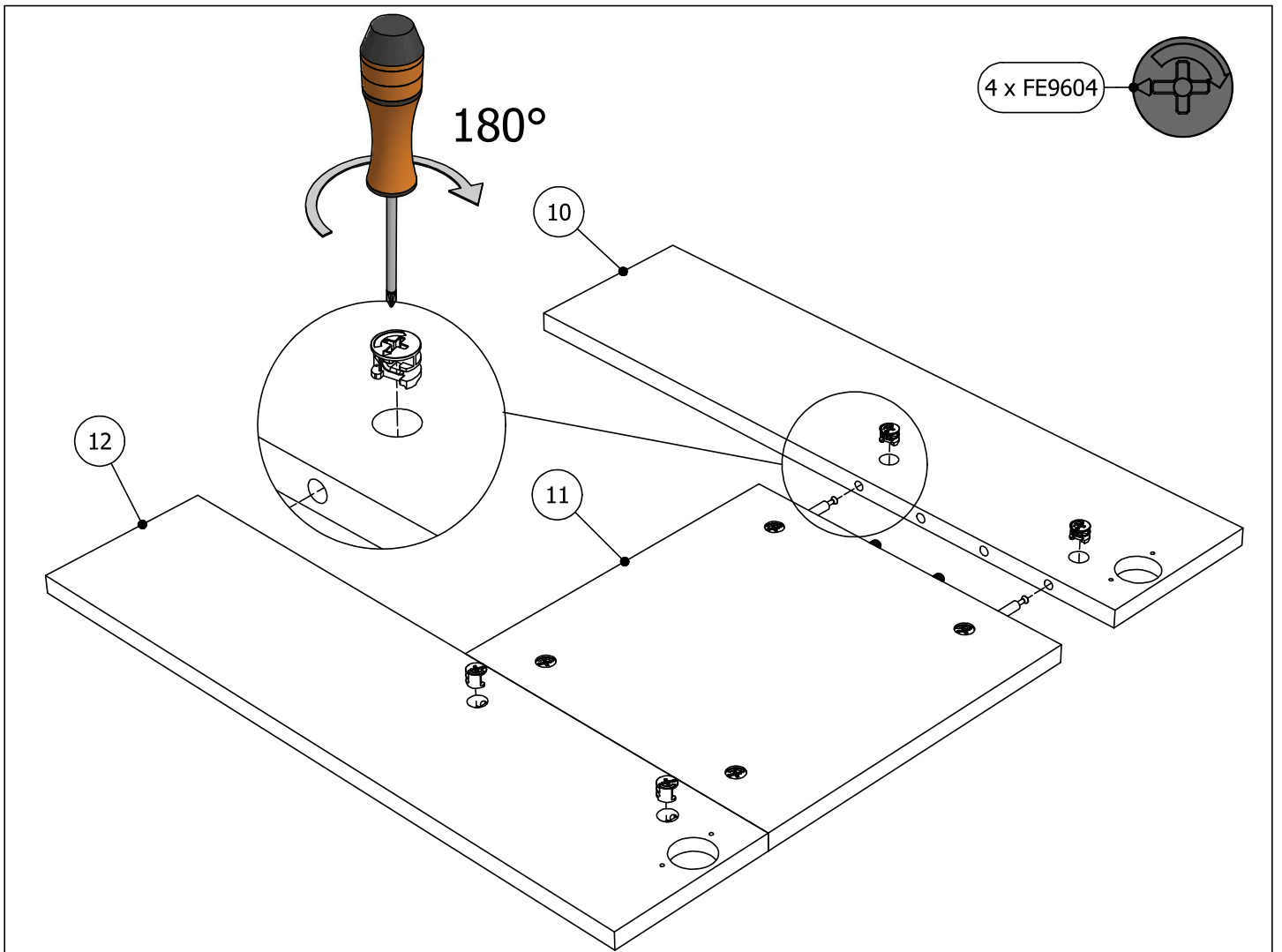

4 x FE9604

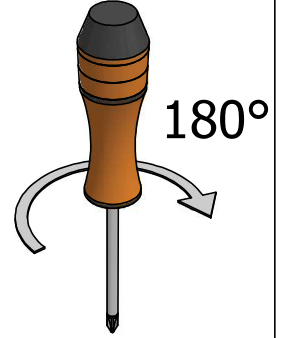
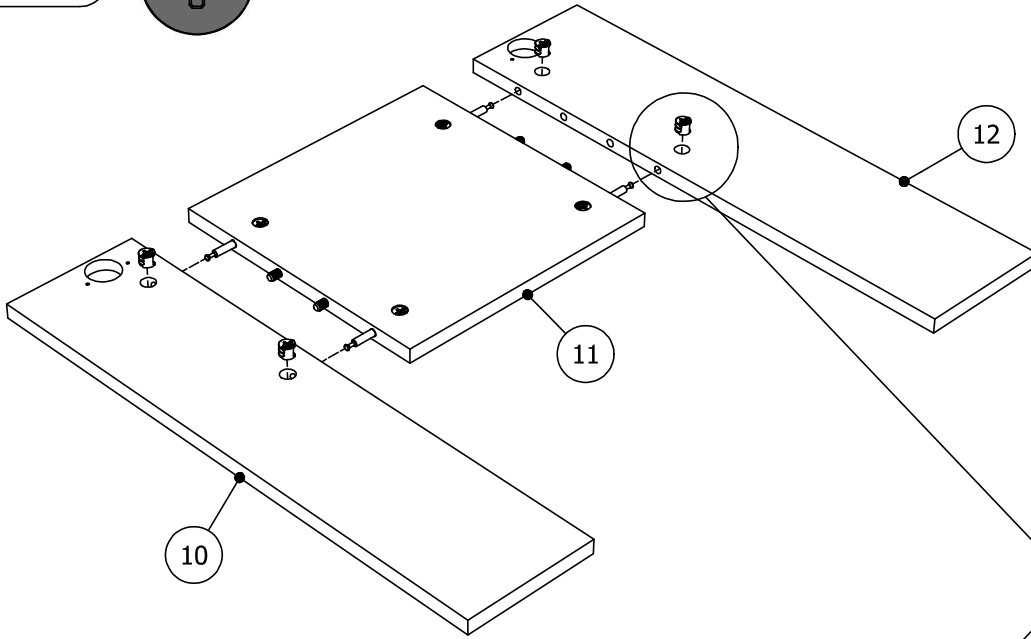
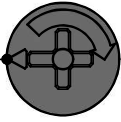

180°

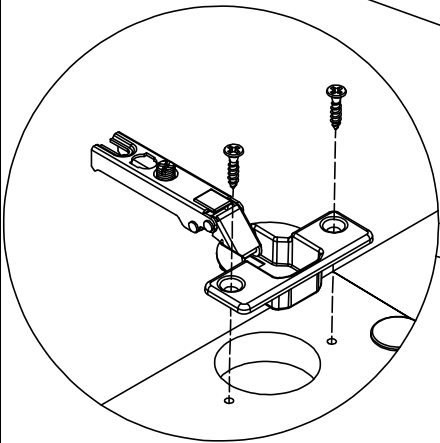
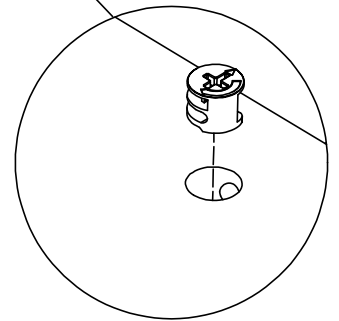

4 x FE9403 3,5x16



8 x FE9798

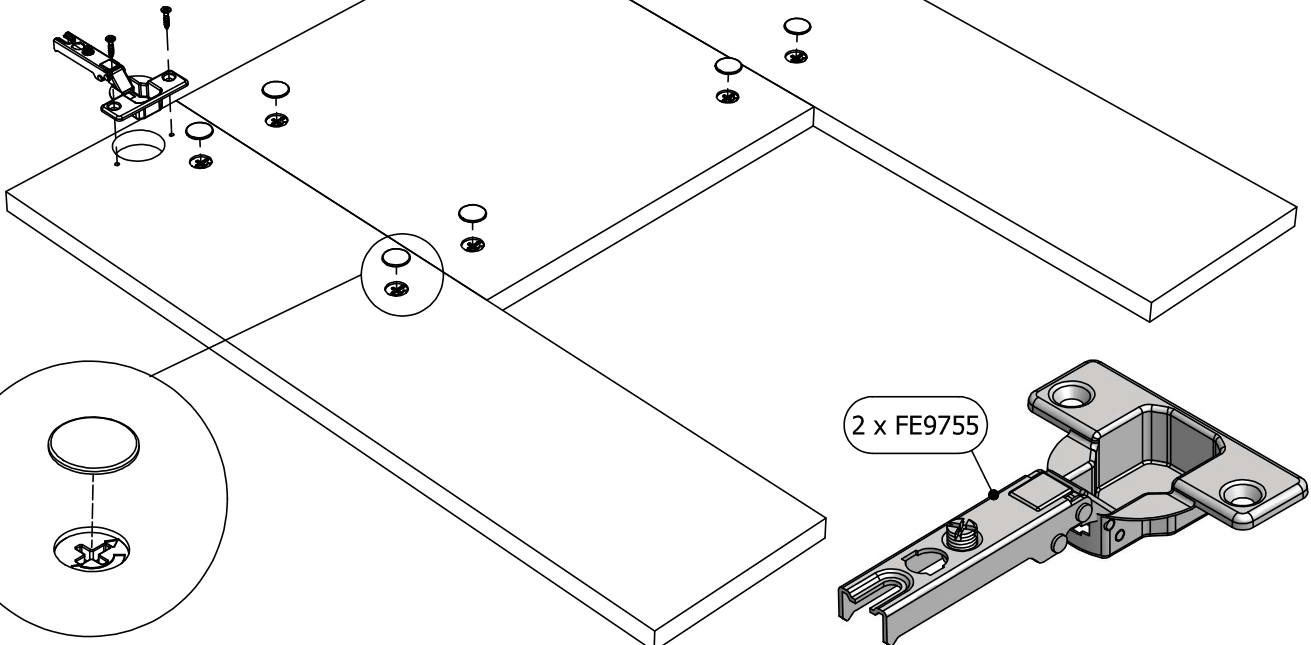
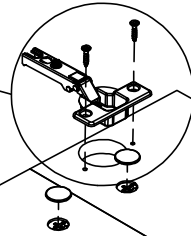
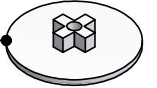

2 x FE9755

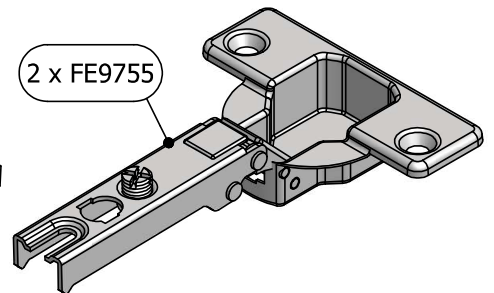

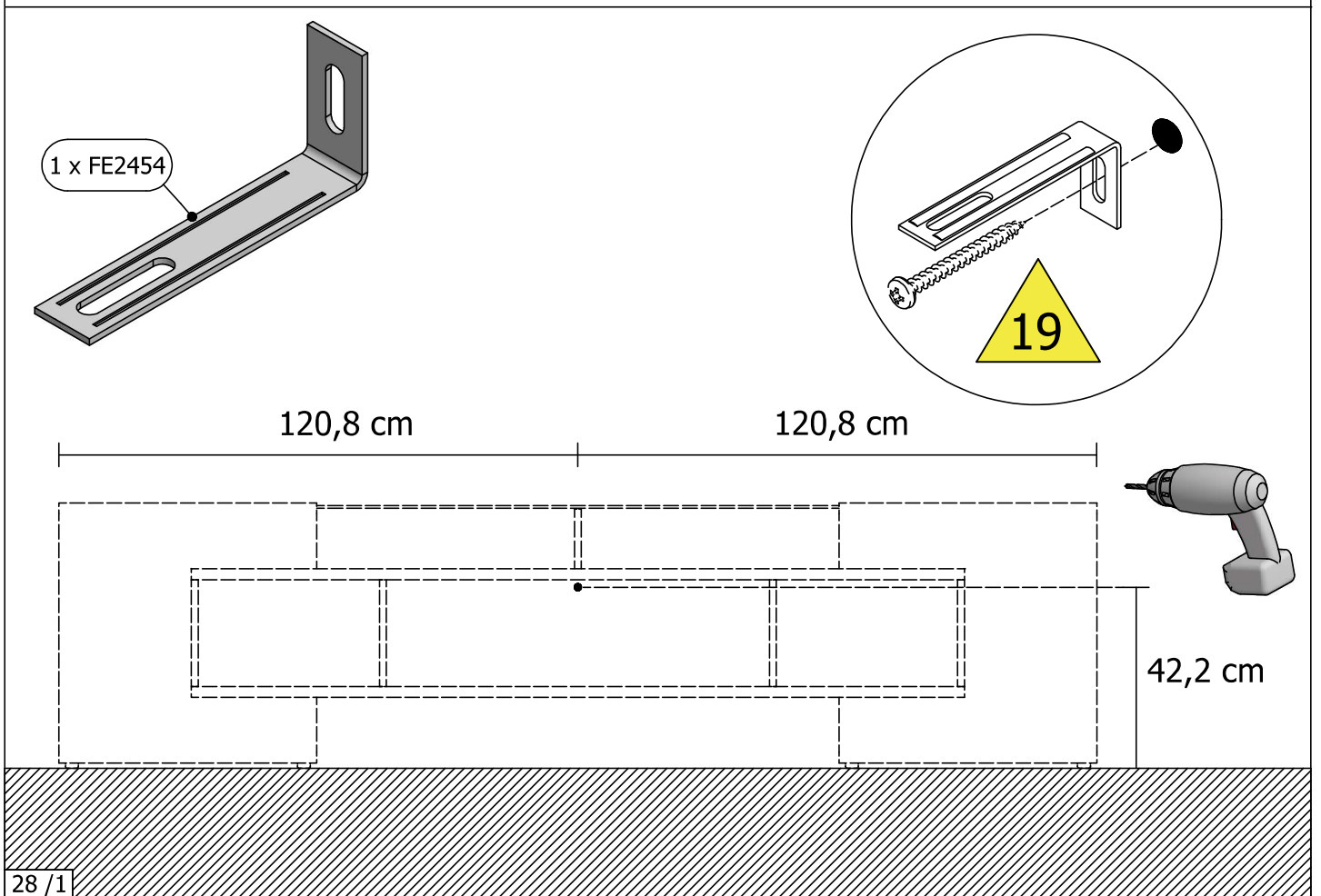
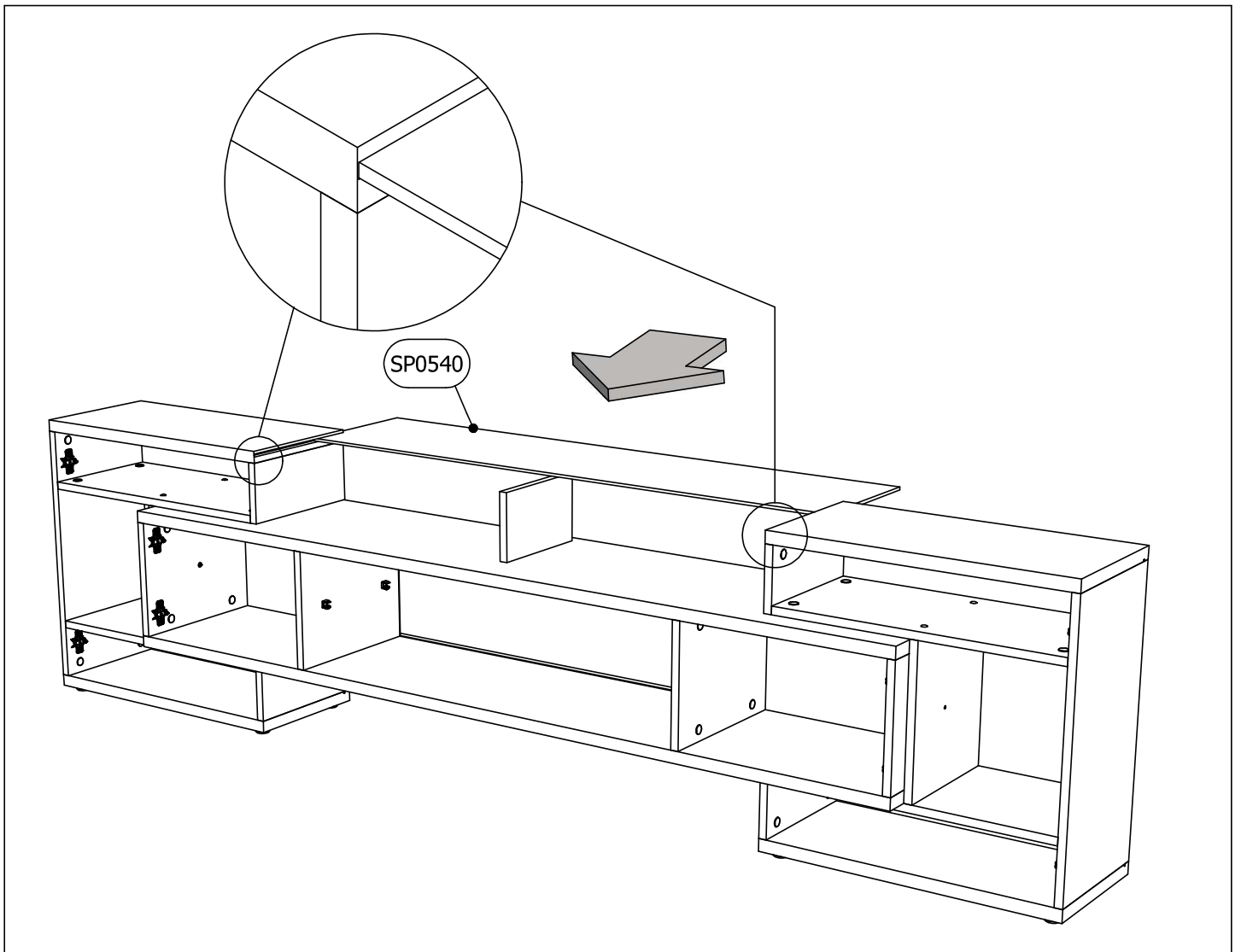

1 x FE9392 4x15

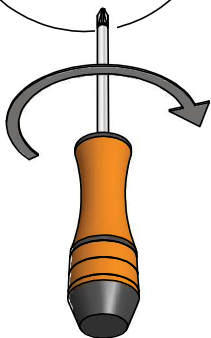
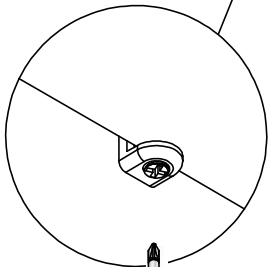
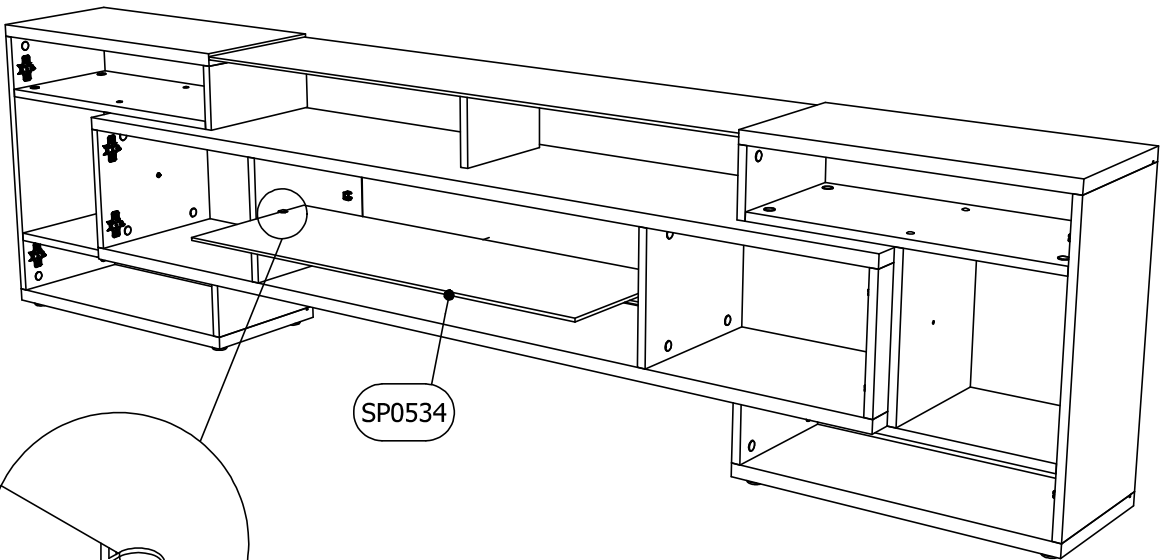
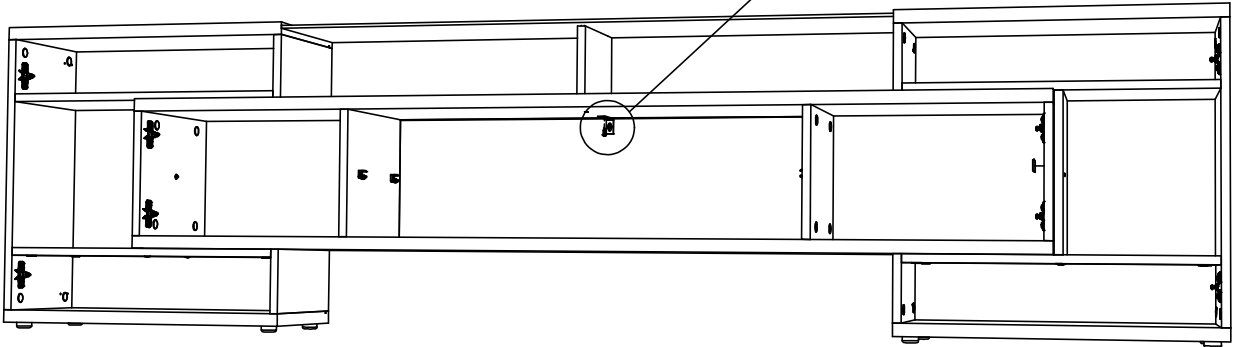
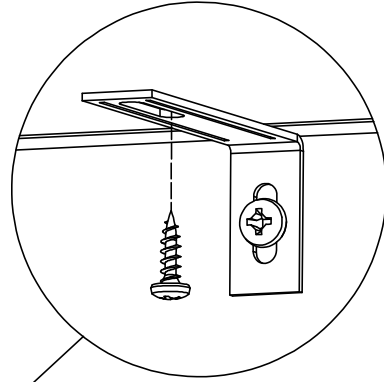
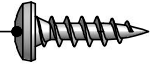

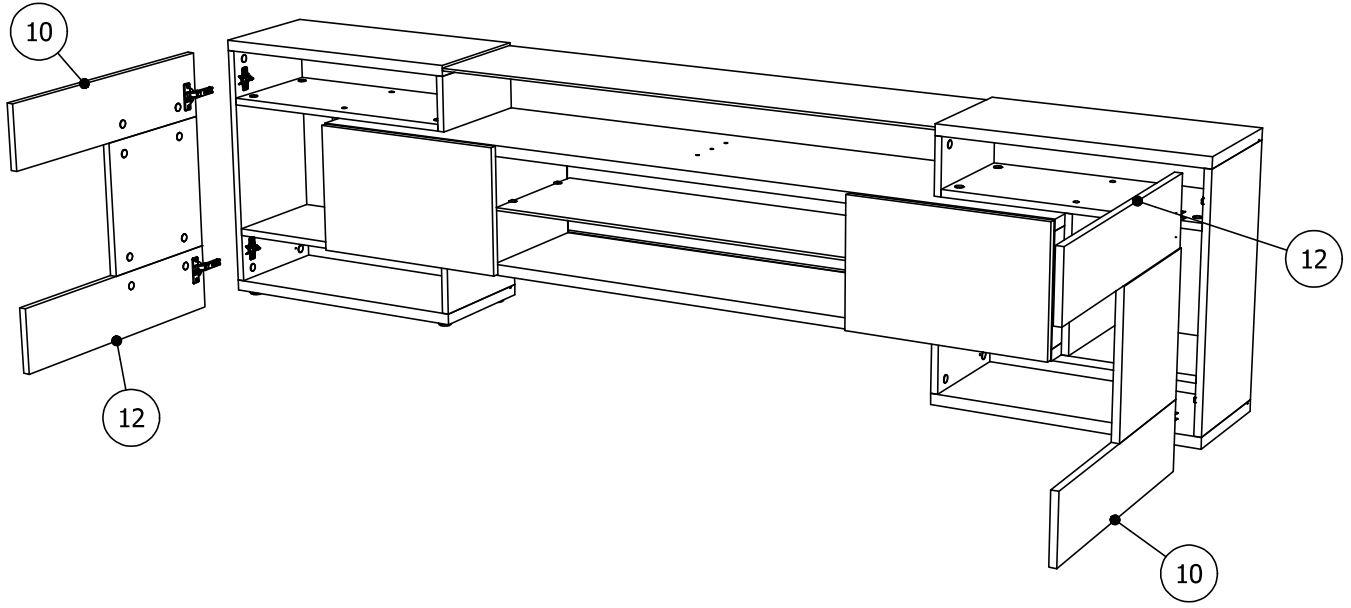
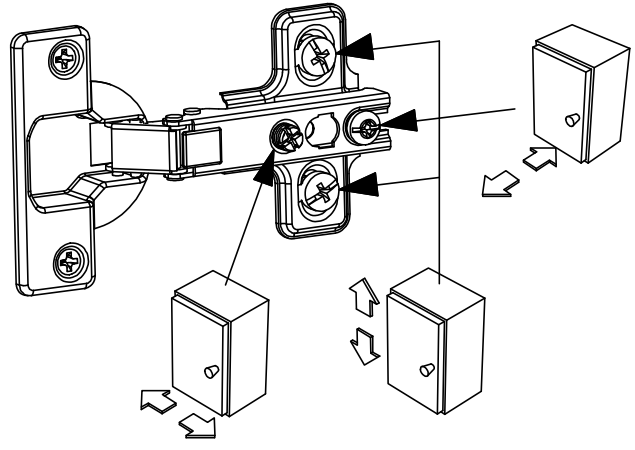
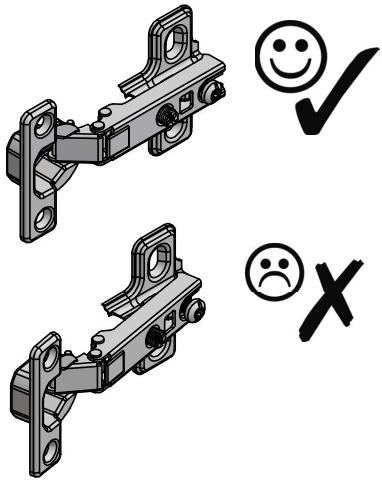
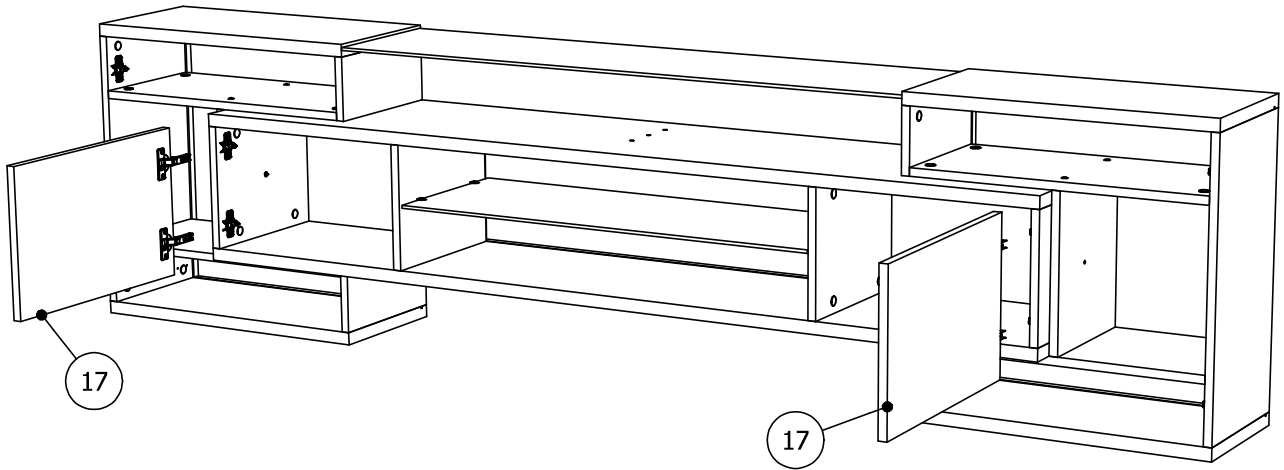

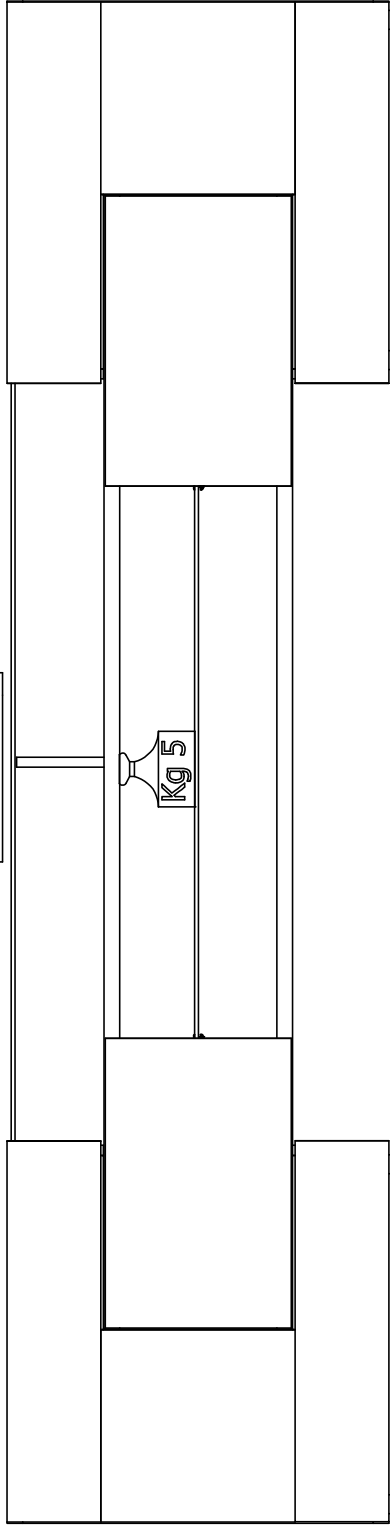
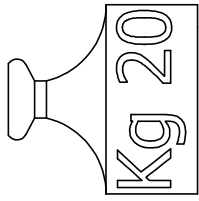
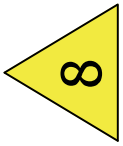

DE Pflegehinweise

Bitte nur mit einem Staubtuch oder leicht feuchtem Lappen reinigen. Keine scheuernden Putzmittel verwenden.

Schützen Sie Ihre Möbel generell vor Wasser (z.B. beim Wischen oder Blumen gießen). Die Feuchtigkeit kann in das Möbelstück eindringen und es beschädigen.

UK USA Care tips

Please only clean with a duster or a damp cloth. Do not use any abrasive cleaners. In general, keep water away from your furniture (e. g. when mopping or watering plants). The moisture may penetrate the furniture and damage it.

NL Reinigingsnotities

Reinig alleen met een stofdoek of een lichtjes vochtige doek. Gebruik geen schurende poetsmiddelen. Bescherm uw meubelen doorgaans tegen water (bijv. bij het dweilen of als u de bloemen water geeft). De vochtigheid kan in het meubelstuk dringen en het beschadigen.

PL Wskazówki dotyczące pielęgnacji

Czyszczenie należy wykonać wyłącznie za pomocą ściereczki lub lekko nawilżonego ręcznika. Nie stosować środków czyszczących do szorowania. Mebel należy chronić przed wodą (np. podczas czyszczenia lub podlewania kwiatków). Wilgoć może wnikać w mebel i uszkodzić go.

RU Обслуживание

Очищайте от пыли тряпкой или слегка влажной ветошью. Не допускается применение чистящих средств, не предназначенных для ухода за мебелью. Предохраняйте мебель от попадания воды (например, при вытирании или поливке цветов). Не допускайте попадания влаги на мебель, чтобы предотвратить ее повреждение.

RO Indicații de întreținere

Vă rugăm să utilizați la curățare exclusiv o cârpă de șters praful sau o cârpă ușor umezită. Nu utilizați substa
Protejați întotdeauna mobilierul contra apei (de exemplu la stergere sau la udarea florilor). Mobilierul poate fi afectat de umiditate și se poate deteriora. Nu utilizați abrazive.

ES Alertas de mantenimiento

Limpe sólo con un paño húmedo, no utilice disolventes. Proteja sus muebles de contacto con el agua. La infiltración de agua podría arruinar los muebles.

AR نصائح الرعاية

يرجى التنظيف فقط باستخدام منفضة أو قطعة قماش رطبة لا تستخدم أي منظفات خشنة أو كاشطة يمكن أن تخدش الأثاث بشكل عام، أبقِ الماء بعيداً عن الأثاث خاصة عند مسح الأرض أو سقي النباتات الرطبة قد تخترق الأثاث وتلفه

TR Bakım

Lütfen sadece bir toz beziyle veya hafif nemli yumuşak bir bezle siliniz. Aşındırıcı temizlik malzemeleri kullanmayınız. Genelde mobilyalarınızı sudan koruyunuz (örneğin, yerleri paspaslarken veya çiçekleri sularken). Nem, mobilya parçasına nüfuz edebilir ve zarar verebilir.

IT Avvisi di manutenzione

Pulire solamente con un panno umido, non utilizzare solventi. Proteggere i mobili dal contatto con acqua. L'infiltrazione dell'acqua potrebbe rovinare il mobile.

FR Conseil d'entretien

Nettoyer avec un plumeau ou un chiffon humide. Ne pas utiliser de dissolvants. En général, garder l'eau loin de vos meubles (par exemple lors de lavages, ou bien pour l'arrosage des plantes). L'humidité peut pénétrer les meubles et les endommager.

CZ Ošetřování

Čistěte prosím jen prachovkou nebo lehce navlhčeným hadrem. Nepoužívejte drhnoucí čisticí prostředky. Chraňte váš nábytek před vodou (např. při utírání prachu nebo zalévání květin). Vlhkost může do nábytku proniknout a poškodit ho.

SK Ošetrovanie

Na čistenie používajte len prachovku alebo zľahka navlhčenú utierku. Nepoužívajte žiadne drhnúce čistiace prostriedky. Chráňte váš nábytok celkovo pred vodou (napr. pri utieraní alebo polievaní kvetín). Vlhkosť môže vniknúť do nábytku a poškodiť ho.

HU Ápolási tanácsok

Kérjük, csak portörölő kendővel vagy enyhén nedves ronggyal tisztítsa. Ne használjon dörzsölhető tisztítószert. Védje a bútort a víz ellen (pl. a letörölések során, ill. a növények öntözésekor). A nedvesség behatolhat a bútortá és azt tönkre teheti.

PT Alertas de manutenção

Limpe apenas com um pano úmido, não use solventes. Proteja sua mobília de contacto com a água. A infiltração de água pode arruinar o mobiliário.

