

TOKYO Nr9

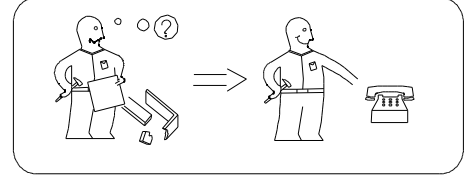

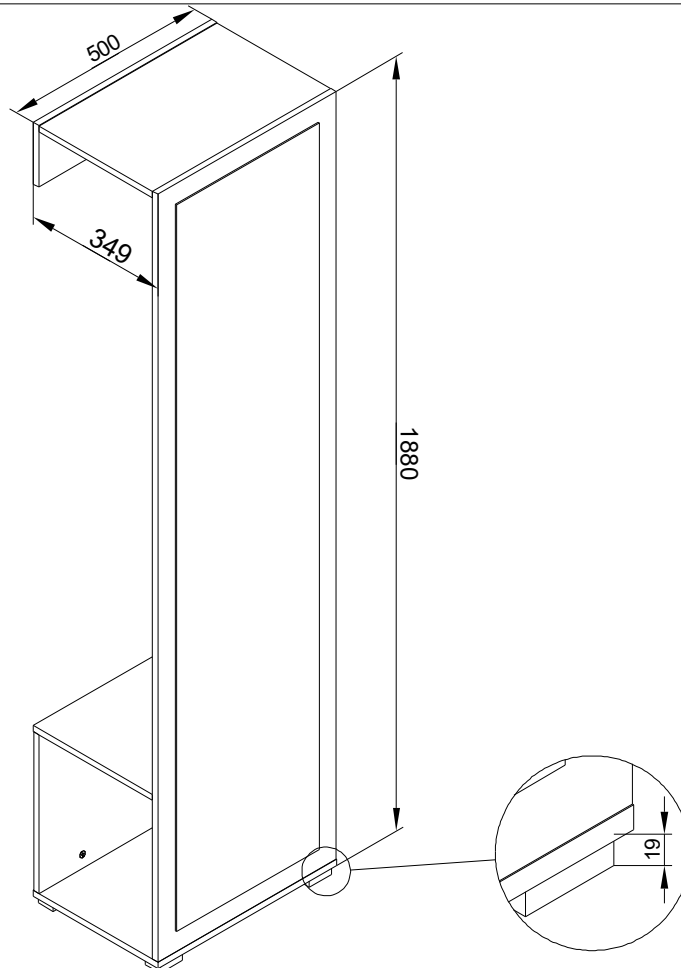

- PL** Instrukcja montażu
CZ Instrukce k instalaci
D Montageanleitung
GB Assembly instruction
F Midel d'emploi
HU Szerelési útmutató
I Istruzione di montaggio
NL Handleiding voor de montage
RU Инструкция по установке
RO Instrucțiuni de instalare
SK Návod na inštaláciu
TR Montaj talimati







Uwaga . Upozornini . Achtung . Attention . Caution . Fıryelem Attenzione . Opgelet . внимание . Atentie . Upozornenie . Dikkat			
PL	Czyszczenie należy wykonywać wyłącznie za pomocą ściereczki lekko nawilżonego ręcznika. nie stosować środków czyszczących do szorowania.	I	La pulizia deve essere eseguita solo con un panno e un asciugamano leggermente inumidito. non utilizzare agenti abrasivi.
CZ	Čištění by se mělo provádět pouze hadříkem a mírně navlhčeným ručníkem. nepoužívejte abrazivní prostředky.	NL	Reinig alleen met een stofdoek of lichtjes met een vochtige doek. Gebruik geen schurende of bijtende poetsmiddelen.
D	Bitte nur mit einem Staubtuch oder leicht feuchtem Lappen reinigen. Keine scheuernden Putzmittel verwenden.	RU	Чистку следует производить только тряпкой, слегка смоченной полотенцем. не используйте чистящие средства.
GB	Please only clean with a duster or a damp cloth. Do not use any abrasive cleaners.	RO	Curatare trebuie efectuata numai cu o carpa sau cu un prosop usor umezit. Nu utilizati agenti de curatare abrazivi.
F	Le nettoyage doit être effectué uniquement avec un chiffon, une serviette légèrement humidifiée. n'utilisez pas d'agents à récurer.	SK	Čistenie by sa malo uskutočňovať iba pomocou handričky a mierne navlhčeného uteráka. nepoužívajte drsné prostriedky.
HU	A tisztítást csak ruhával, enyhén megnedvesített törülköz övel szabad elvégezni. ne használjon tisztítószert a súroláshoz.	TR	Temizlik sadece bezle, hafif çe nemlendirilmi ş havluyla yapılmalıdır. ovma maddeleri kullanmayın.











I-II

	3,5x16 			
ZD x1	H6 x1	D x9	B x6	A x4

III-V

4x25 				
G1 x8	M x4	A x6	B x6	D x9

VI-XIII



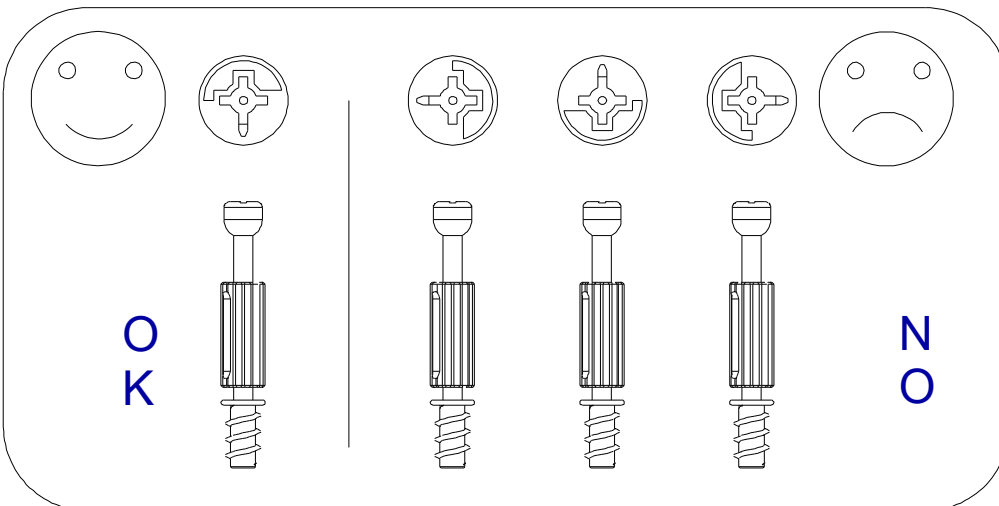
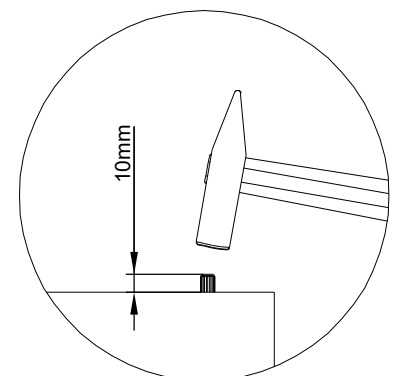
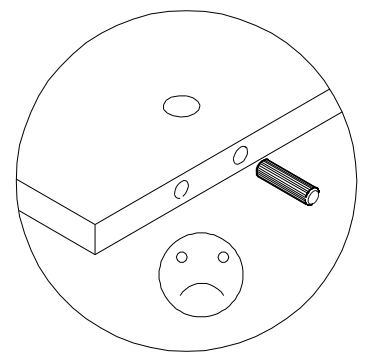

		3,5x16 			Ø10x50 	3x13 	
Y1 x2	A x2	H6 x1	ZD x1	X x12	KR x2	H x4	D1 x1

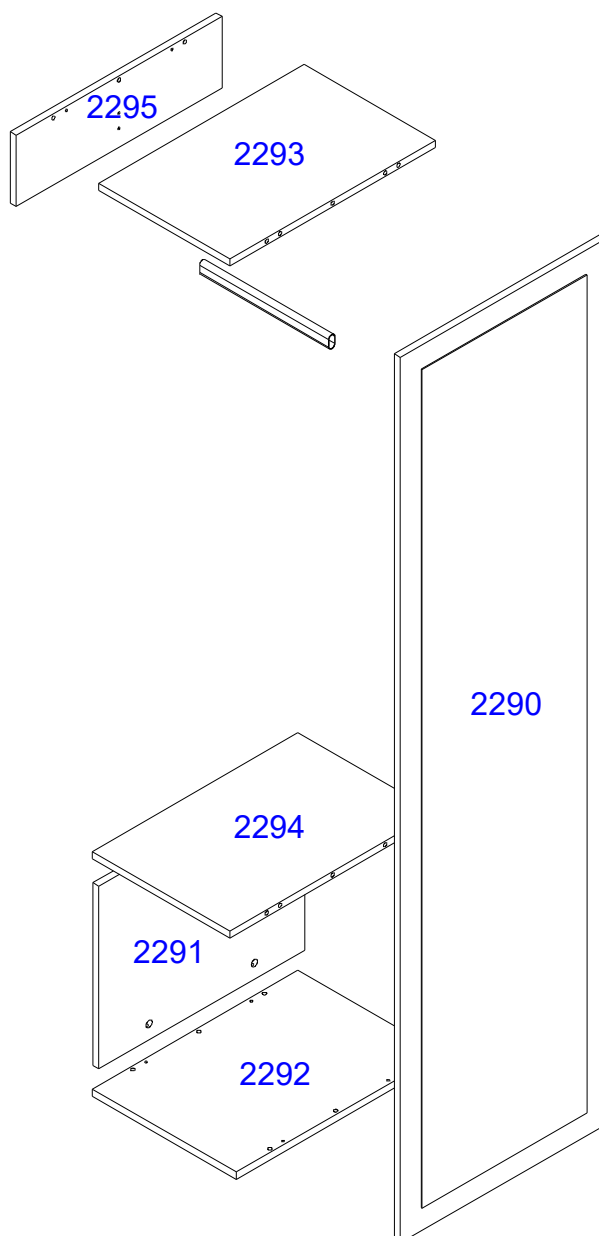
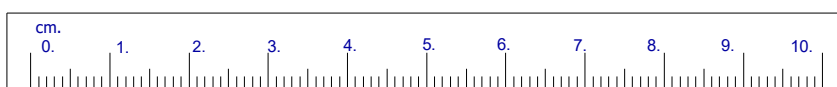
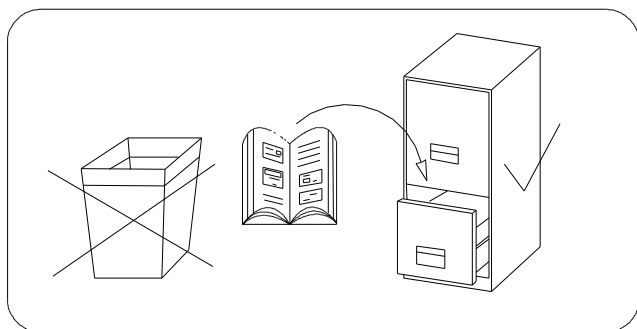



TOKYO Nr9

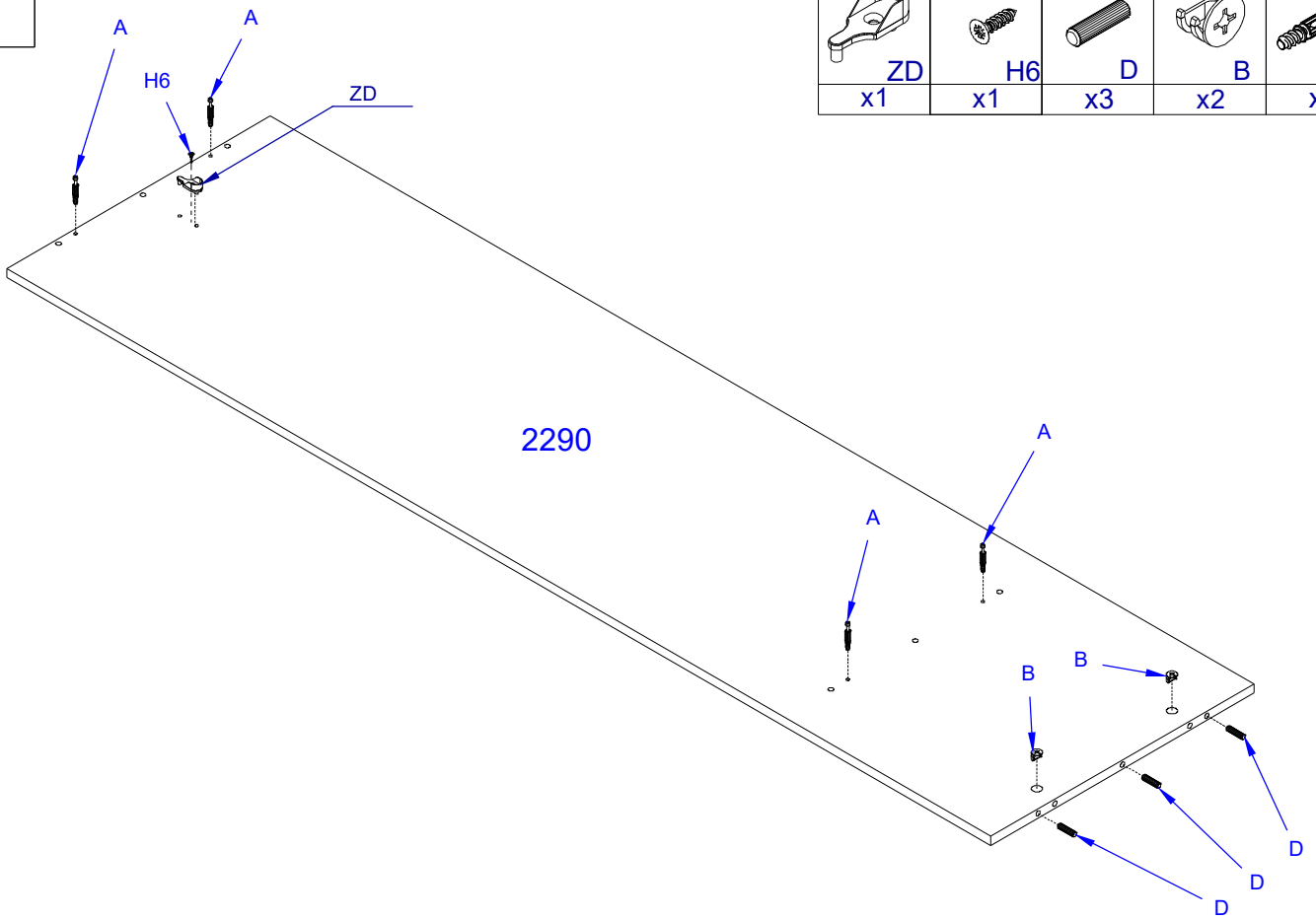

I

				
ZD	3,5x16	D	B	A
x1	x1	x3	x2	x4

**II**

	
B	D
x4	x6

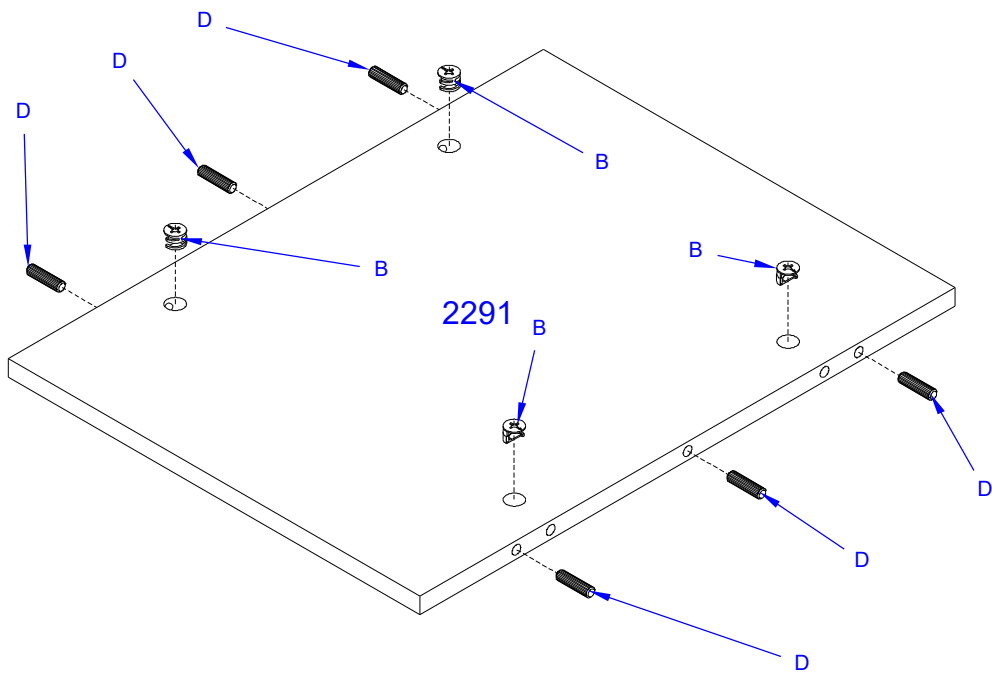



4x25			
	G1	M	A
x8	x4	x4	

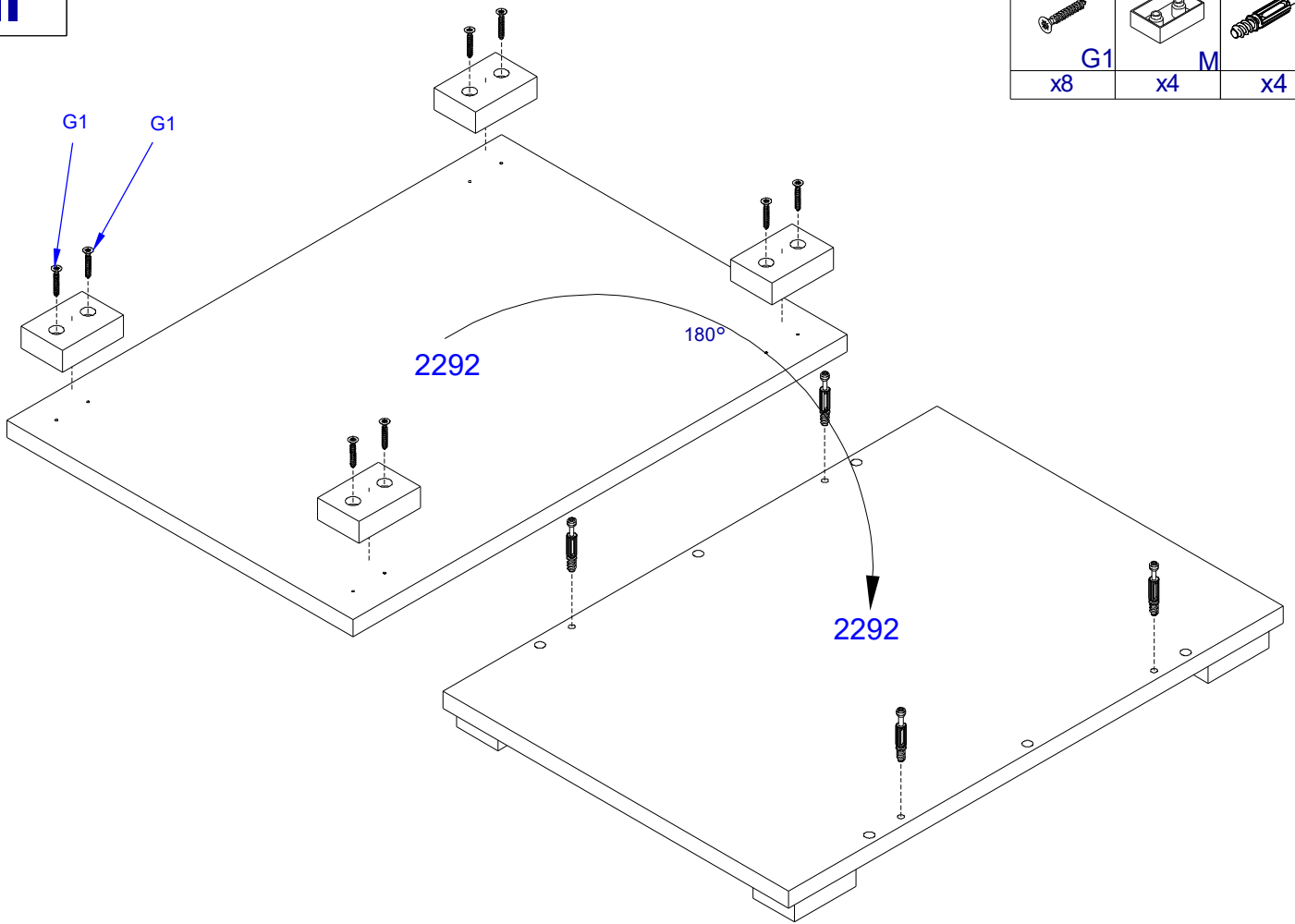



IV

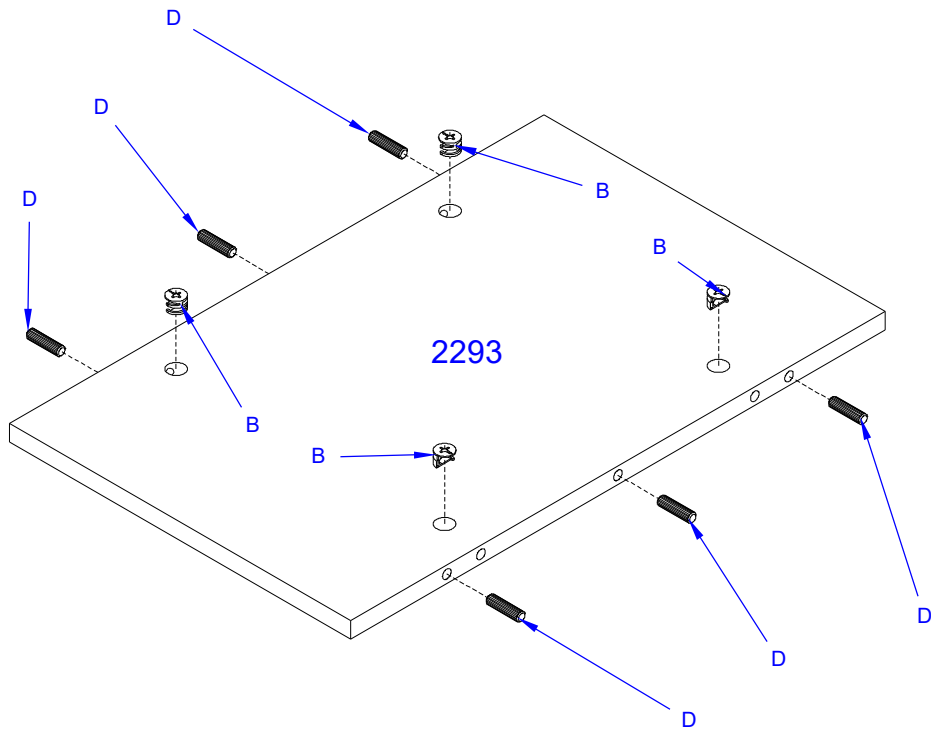



B	D
x4	x6

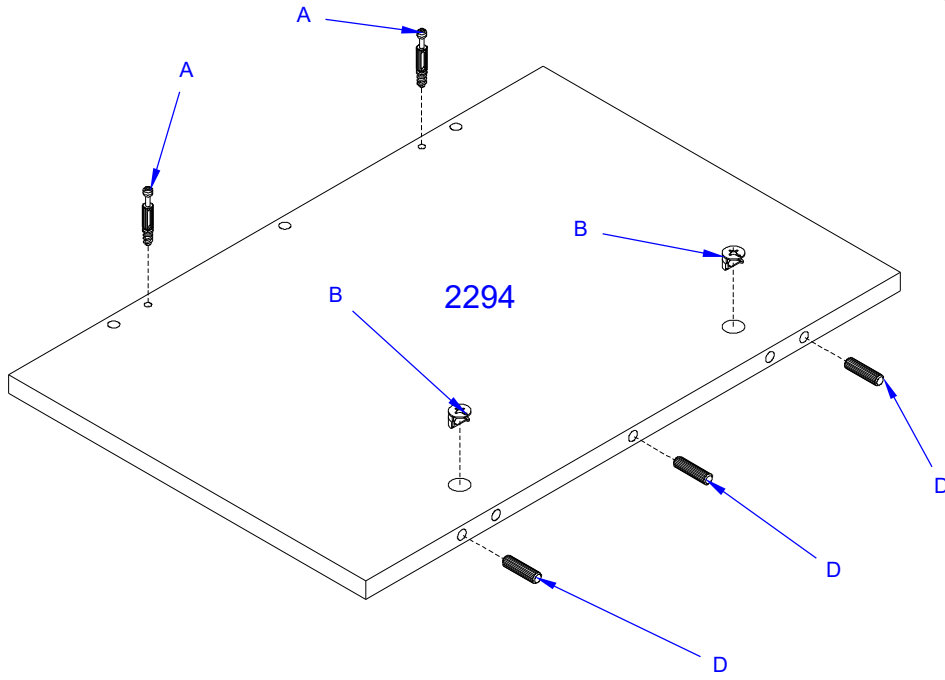

V

		
A	D	B
x2	x3	x2

**VI**

			
Y1	A	H6	ZD
x2	x2	x1	x1
			
			3x13
			x4

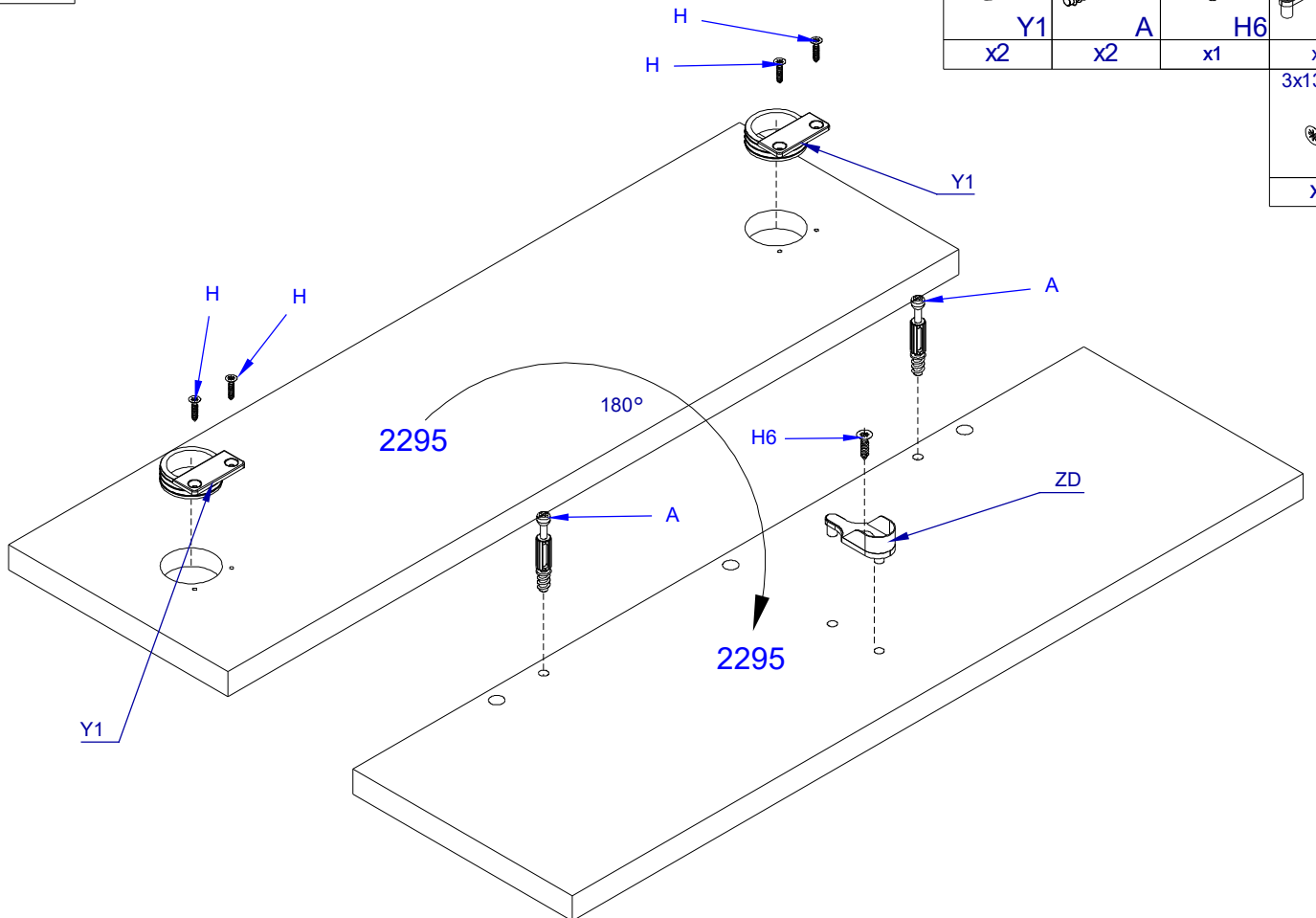

VII

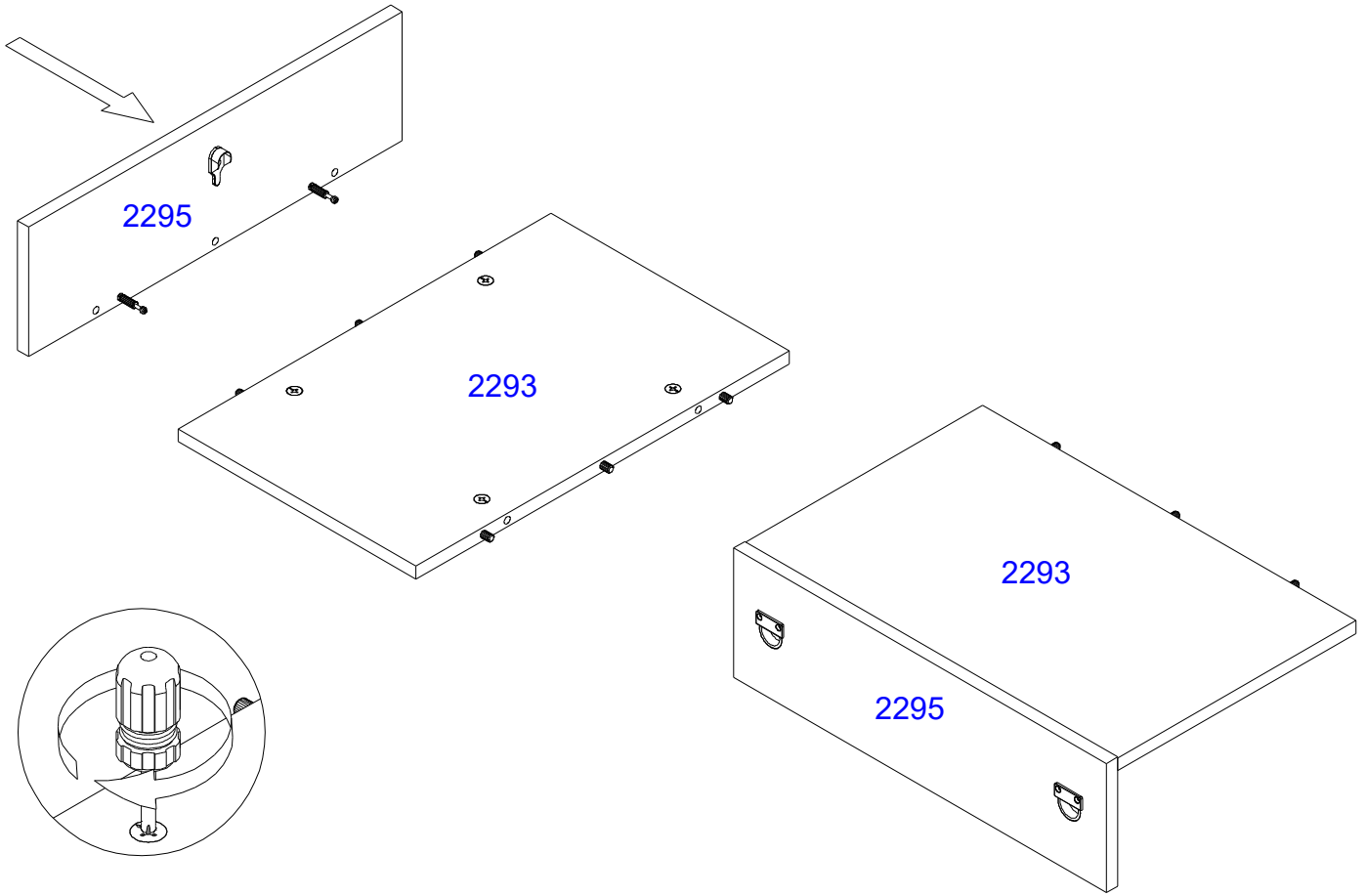

VIII

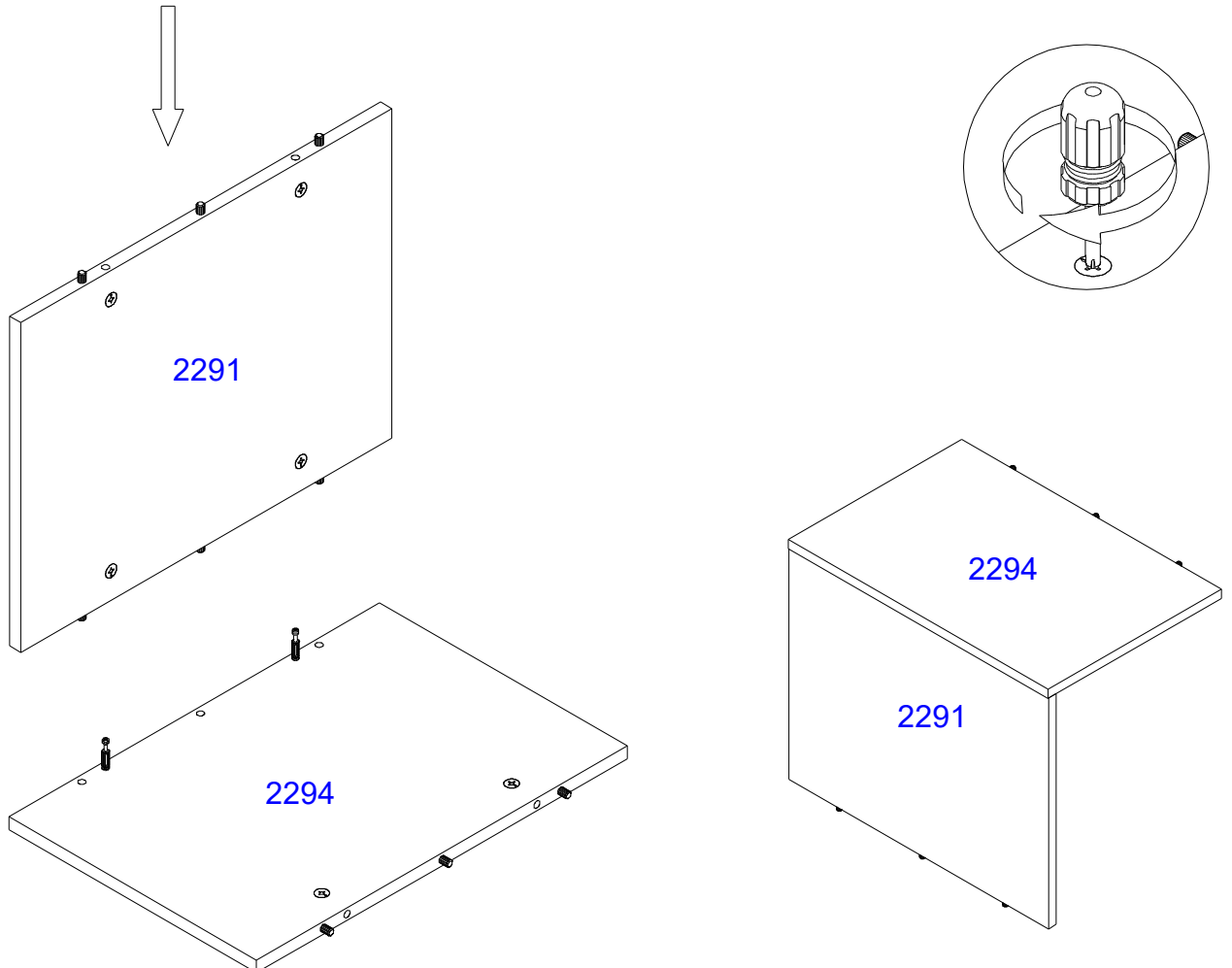

IX

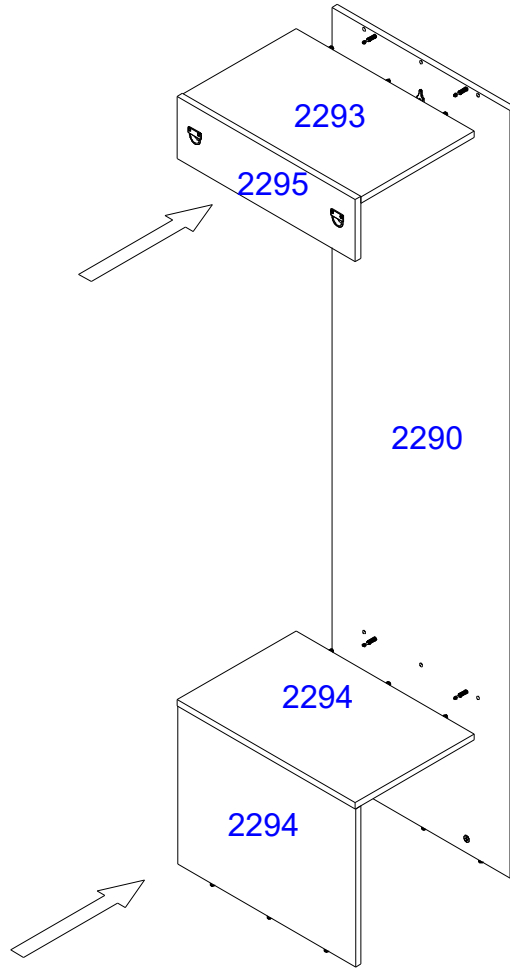
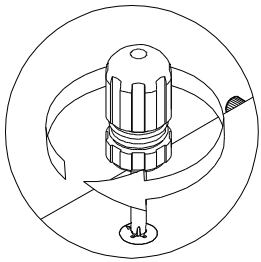

X

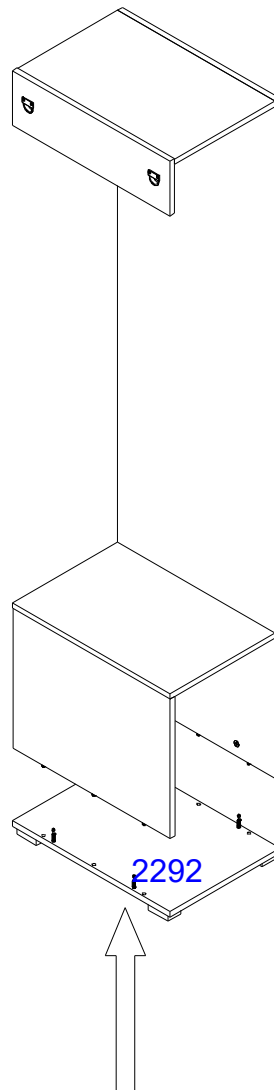
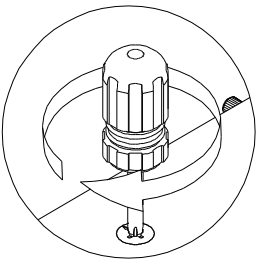

XI

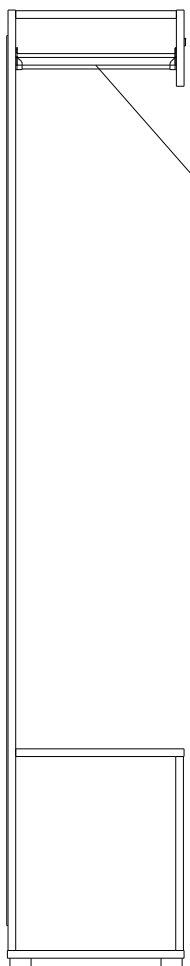

D1

x1

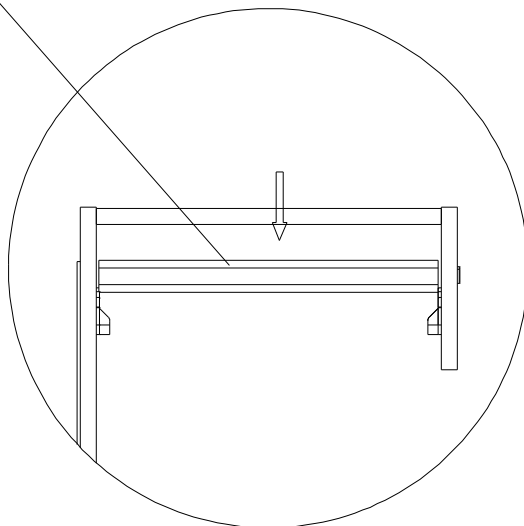

XII

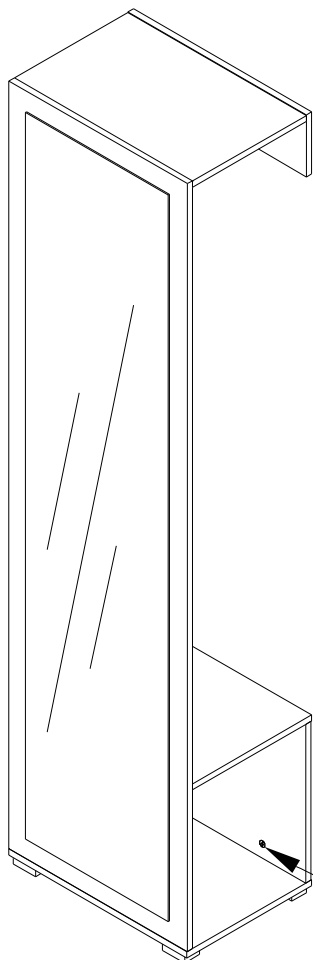

X

x12

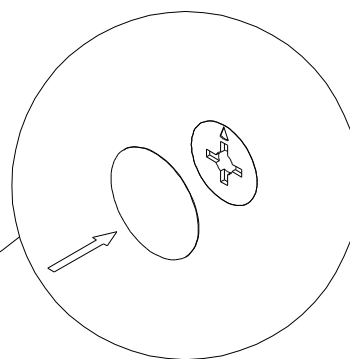

XIII

Ø10x50
KR
x2

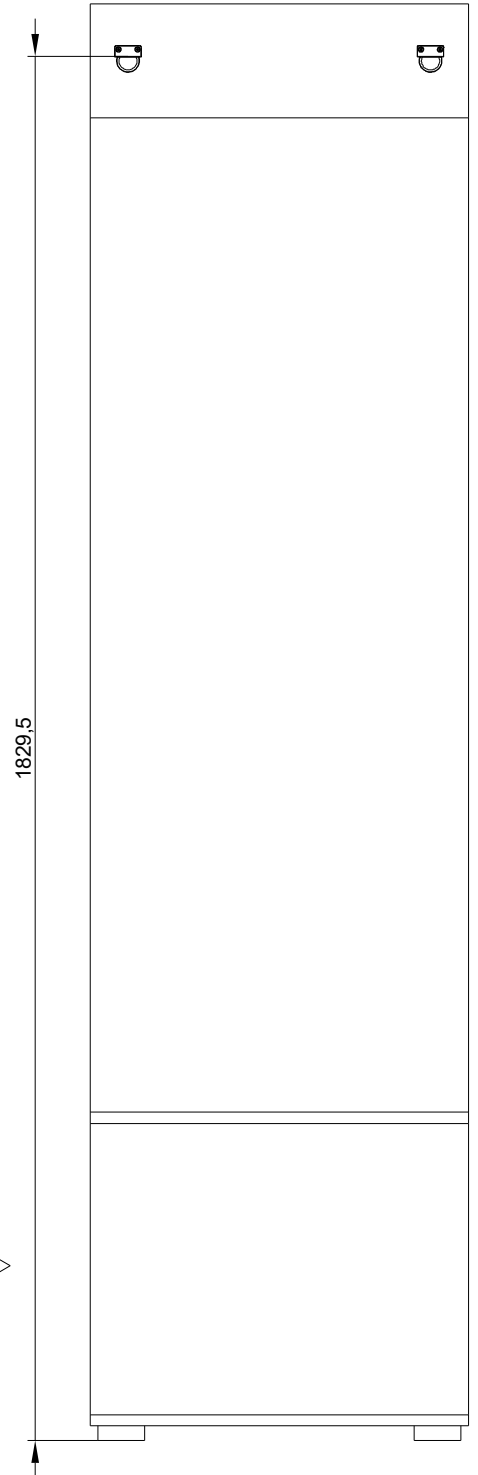
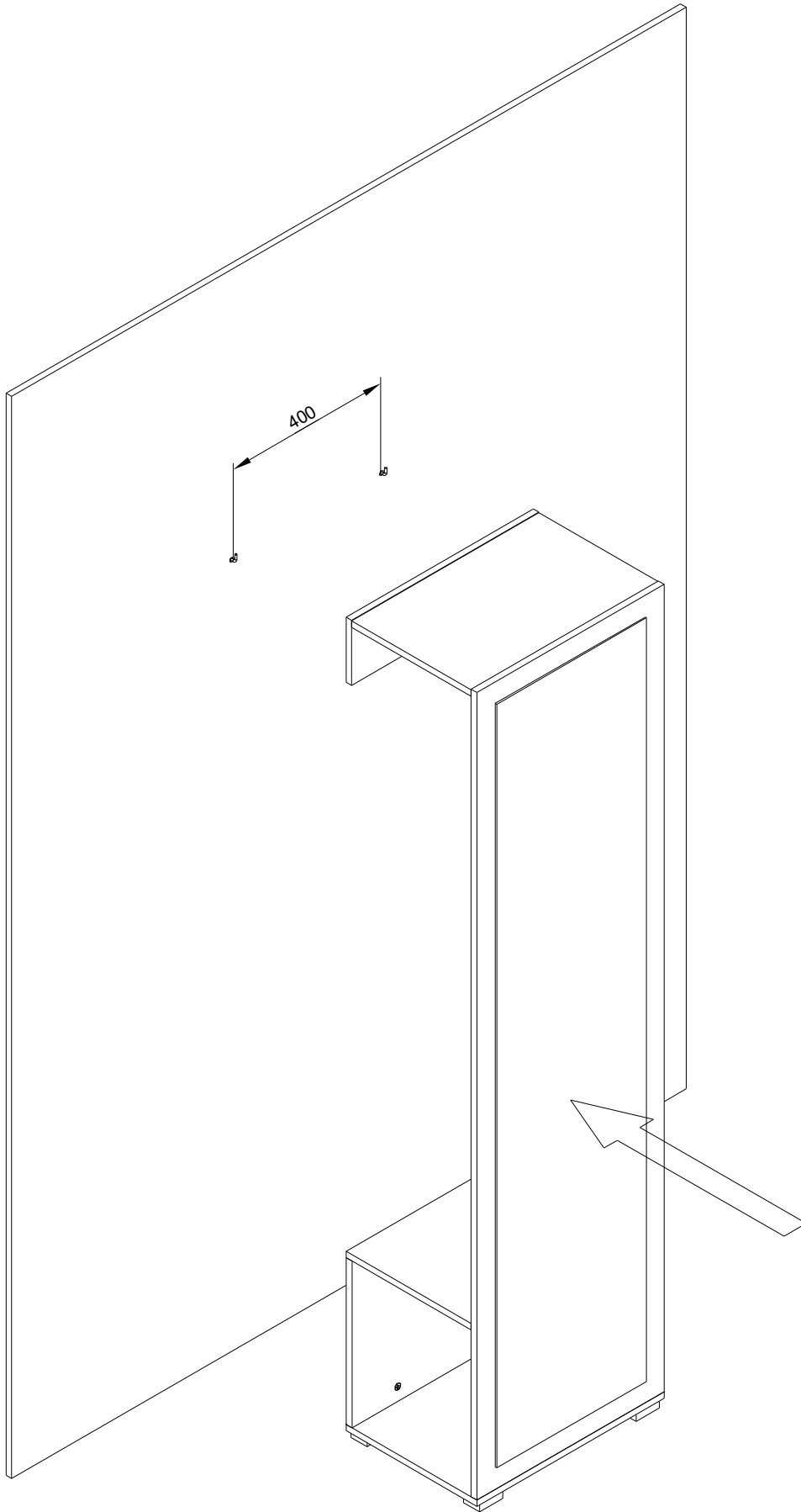



**Uwaga . Upozornini . Achtung . Attention . Caution . Figyelem
Attenzione . Opgelet . Внимание . Atentie . Upozornenie . Dikkat**



PL

Załączony zestaw montażowy do zamocowania artykułu do ściany (kołki wkręty, haki itp.), przeznaczony jest wyłącznie do montażu artykułu na ścianach wykonanych z cegły lub betonu. Przy montażu artykułu na ścianie wykonanej z innych materiałów, należy zastosować odpowiednie do niej zamocowania. W razie wątpliwości prosimy zasięgnąć porady fachowca.
Uwaga: Mocowanie mebla do ściany mogą przeprowadzić wyłącznie wykwalifikowane osoby z uwagi na zastosowanie odpowiednio dopasowanych kołków do rodzaju ściany.

CZ

Příložený materiál pro montáž na stěnu (hmoždinky a šrouby) je vhodný jen pro pevné zdivo (např. betonové nebo cihlové stěny). Pro jiné skladby stěn budou případně nutné speciální hmoždinky a jiné šrouby. Porad'te se případně s odborníkem.
Pozor: Montáž nábytku na stěnu musí provést odborník, protože k montáži na stěnu jsou zapotřebi upravené hmoždinky.

D

Das beigefügte Wandbefestigungsmaterial (Dübel und Schrauben) eignet sich nur für festes Mauerwerk (z.B. Beton- oder Ziegelwände) . Für andere Wandaufbauten sind eventuell Spezialdübel und andere Schrauben notwendig. Ziehen Sie gegebenenfalls eine Fachkraft zurate.
Achtung: Die Befestigung des Möbelstückes an der Wand muss von einer fachkundigen Person vorgenommen werden da für die Montage an die Wand angepasste Dübel erforderlich sind.

GB

The enclosed wall mounting materials (dowels and screws) are only suitable for solid masonry (e . g. concrete or brick walls) . Special dowels and other screws may be necessary for other wall constructions. If necessary, please consult a qualified professional.
Attention: A qualified professional is required when mounting furniture to the wall since dowels corresponding to the wall are required for this.

F

Le matériel de fixation murale fourni (chevilles et vis) convient uniquement a des murs solides (p.ex. murs en béton ou en briques) . Pour les autres constructions de murs, il faut éventuellement des chevilles spéciales et d'autres vis. Faites-vous conseiller par un spécialiste.
Attention: La fixation du meuble contre le mur doit être effectuée par une personne compétente car, pour le montage mural, il faut utiliser des chevilles adaptées.

HU

A mellekelt fali rögzítőkeszlet (tiplé és csavarok) csak tömött falazatban (pi. betonfalban , teglafalban) használható . Mas faltípusokhoz speciális tiplire és csavarra lesz szükseg. Szükseg eseten kerje ki egy szakember véleményét
Figyelem : A butorelemek falra rögzítését szakembernek kell végeznie, mert a rögzítéshez megfelelő tiplit kell használni .

I

I materiali di fissaggio allegati (tasselli e viti) sono adatti solo ai muri compatti (ad esdi calcestruzzo o mattoni) Per altri tipi di pareti e probabile Che occorran tasselli speciali e altre tipologie di viti. Richiedere eventualmente il consiglio di un esperto.
Attenzione: Il fissaggio del mobile alla parete deve essere eseguito da persone esperte dato ehe occorrono tasselli adeguati

NL

Het bijgeleverde bevestigingsmateriaal (pluggen en schroeven) is geschikt voor vaste muren (betonnen of bakstenen muren). Voor andere muurconstructies zijn eventueel speciale pluggen en andere schroeven nodig. Raadpleeg indien nodig een specialist.
Opgelet: een specialist dient het product aan de muur te bevestigen om te bepalen welk bevestigingsmateriaal gebruikt moet worden.

RU

Входящий в комплект поставки материал для крепления на стене (дюбели и болты) предназначен только для прочных каменных стен (например, бетонных или кирпичных). Для других типов стен используйте по мере необходимости специальные дюбели и другие болты. По мере необходимости обратитесь за помощью к специалистам.
Внимание: Поскольку для монтажа на стене необходимо использовать специальные дюбели, мебель должна быть закреплена на стене квалифицированным персоналом.

SK

Příložený materiál pro upevnenie na stenu (hmoždinky a skrutky) je vhodný jen pre pevné murivo (napr. betónové alebo tehlové steny). Pre iné steny sú potrebné príp. nutné speciálne hmoždinky a jiné šrouby. Porad'te se případně s odborníkem.
Pozor: Montáž nábytku na stěnu musí provést odborník, protože k montáži na stěnu jsou zapotřebi upravené hmoždinky.

TR

Teslimat kapsamındaki duvar tipi sabitleme materyali (dübel ve vidalar) sadece beton ve tuğla duvarları gibi sağlam duvar yapıları için uygundur. Başka duvar yapıları için özel dübeller veya başka vidalar gerekli olabilir. Gerekirse bir uzmandan yardım alınız.
Dikkat: Mobilya parçasının duvara sabitlenmesi, duvar montaj için özel uyarlanmış dübeller gerektirdiğinden bu iş sadece bu konuda uzman bir kişi tarafından gerçekleştirilmelidir.

TOKYO Nr20



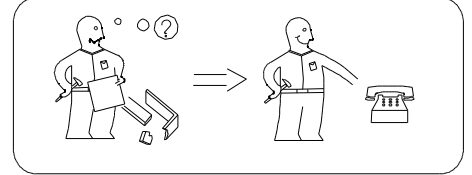
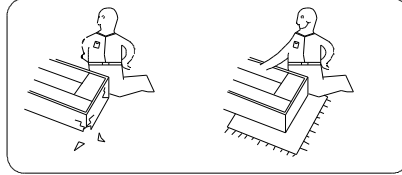
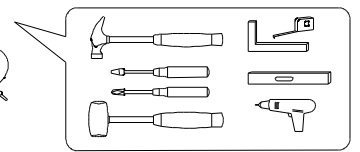
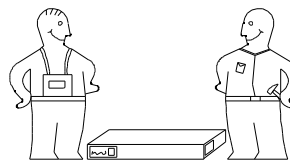

- PL** Instrukcja montażu
CZ Instrukce k instalaci
D Montageanleitung
GB Assembly instruction
F Midel d'emploi
HU Szerelési útmutató
I Istruzione di montaggio
NL Handleiding voor de montage
RU Инструкция по установке
RO Instructiuni de instalare
SK Návod na inštaláciu
TR Montaj talimati

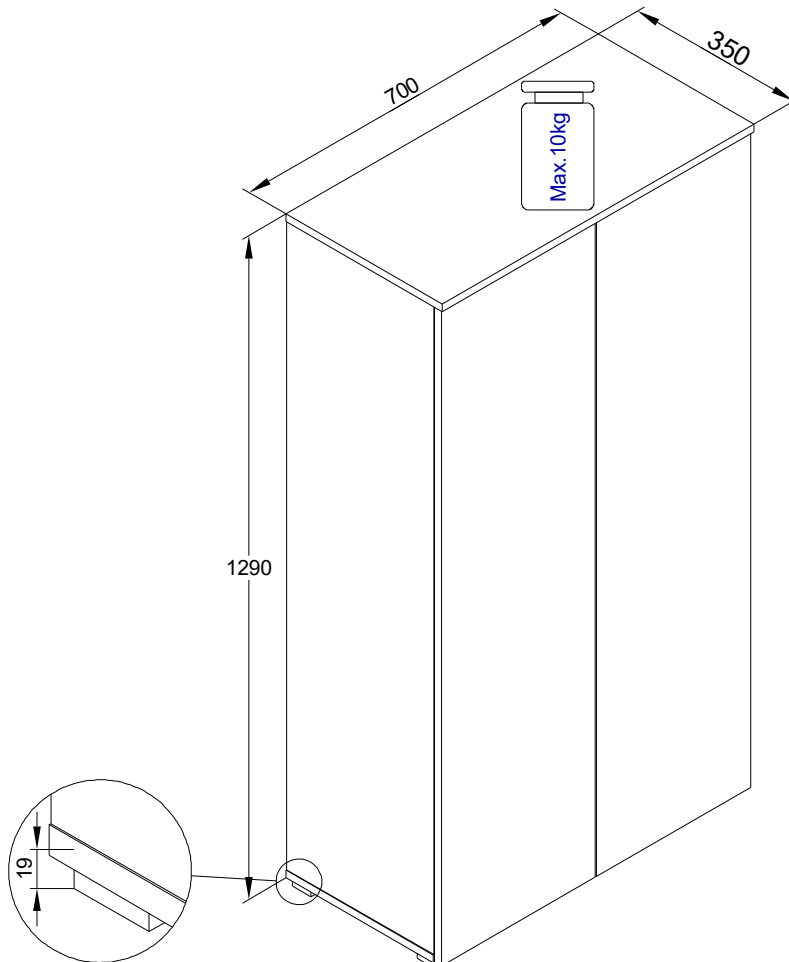





Uwaga . Upozornini . Achtung . Attention . Caution . Firyelem Attenzione . Opgelet . внимание . Atentie . Upozornenie . Dikkat			
PL	Czyszczenie należy wykonywać wyłącznie za pomocą ściereczki lekko nawilżonego ręcznika. nie stosować środków czyszczących do szorowania.	I	La pulizia deve essere eseguita solo con un panno e un asciugamano leggermente inumidito. non utilizzare agenti abrasivi.
CZ	Čištění by se mělo provádět pouze hadříkem a mírně navlhčeným ručníkem. nepoužívejte abrazivní prostředky.	NL	Reinig alleen met een stofdoek of lichtjes met een vochtige doek. Gebruik geen schurende of bijtende poetsmiddelen.
D	Bitte nur mit einem Staubtuch oder leicht feuchtem Lappen reinigen. Keine scheuernden Putzmittel verwenden.	RU	Чистку следует производить только тряпкой, слегка смоченной полотенцем. не используйте чистящие средства.
GB	Please only clean with a duster or a damp cloth. Do not use any abrasive cleaners.	RO	Curatare trebuie efectuată numai cu o carpa sau cu un prosop ușor umezit. Nu utilizați agenți de curatare abrazivi.
F	Le nettoyage doit être effectué uniquement avec un chiffon, une serviette légèrement humidifiée. n'utilisez pas d'agents à récurer.	SK	Čistenie by sa malo uskutočňovať iba pomocou handričky a mierne navlhčeného uteráka. nepoužívajte drsné prostriedky.
HU	A tisztítást csak ruhával, enyhén megnedvesített törülközővel szabad elvégezni. ne használjon tisztítószerrel a súroláshoz.	TR	Temizlik sadece bezle, hafifçe nemlendirilmiş havluyla yapılmalıdır. ovma maddeleri kullanmayın.







I

			
B	D	S	L
x8	x8	x20	x6

II-III

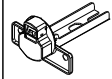
	 4x25		
A	G1	M	PS
x8	x8	x4	x2



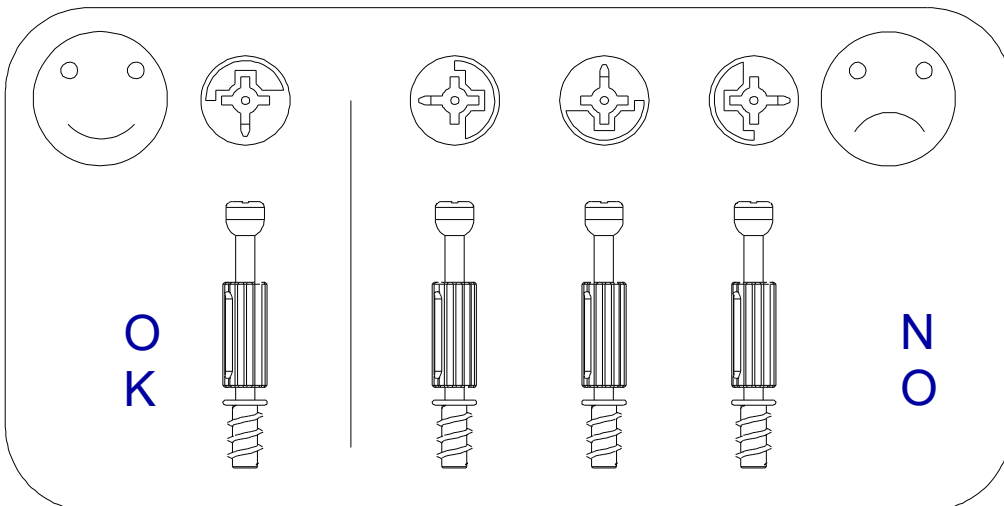
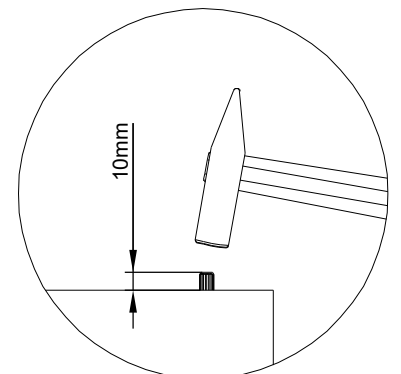
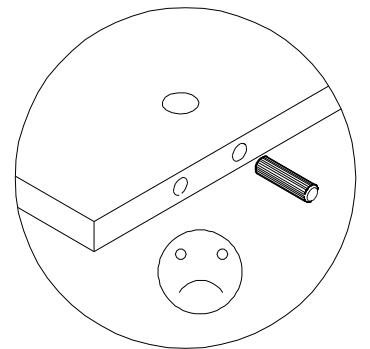

IV-X

 6,3x13				
F2	Z	I	X	MS
x12	x6	x10	x8	x1

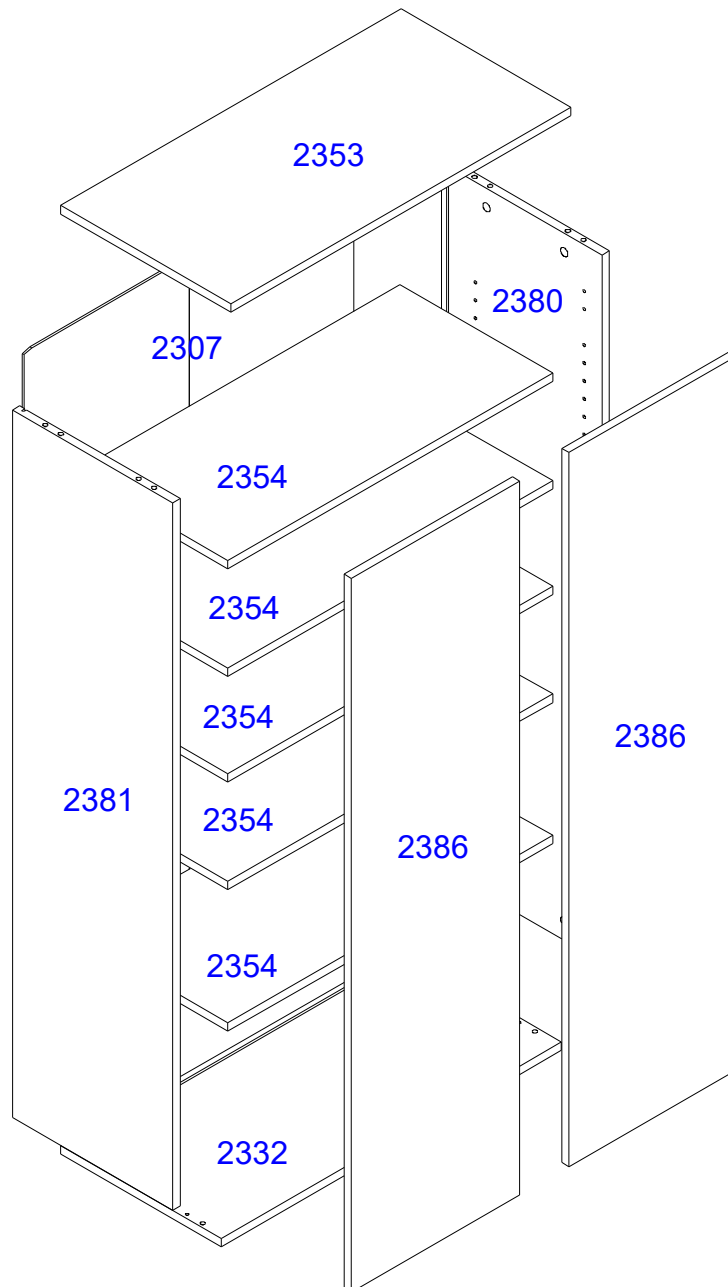
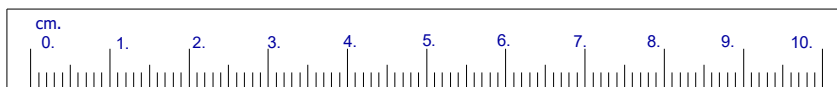
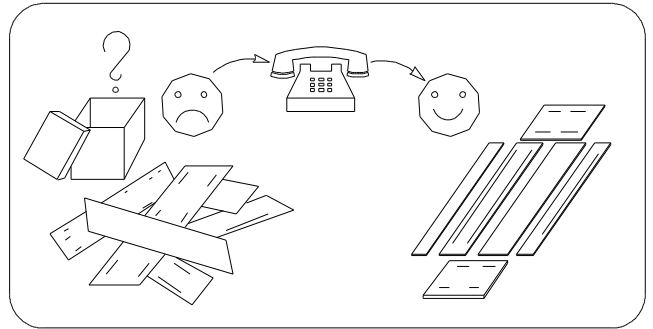
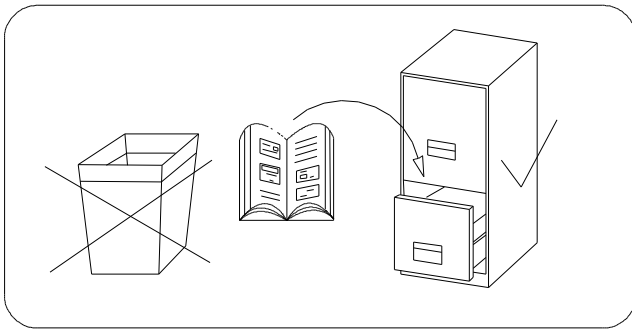



TOKYO Nr20

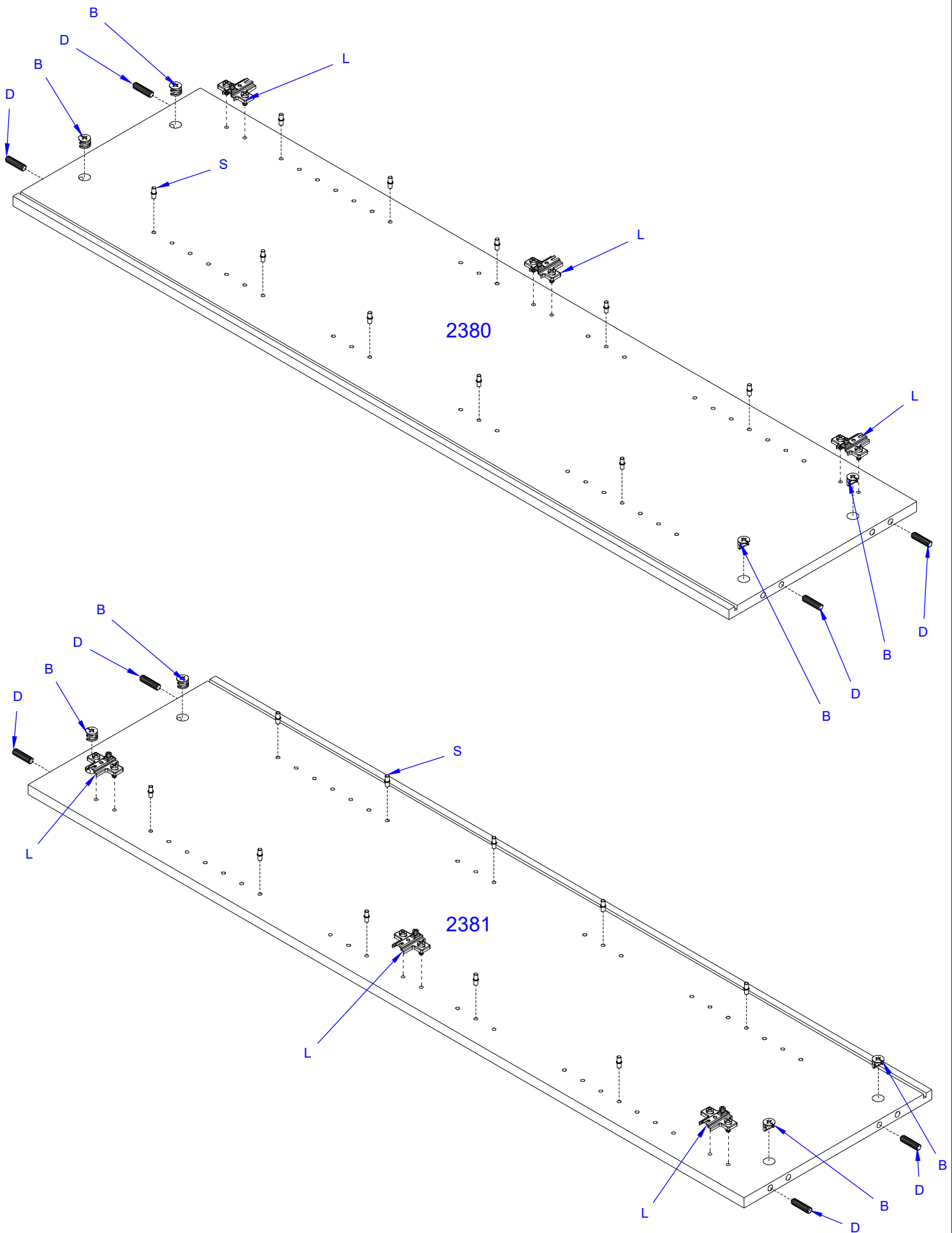

			
B	D	S	L
x8	x8	x20	x6



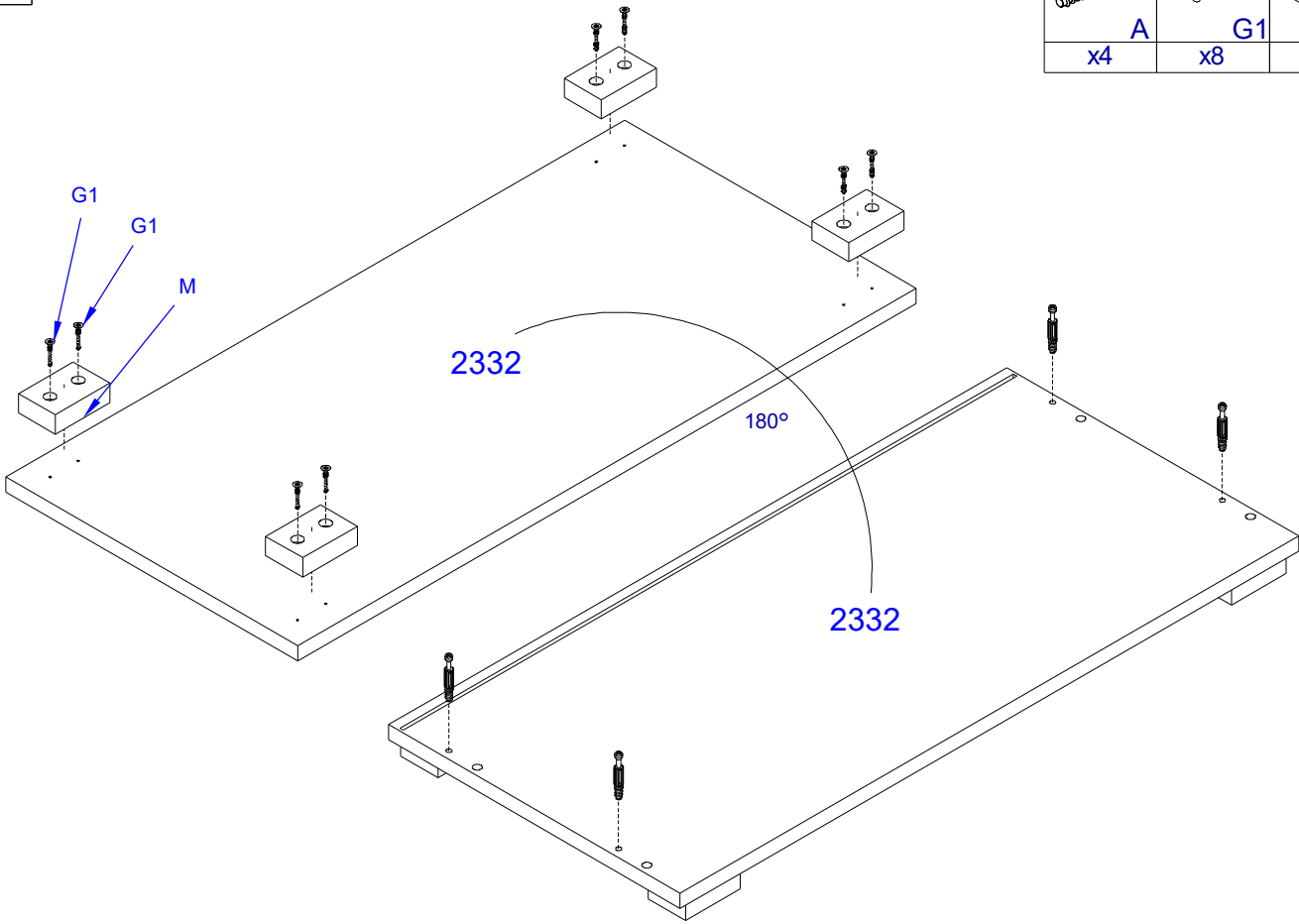

II

	4x25	
A	G1	M
x4	x8	x4



III

	
A	PS
x4	x2

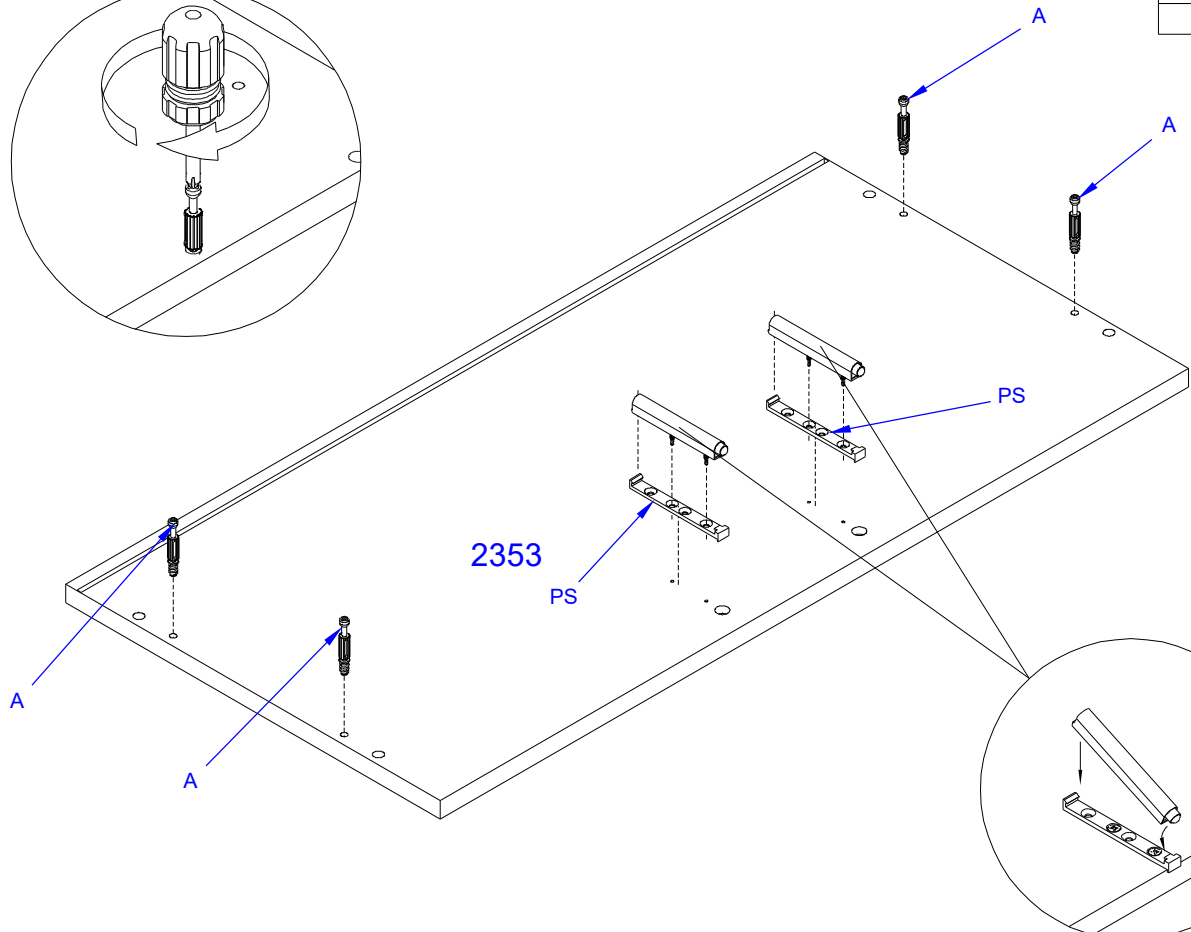
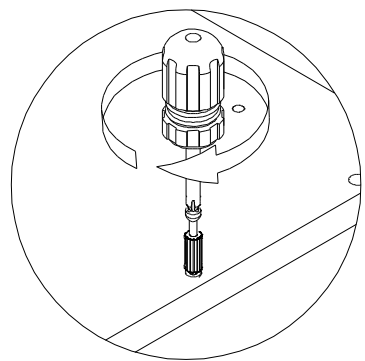

IV

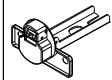
6,3x13		
	F2	Z
x12		x6

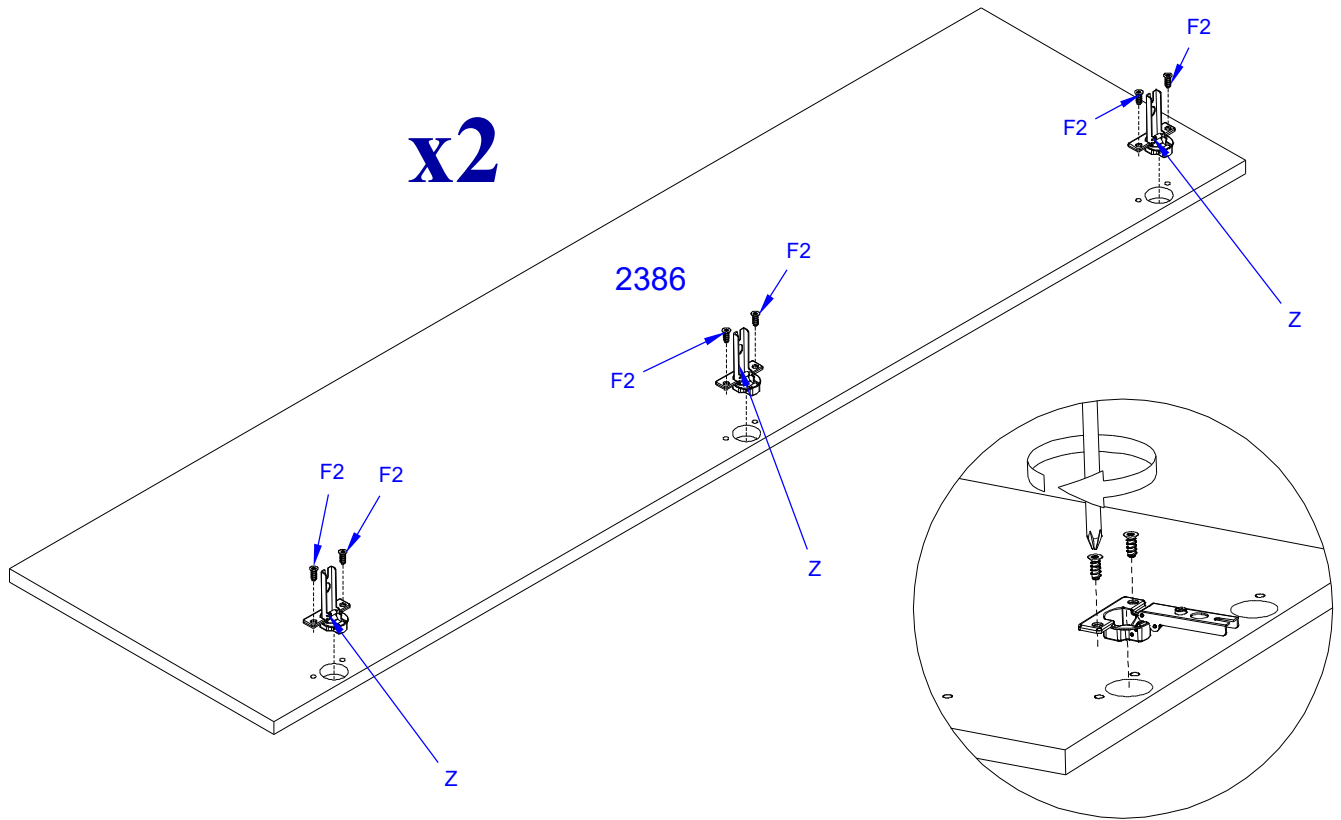

V

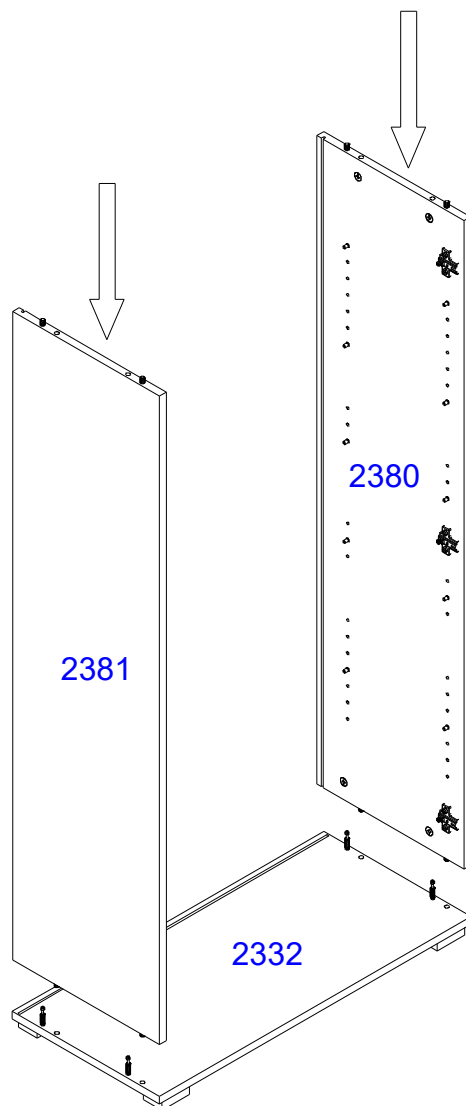
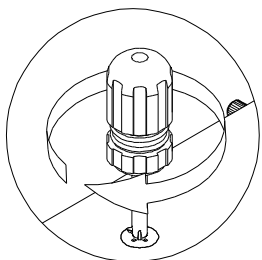

VI

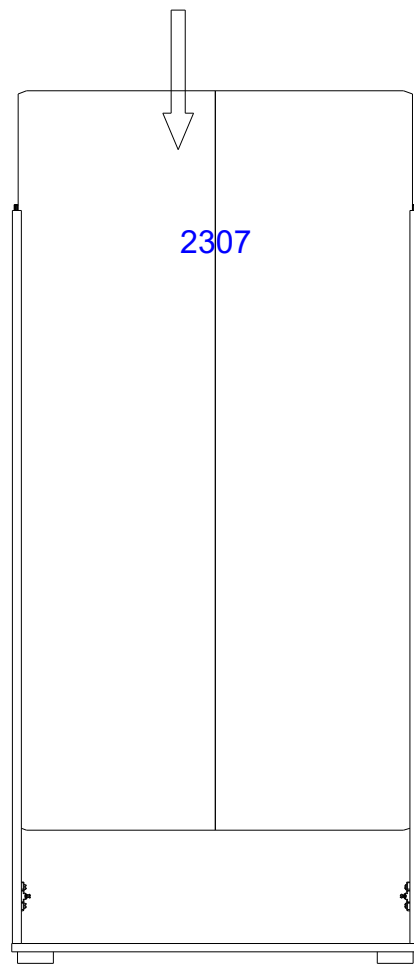
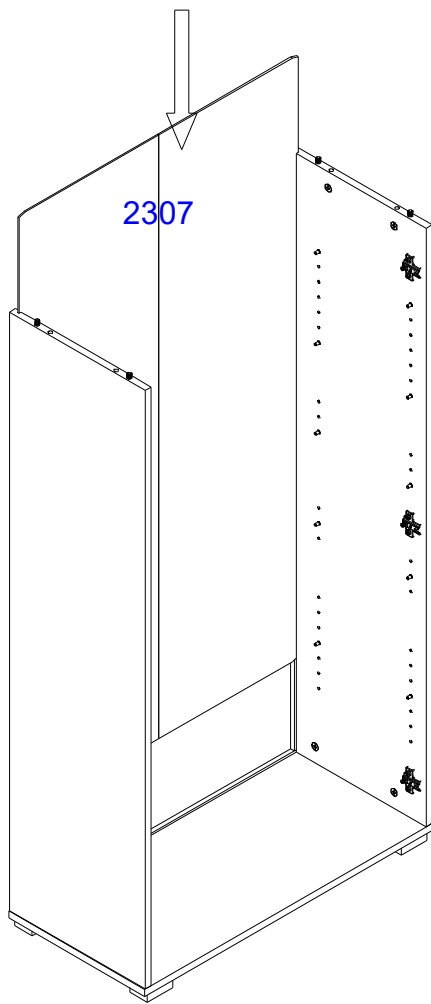

VII

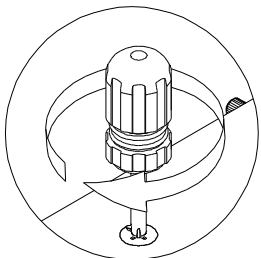
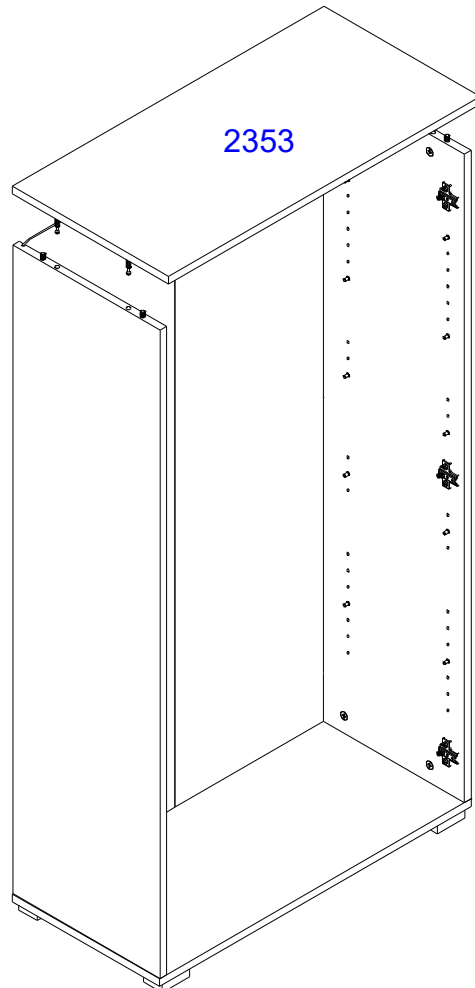

VIII

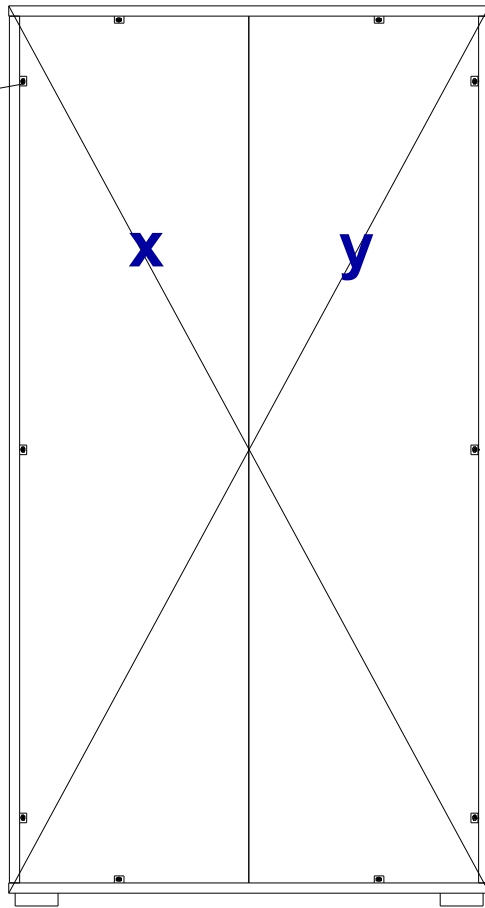
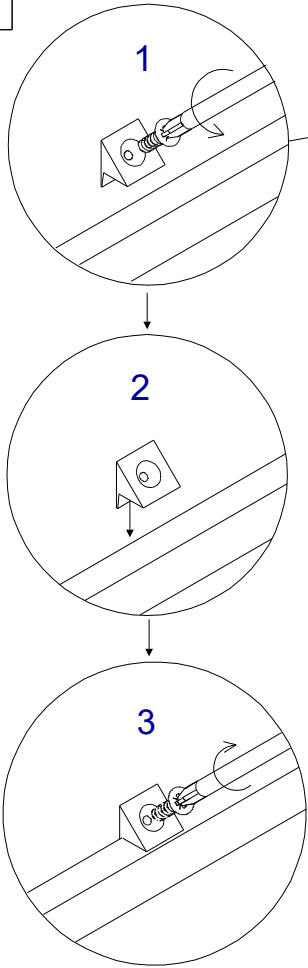

$$x=y$$



I
x10

IX

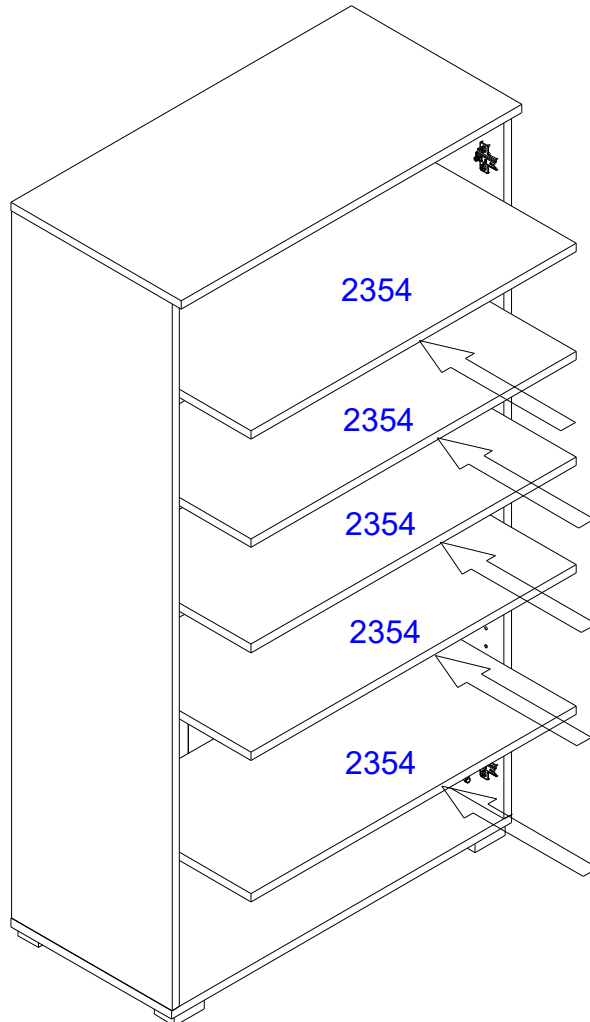

X



X
x8

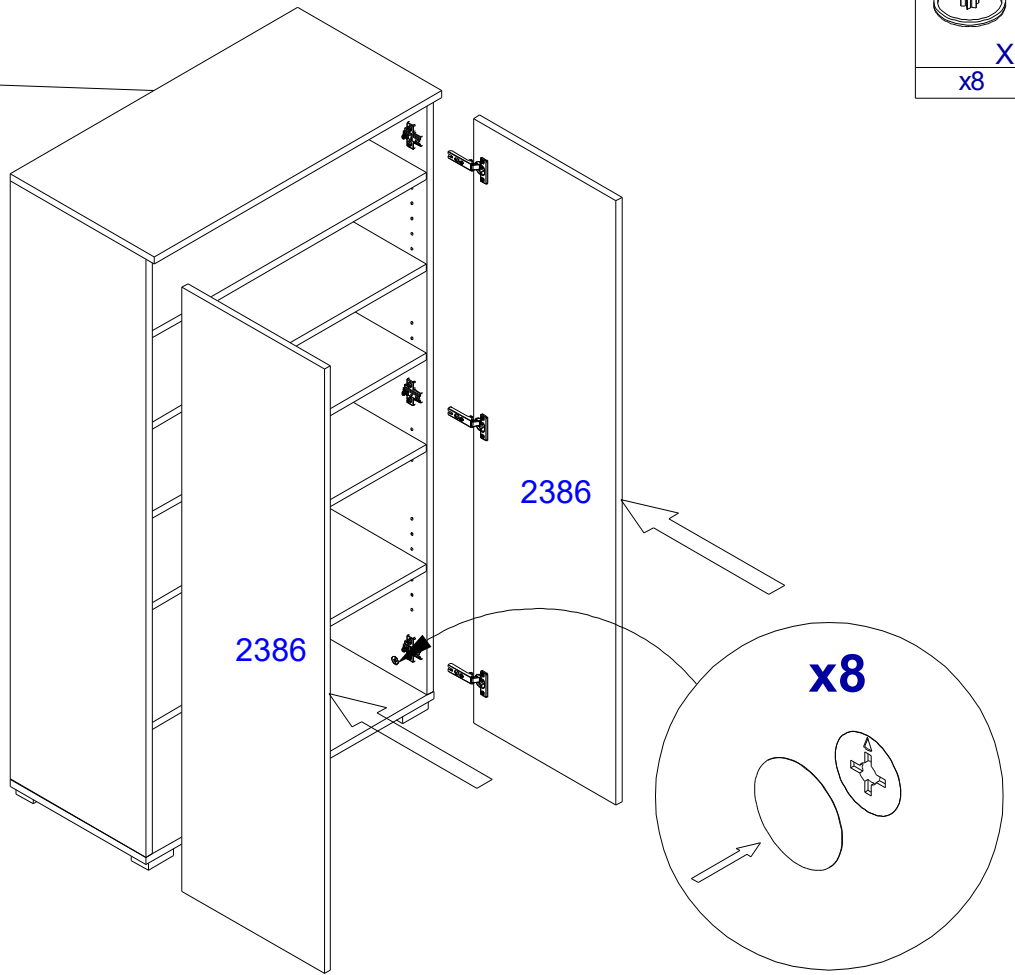
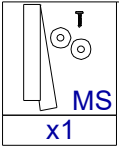

XI

