

Art. Nr. 6385 8166, 1293 7318

LKZ 41164

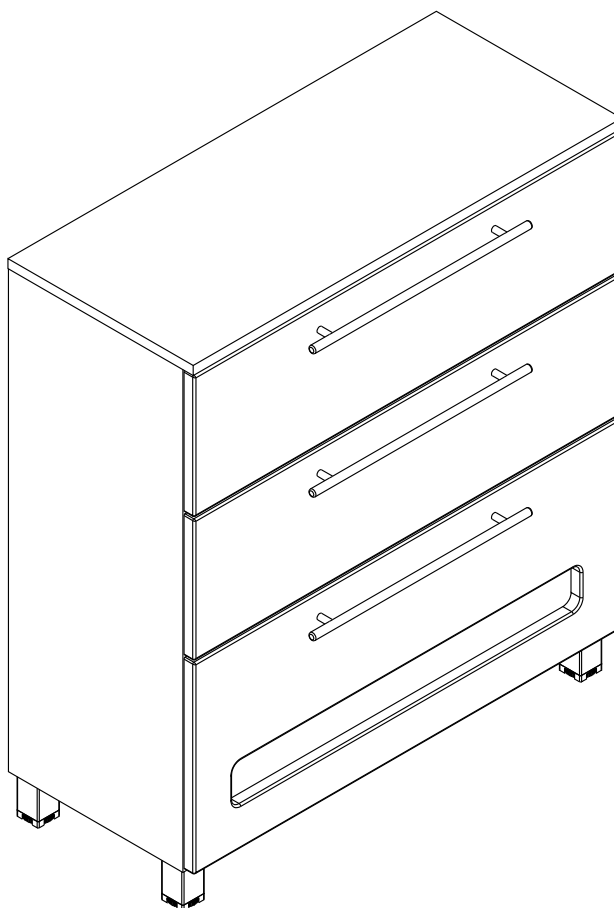

- | | |
|-----------------------------------------|-------------------------------------|
| (D) Montageanleitung | (GB) Assembly instructions |
| (FR) Notice de montage | (IT) Istruzioni di montaggio |
| (NL) Handleiding voor de montage | (PL) Instrukcja montazu |
| (CZ) Montážní návod | (SK) Návod na montáž |
| (HU) Szerelési útmutató | (RO) Instrukțiuni de montaj |
| (TR) Montaj talimati | (RU) Инструкция по монтажу |

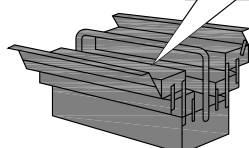
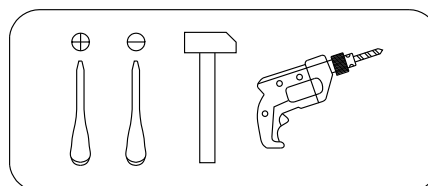

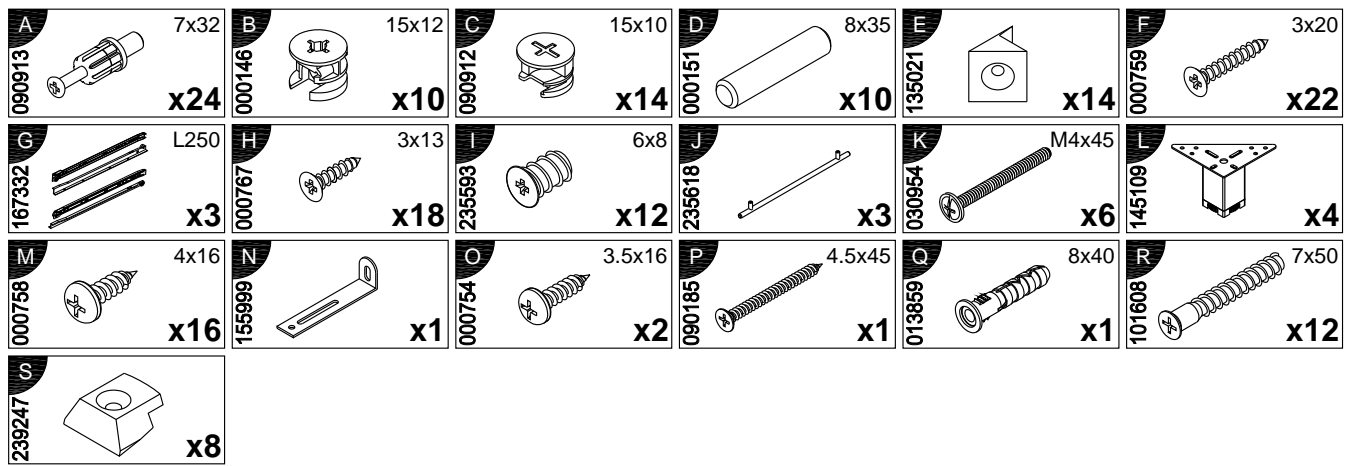
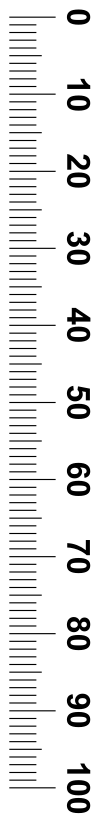

N	Size/MaB (mm)	Qty	✓	N	Size/MaB (mm)	Qty	✓
1	800x320x16	1		11	250x118x12	2	
2	800x320x16	1		12	250x118x12	2	
3	786x340x16	1		13	703x118x12	2	
4	752x319x16	1		14	713x247x3	3	
5	752x80x16	1		15	658x88x4	1	
6	780x224x19	2		16	794x380x3	1	
7	780x336x19	1		17	794x380x3	1	
8	250x170x12	1		18	L=758	1	
9	250x170x12	1					
10	703x170x12	1					

Service - Dienstverlening - Serwis - Servis - Сервисная служба



Name - Naam - Nazwa - Isim - Название

Nr. - No. - Номер

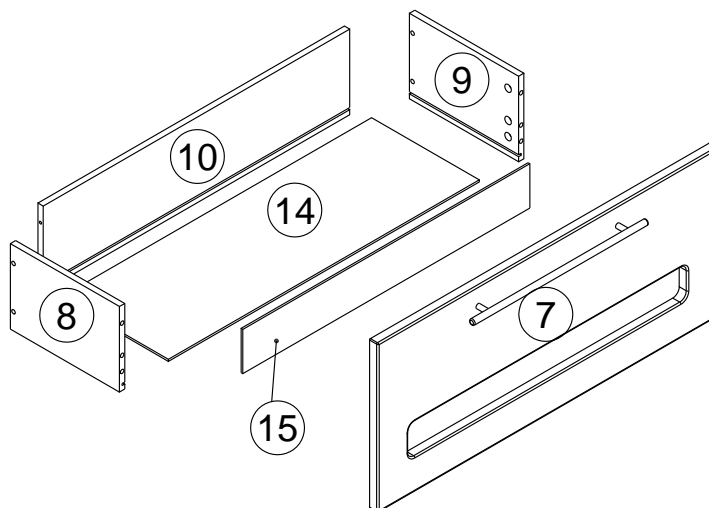
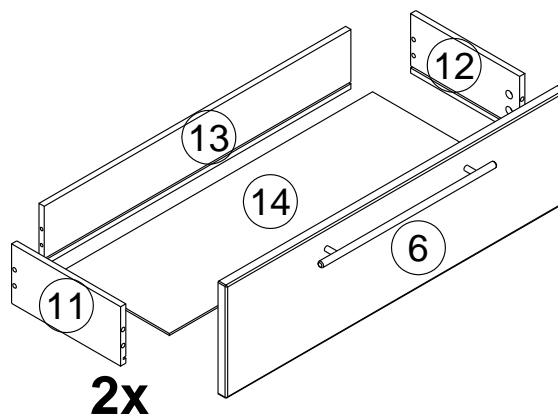
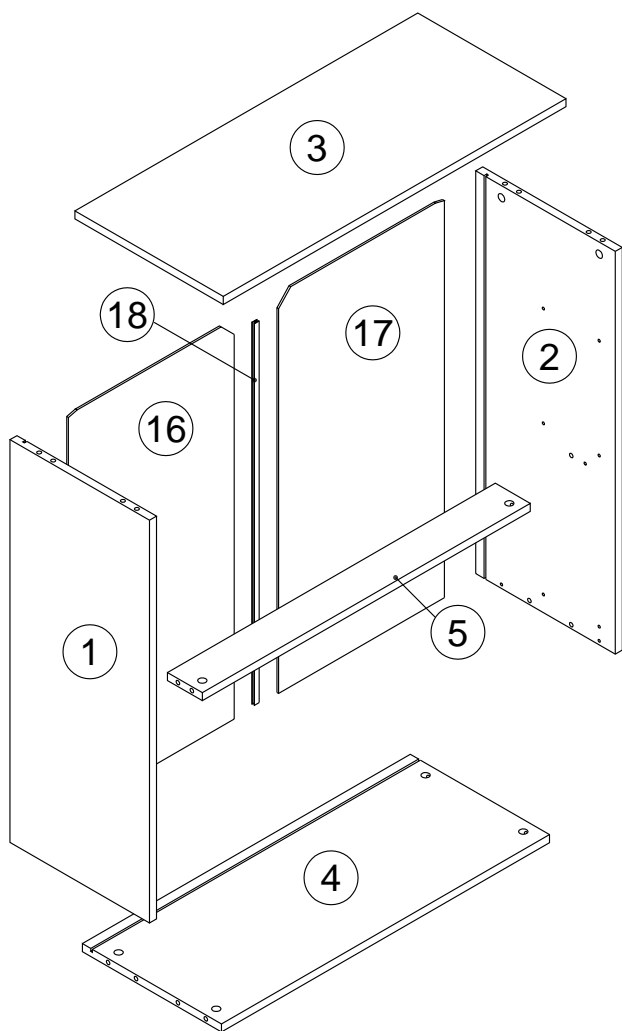
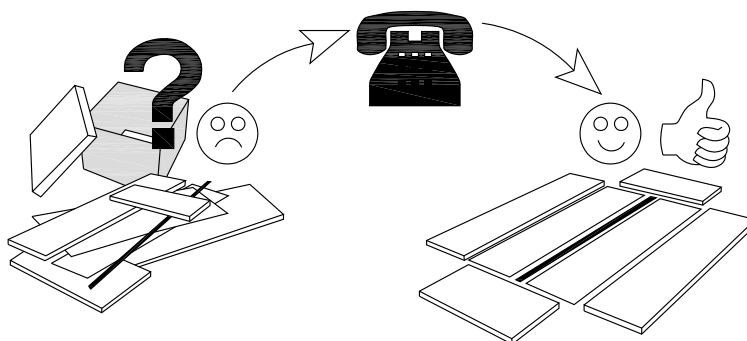
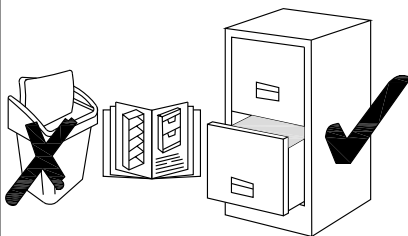

Typ - Type - Тип - Тип

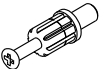

1

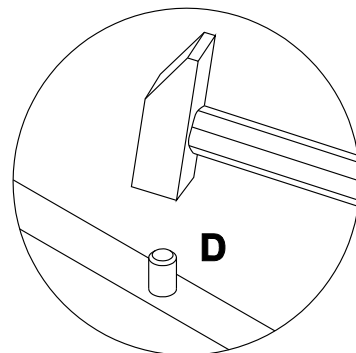
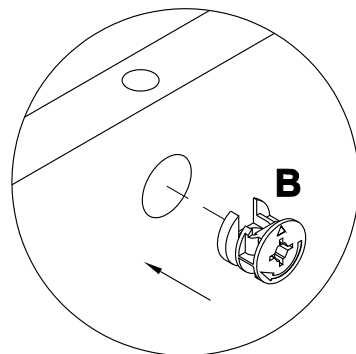
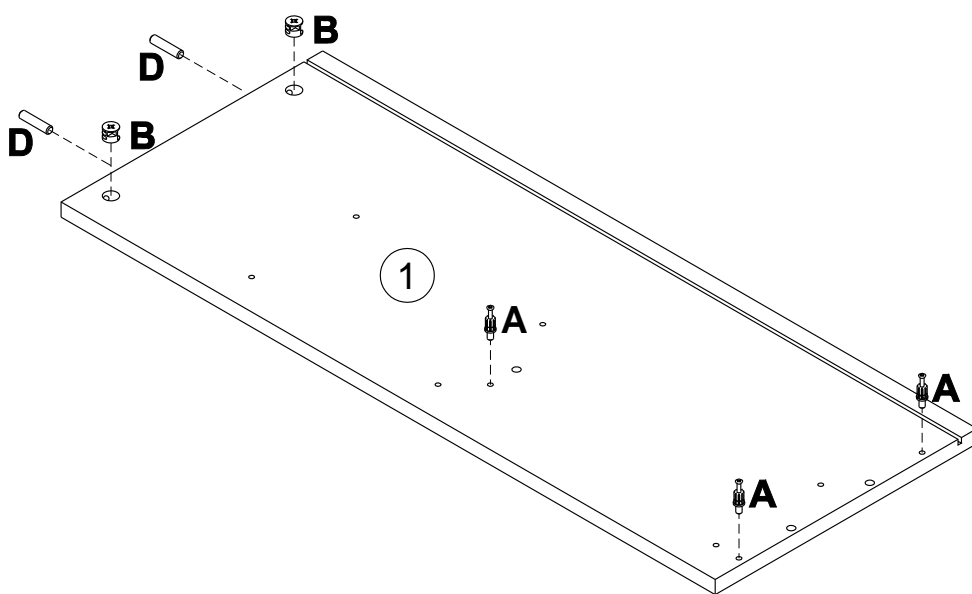
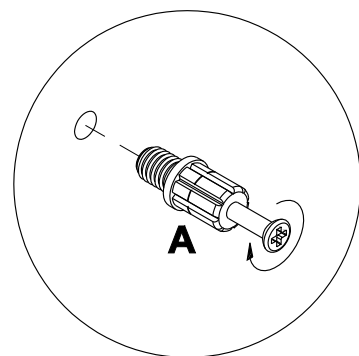
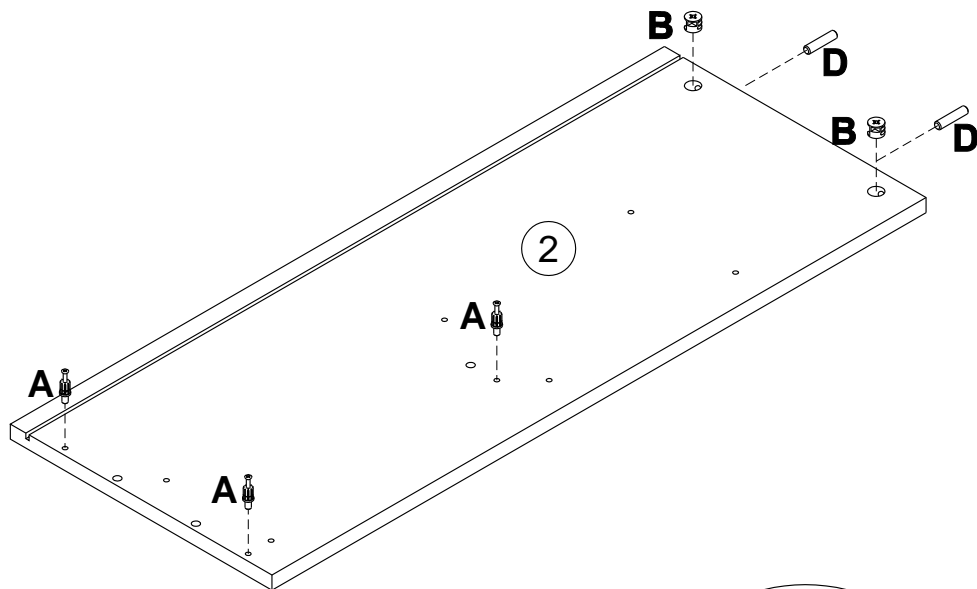
A 090913		7x32	B 000146		15x12	D 000151		8x35
		x6			x4			x4



<p>G</p>  <p>L250</p> <p>x3</p>	<p>H</p>  <p>3x13</p> <p>x6</p>	<p>I</p>  <p>6x8</p> <p>x12</p>
-------------------------------------------------------------------------------------------------------------------------------	--------------------------------------------------------------------------------------------------------------------------------	--------------------------------------------------------------------------------------------------------------------------------

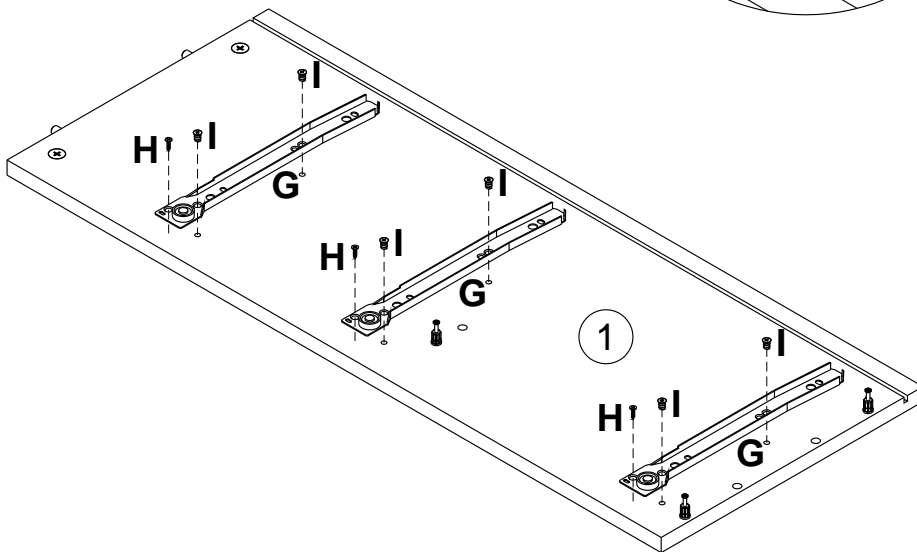
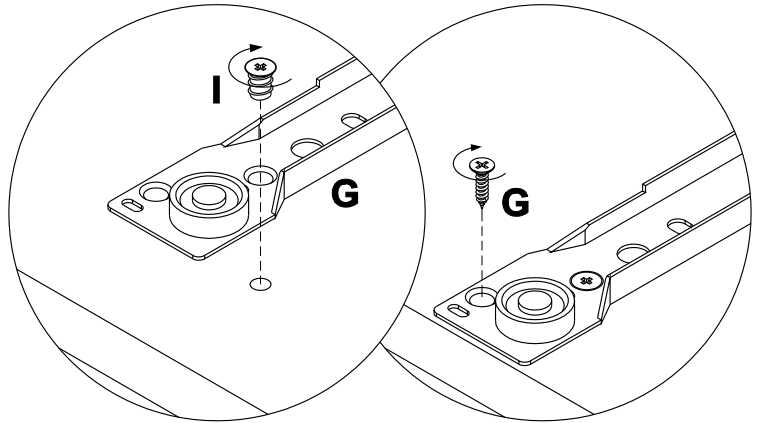
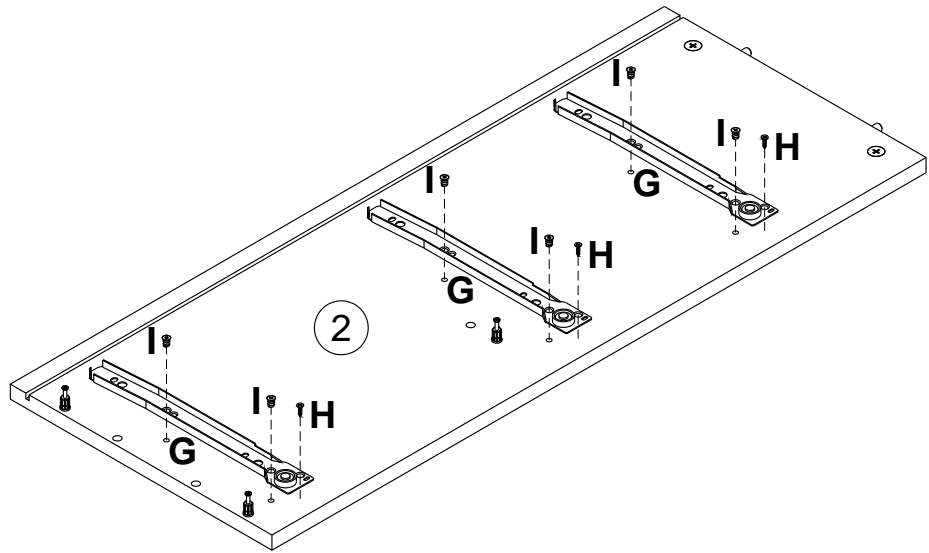

3

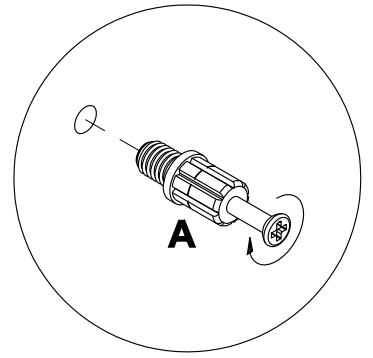
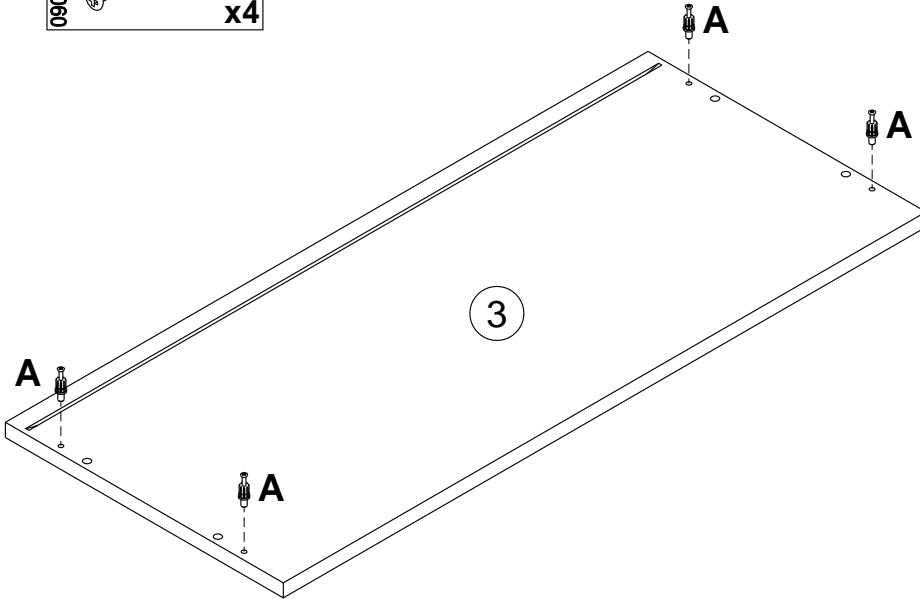
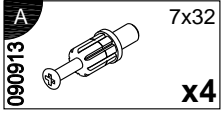



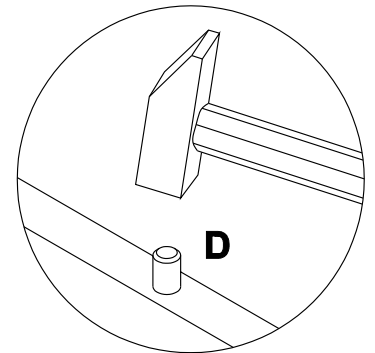
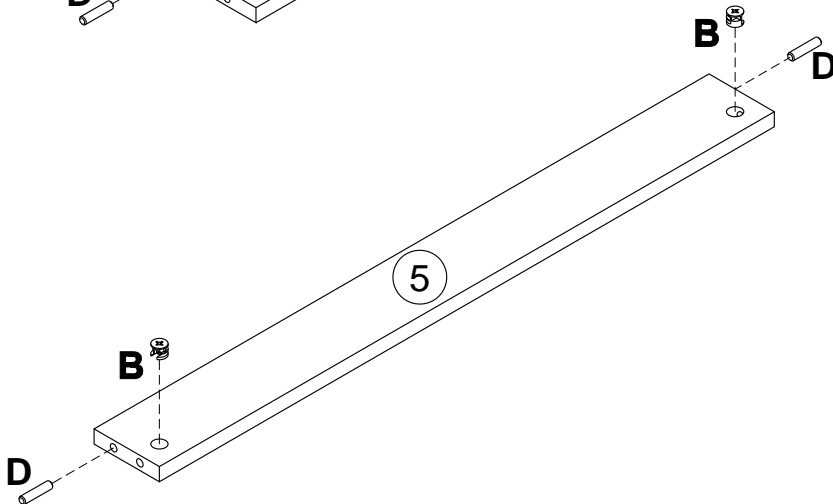
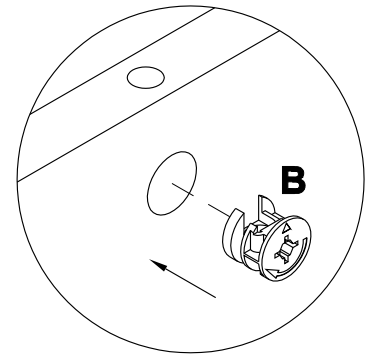
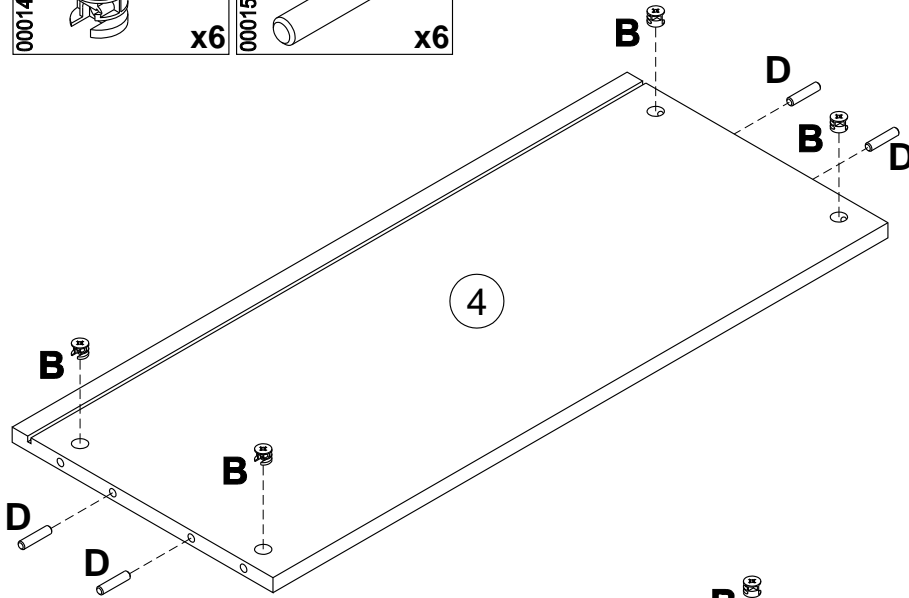
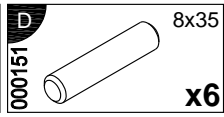
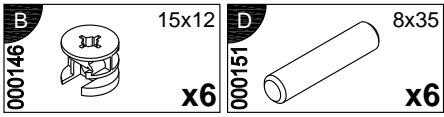

4



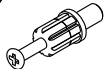

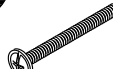
6

5

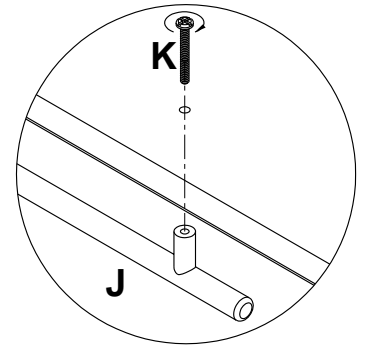
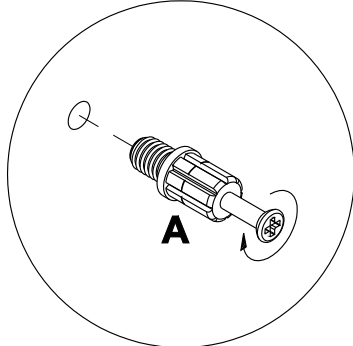
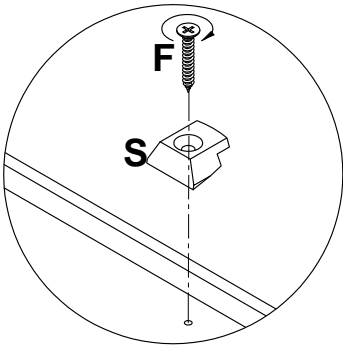
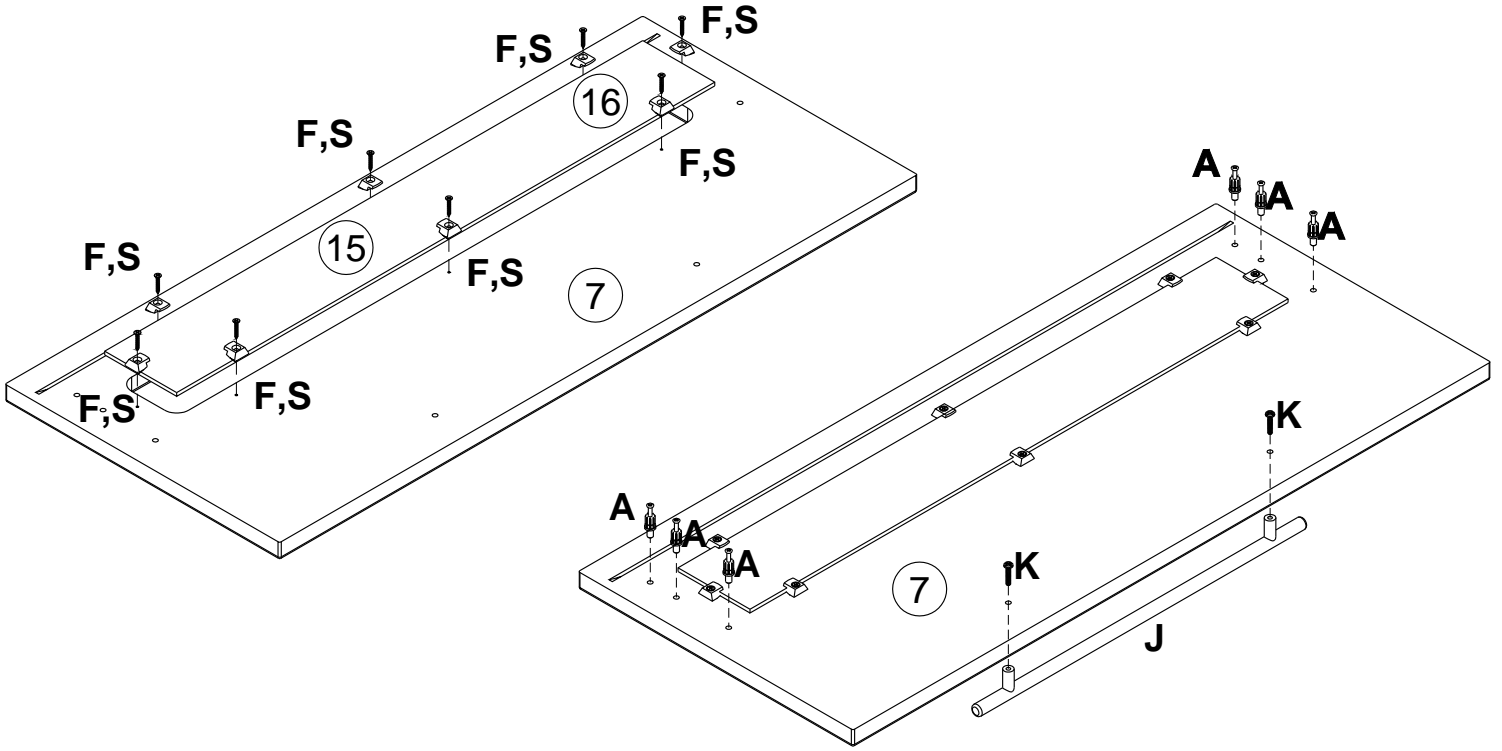
A	090913		7x32	F	000759		3x20	J	235618		x1	K	030954		M4x45	S	239247		x8
			x6				x8								x2				



6

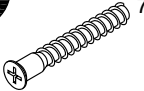

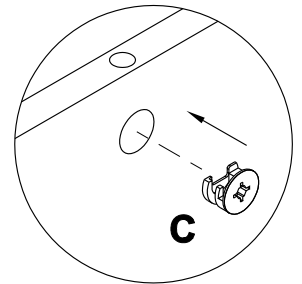
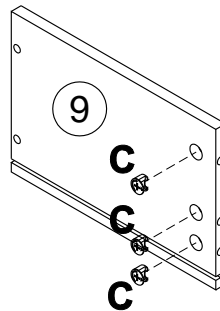
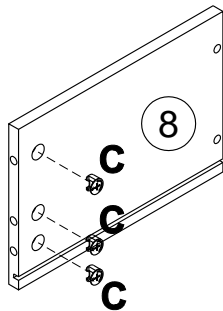
C	090912		15x10	G	167332		L250	H	000767		3x13	R	101608		7x50
			x6				x1				x4				x4

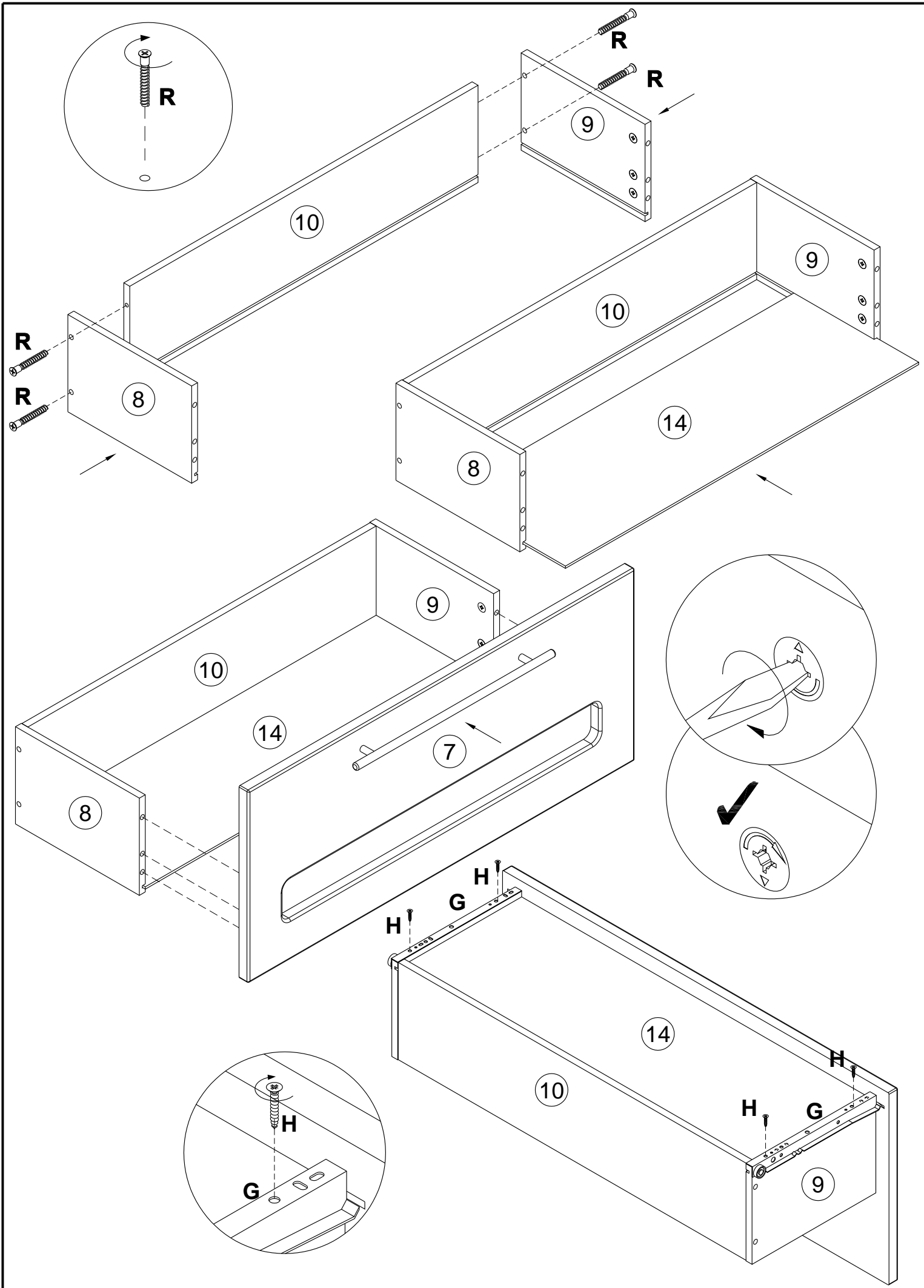

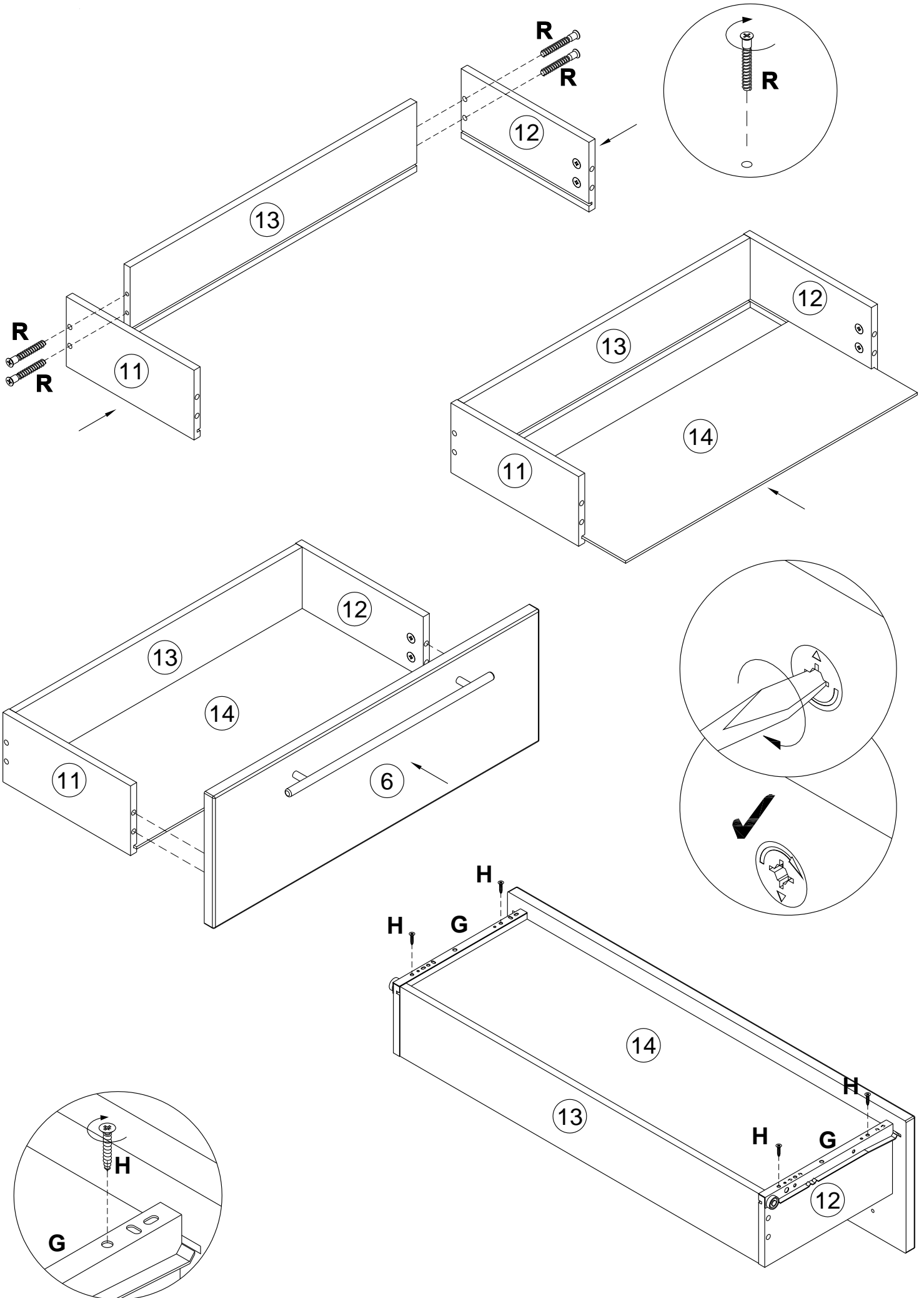



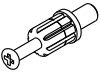

7

A	090913		7x32	J	235618		x2	K	030954	M4x45	x4
----------	--------	-----------------------------------------------------------------------------------	------	----------	--------	-----------------------------------------------------------------------------------	----	----------	--------	-------	----

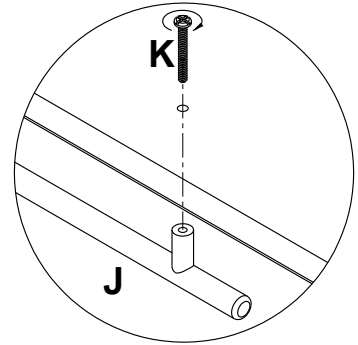
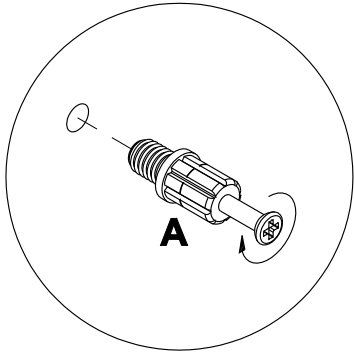
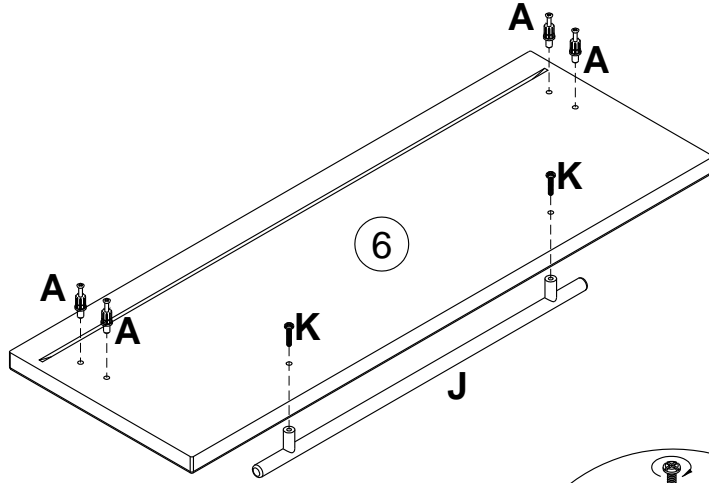
2x

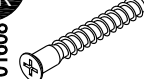

8

C	090912		15x10	G	167332		L250	H	000767	3x13	x8	R	101608		7x50	x8
----------	--------	-------------------------------------------------------------------------------------	-------	----------	--------	-------------------------------------------------------------------------------------	------	----------	--------	------	----	----------	--------	--------------------------------------------------------------------------------------	------	----

2x

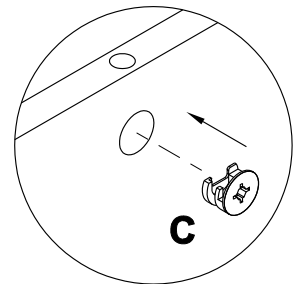
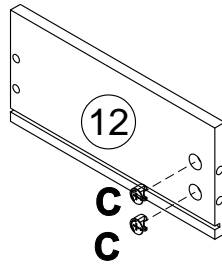
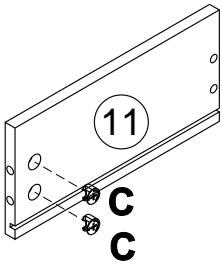

9

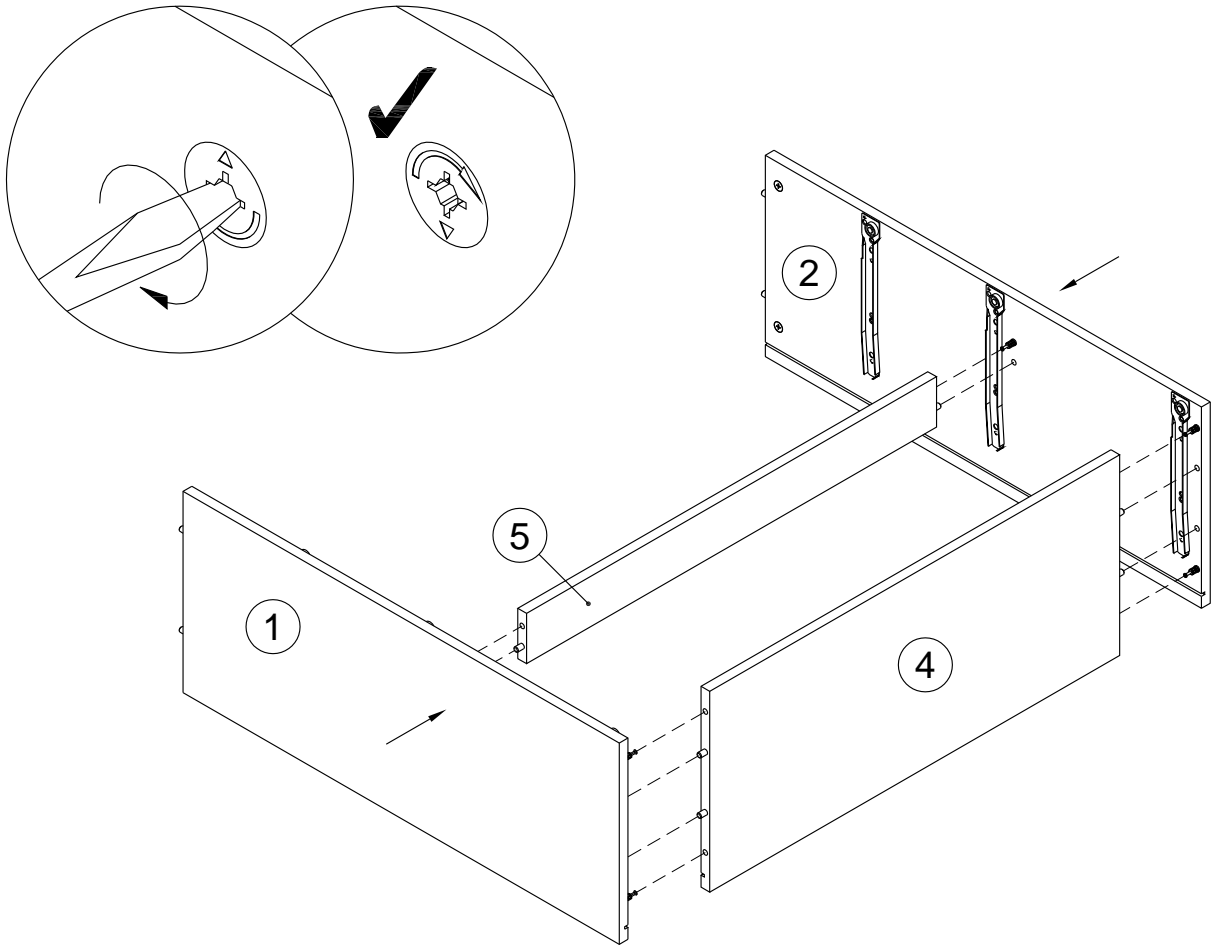

10

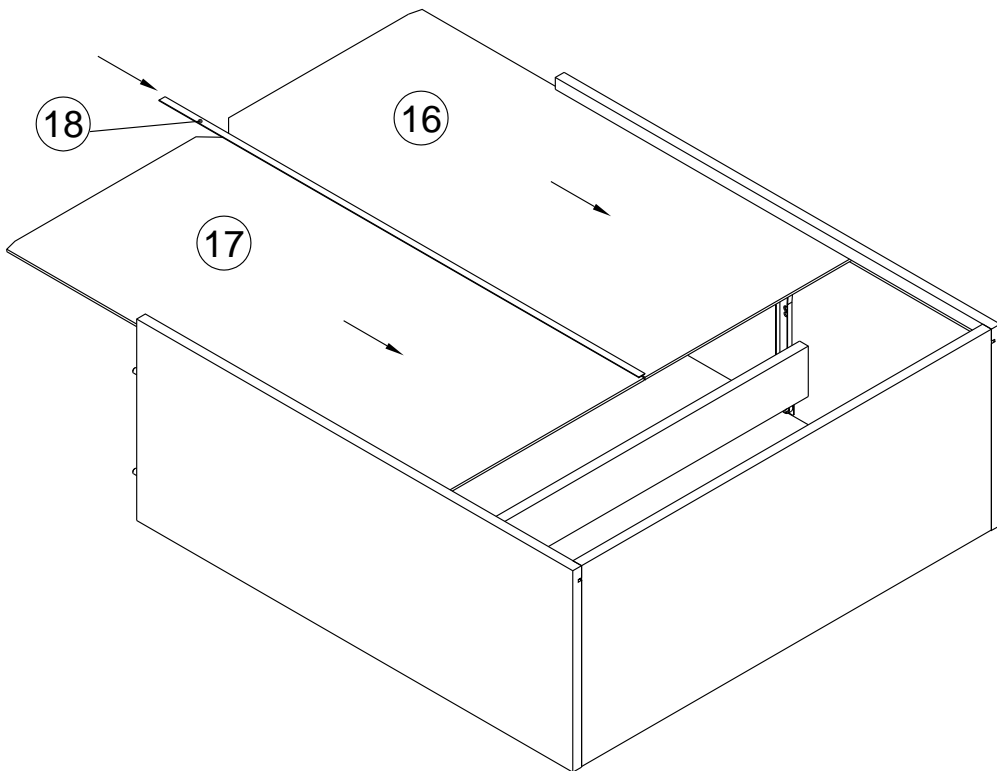

11

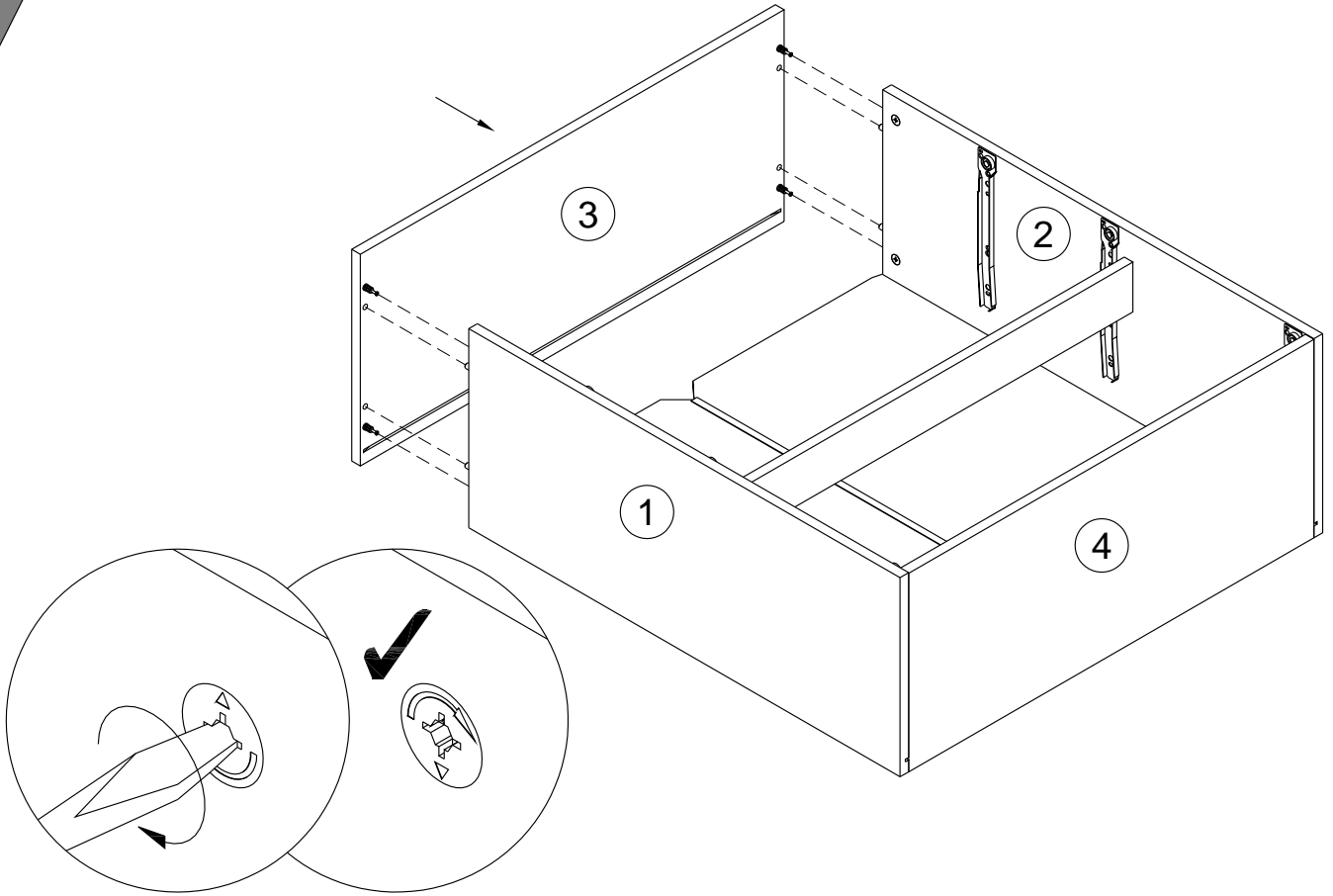

12

135021



x14

000759



3x20
x14

$L1=L2$

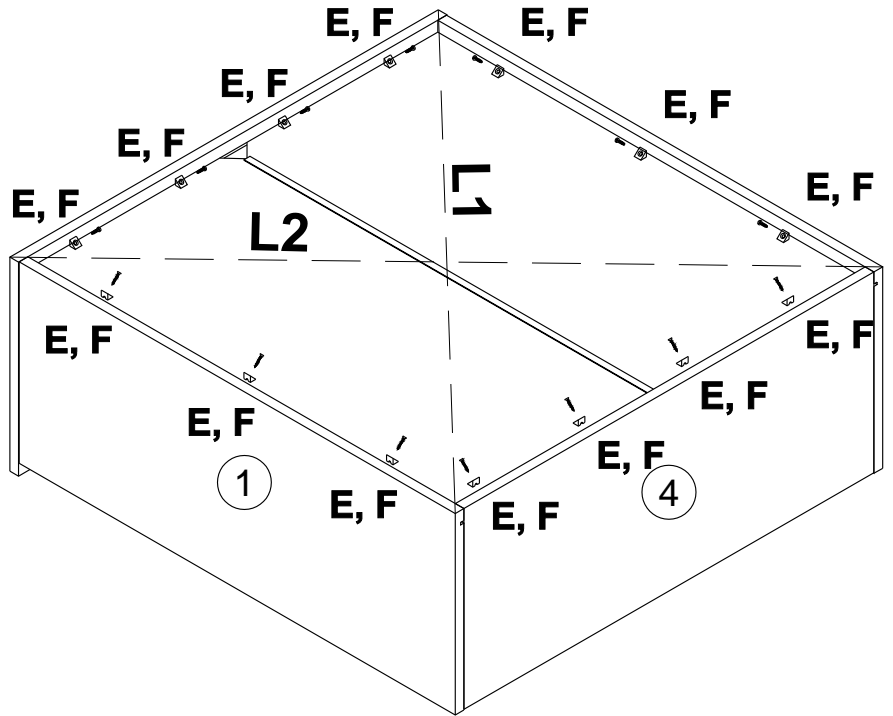
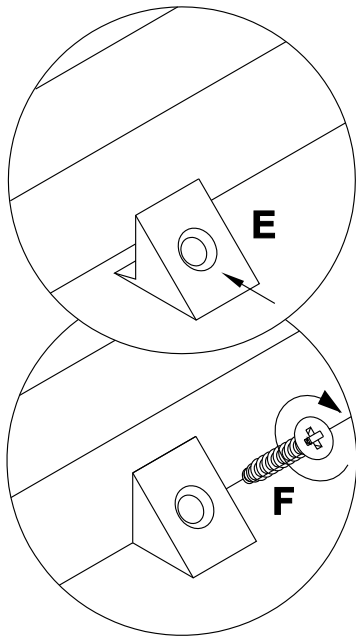

13

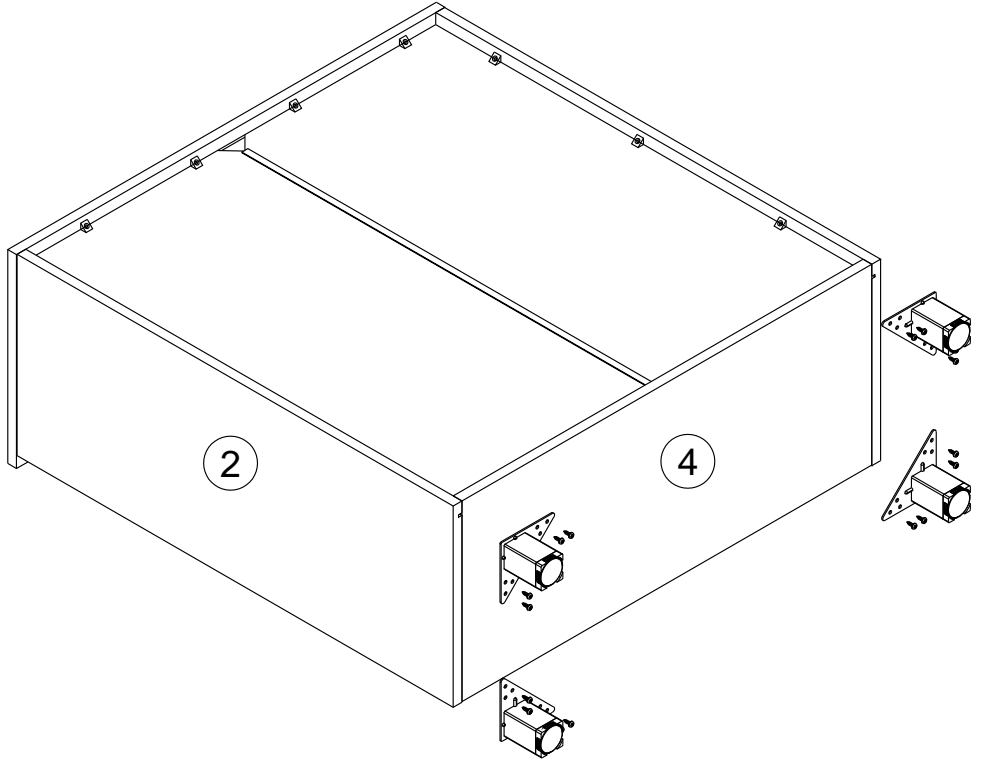
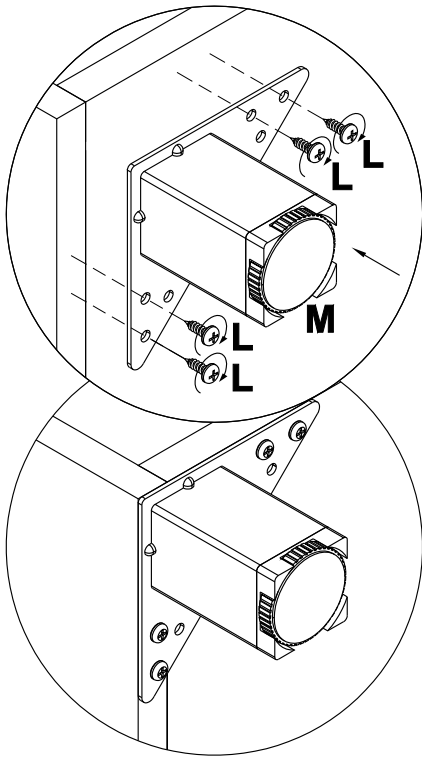
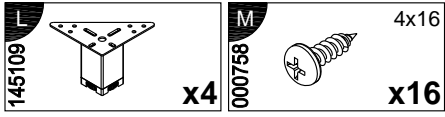

14

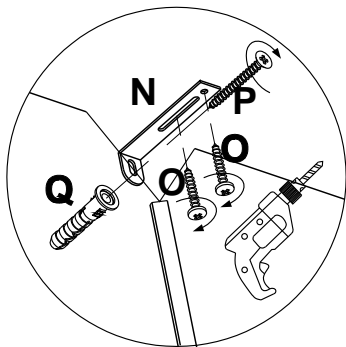
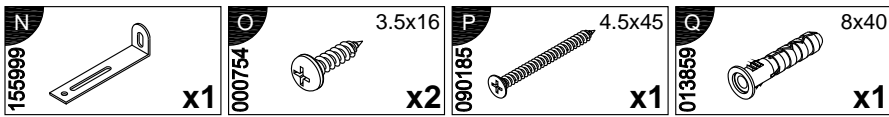

N, O, P, Q

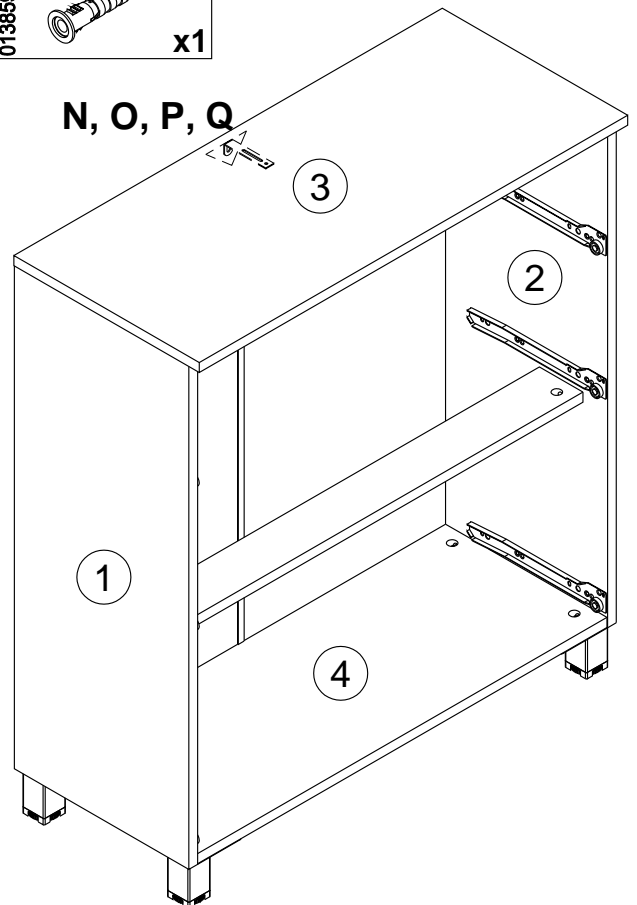

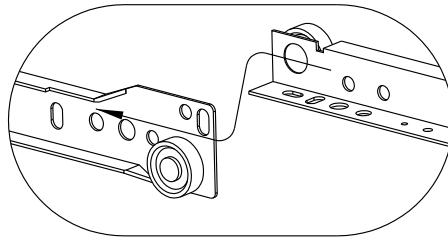
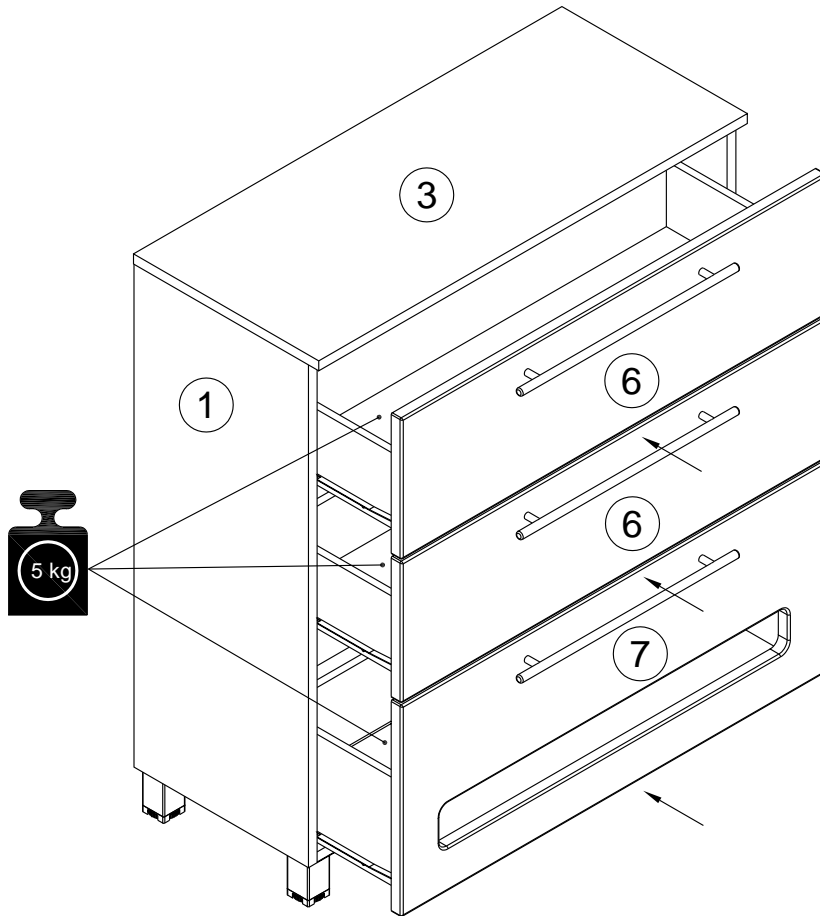

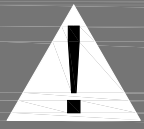

Achtung • Attention • Attenzione
Opgelet • Uwaga • Pozor • Figyelem
Atenție • Dikkat • Внимание

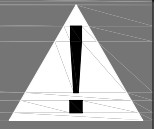

(D)	Wandbefestigung dient als Kippschutz – unbedingt anbringen! Bei einigen Wandtypen kann ein Spezialdübel erforderlich sein!
(GB)	The wall fastening serves to prevent tipping – be absolutely sure to mount it! For certain wall types, a special wall plug may be necessary!
(FR)	La fixation murale sert de protection contre le basculement – à installer impérativement ! Pour certains types de murs il faut des chevilles spéciales !
(IT)	Il fissaggio alla parete serve da protezione anti-ribaltamento – attaccarla assolutamente ! Per alcune strutture di parete può essere necessario un tassello speciale !
(NL)	Bevestiging aan de muur dient als kantelbescherming – zeker en vast bevestigen ! Bij enkele muurtypes is een speciale plug misschien vereist !
(PL)	Mocowanie do ściany jest jednocześnie zabezpieczeniem przed przewróceniem – koniecznie zamontować! Do niektórych rodzajów ścian koniecznie zastosować specjalne kołki mocujące.
(CZ)	Montáž na stěnu slouží jako ochrana proti převrnutí – bezpodmienečně umístěte! U některých typů stěn může být zapotřebí speciální hmoždinka !
(SK)	Upevnenie na stenu slúži ako ochrana proti prevráteniu – bezpodmienečne použite! Pre niektoré druhy stien môže byť potrebná špeciálna hmoždenka !
(HU)	A terméket a falhoz kel rögzíteni, különben az felborulhat! Egyes faltípusoknál speciális tiplit kell használni !
(RO)	Sistemul de fixare la perete servește ca protecție la răsturnare – de montat obligatoriu! Pentru unele tipuri de pereți este posibil să fie necesar un diblu special !
(TR)	Duvardaki sabitleme, devrilmeye karşı bir emniyet tedbiridir ve mutlaka monte edilmelidir! Bazı duvar tiplerinde bunun için özel bir dübel gerekli olabilir !
(RU)	Обязательно установите крепление на стене во избежание опрокидывания ! Для некоторых типов стен может потребоваться специальный дюбель !