

101	16		407	8		M6 x 70 mm
112	6		715	1		
124	12		733	8		
190	4		743	4		
204	1		814	1		
310	4					

Ø8 x 30 mm

M4 x 10 mm

ACHTUNG: Flansche Mattensicherer 100 mm
 ATTENTION: L'espacement maximum de supports de 100 mm
 ATTENZIONE: Flansche materassi 100 mm
 ATTENÇÃO: Flanscos thickness of mattress 100 mm
 Especifica des Sicherheitsbestimmungen DIN EN 216-1

 WIMEX
 WIMEX
 WIMEX

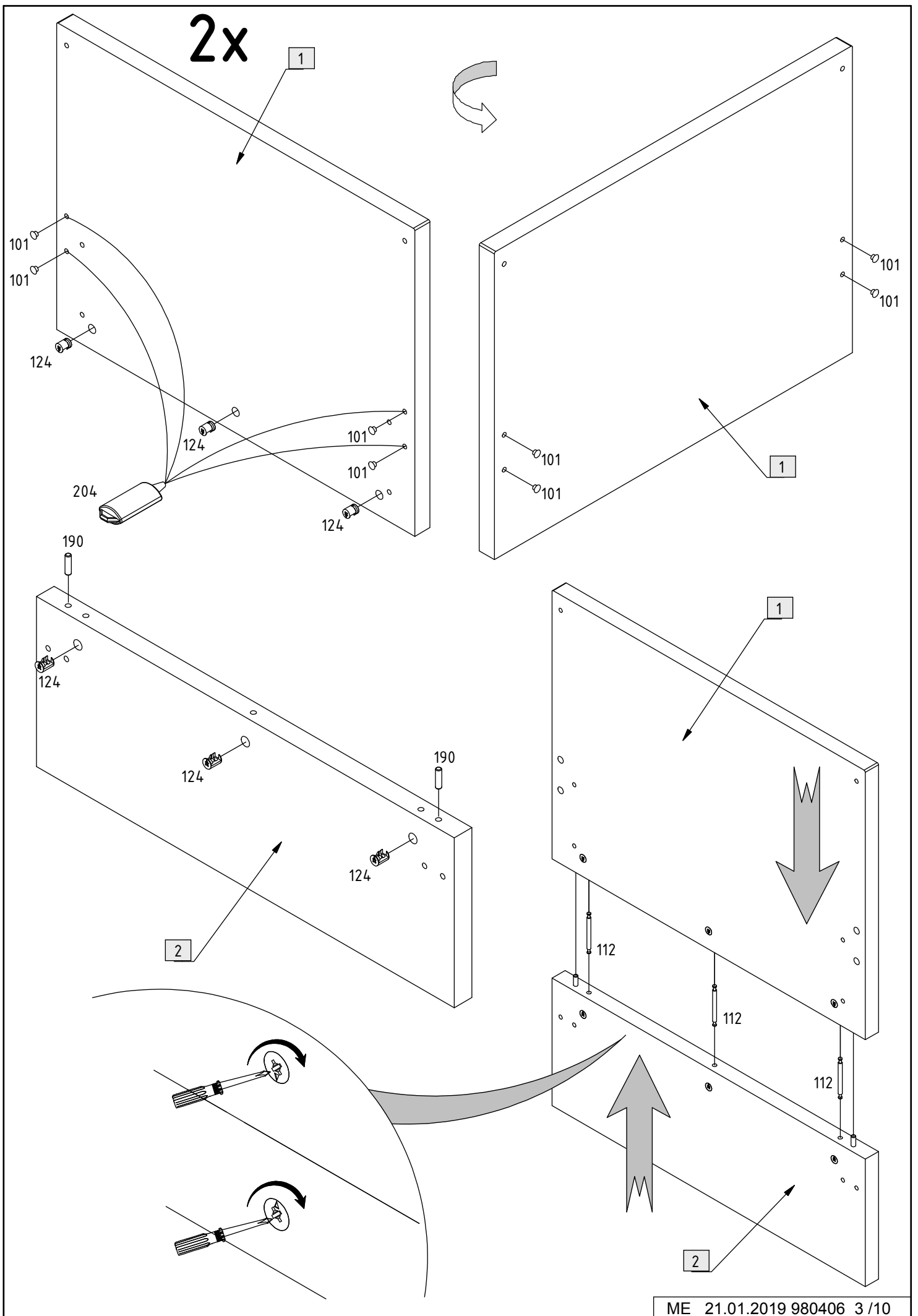

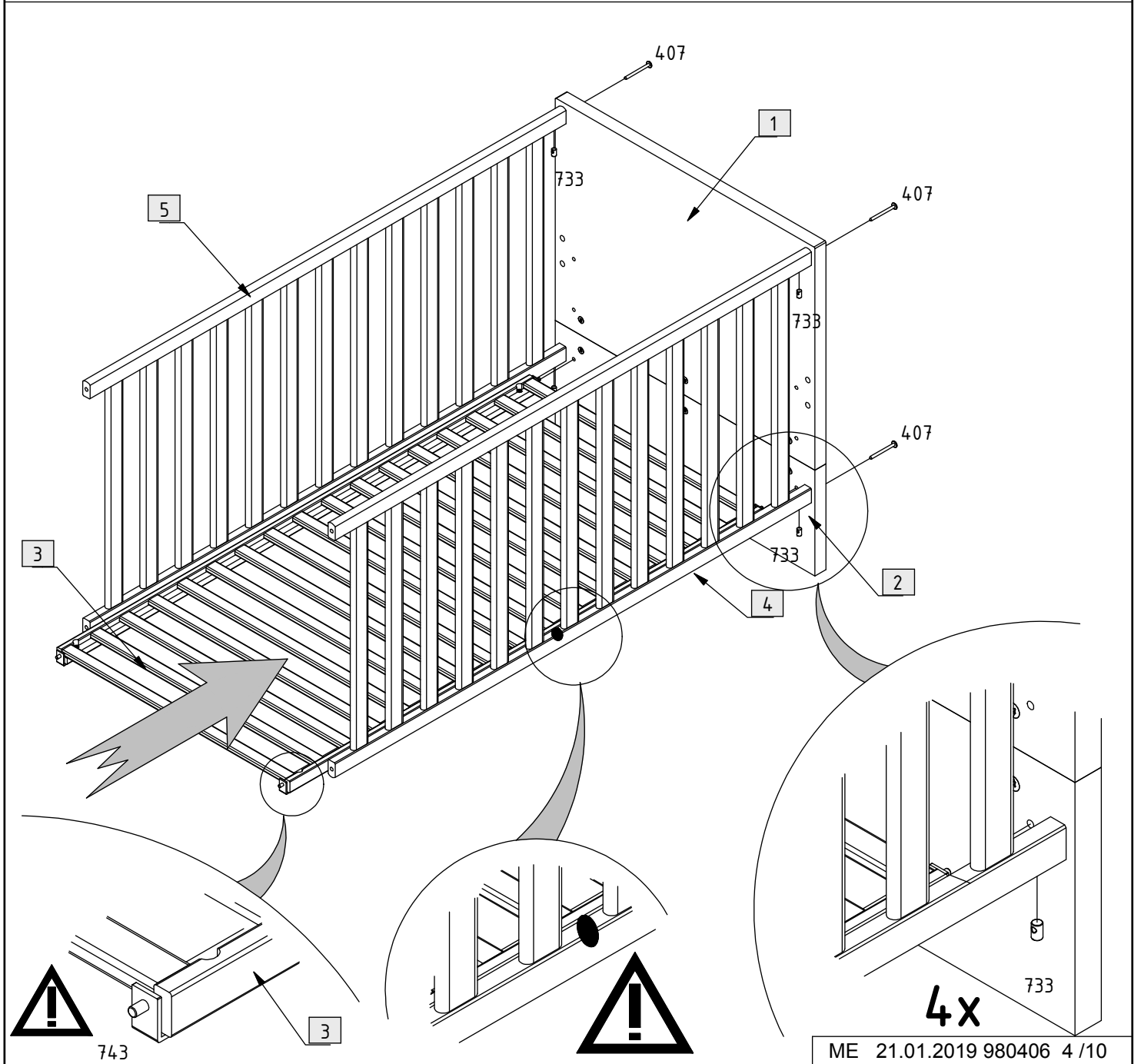
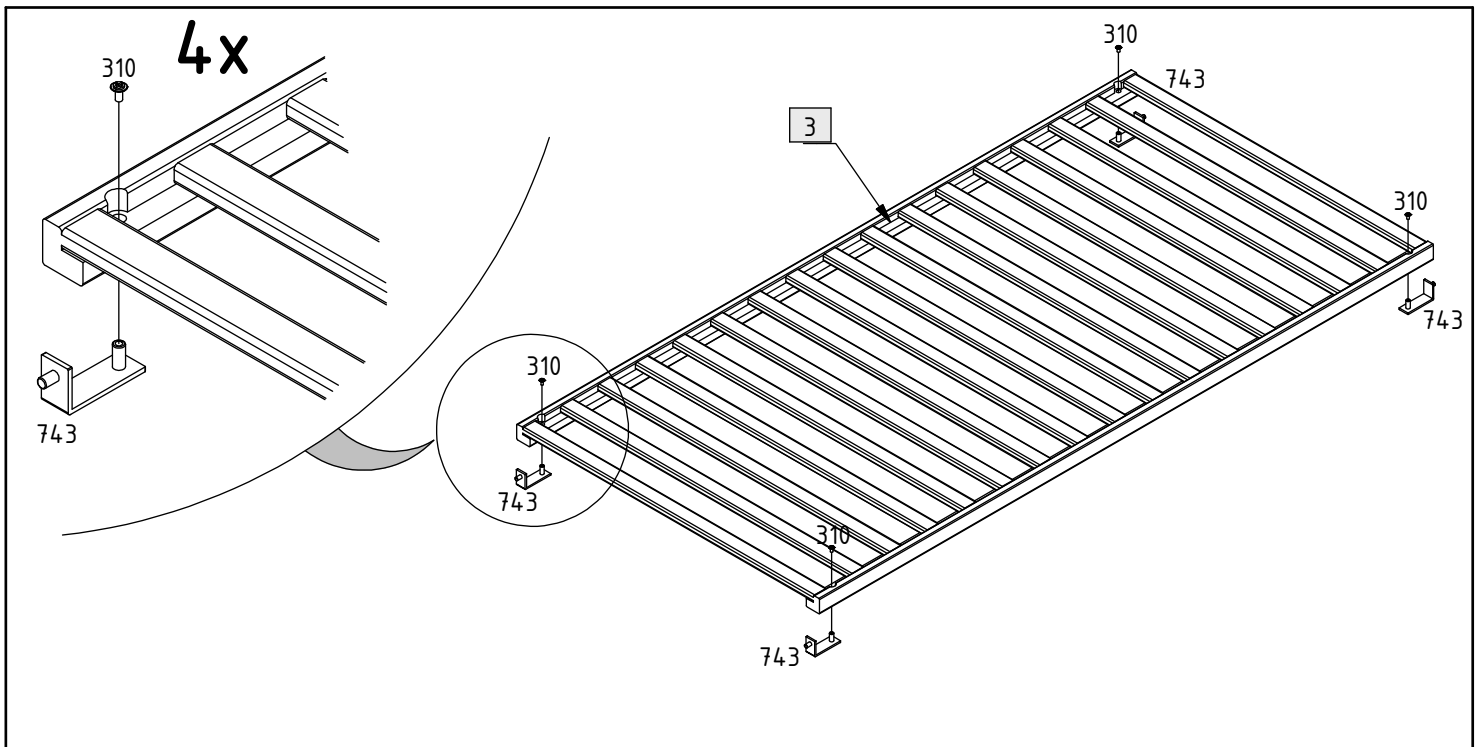

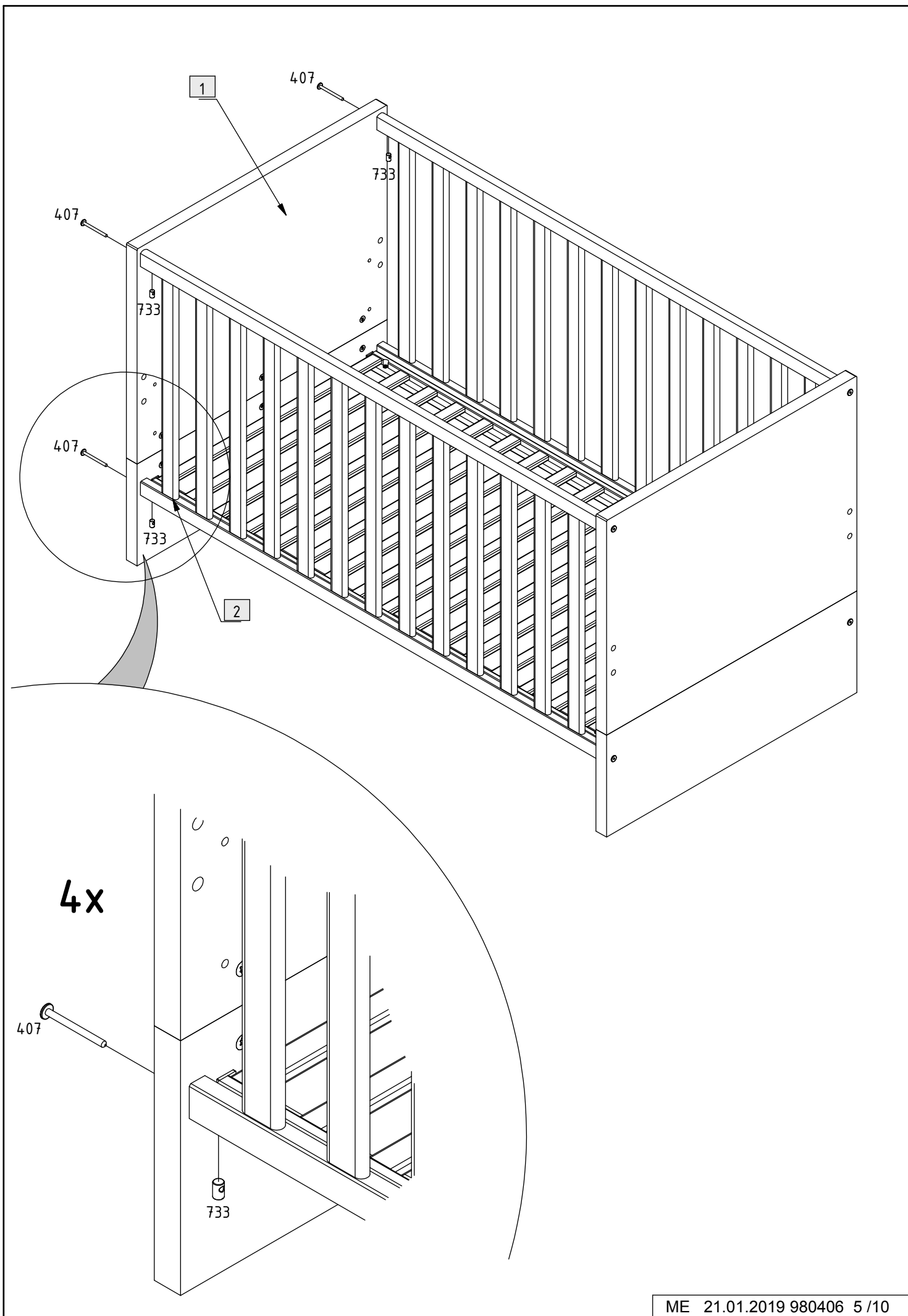

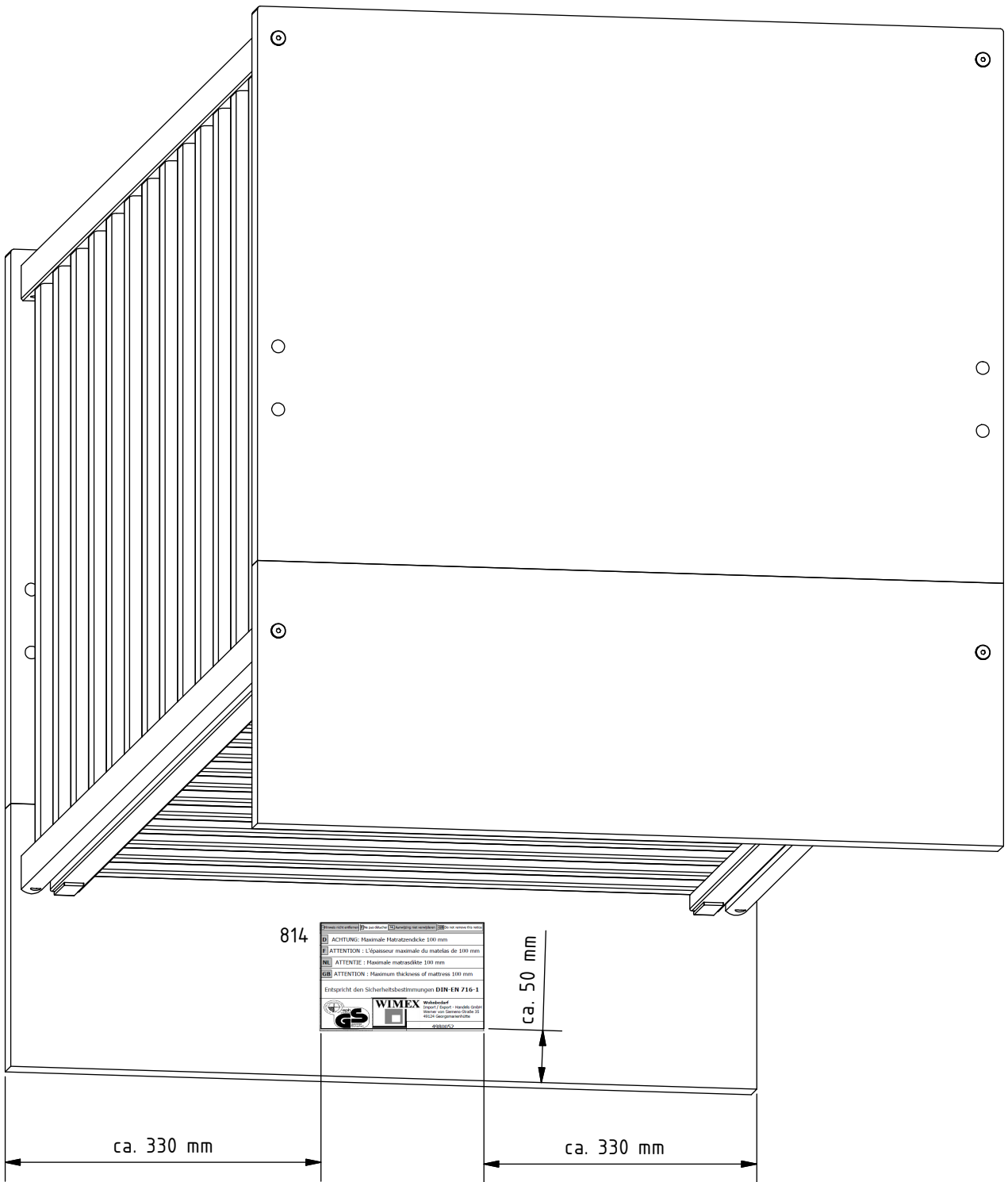

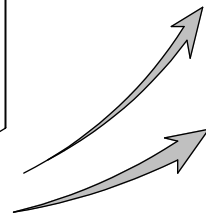
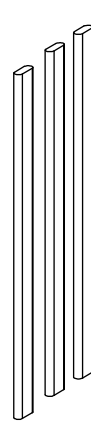
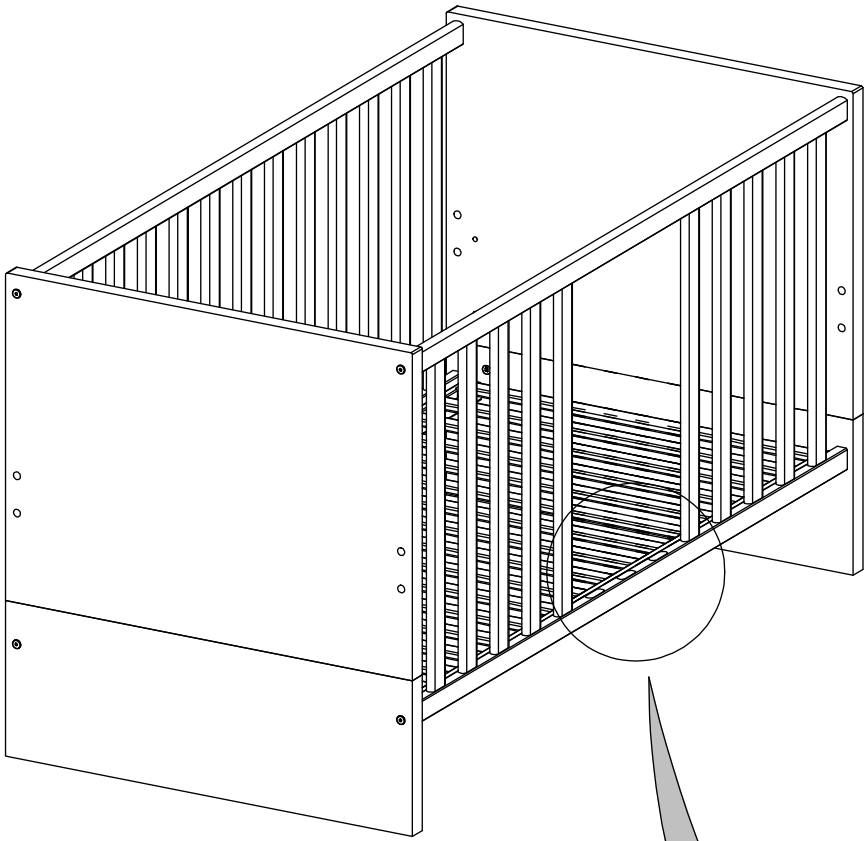

1+2+3

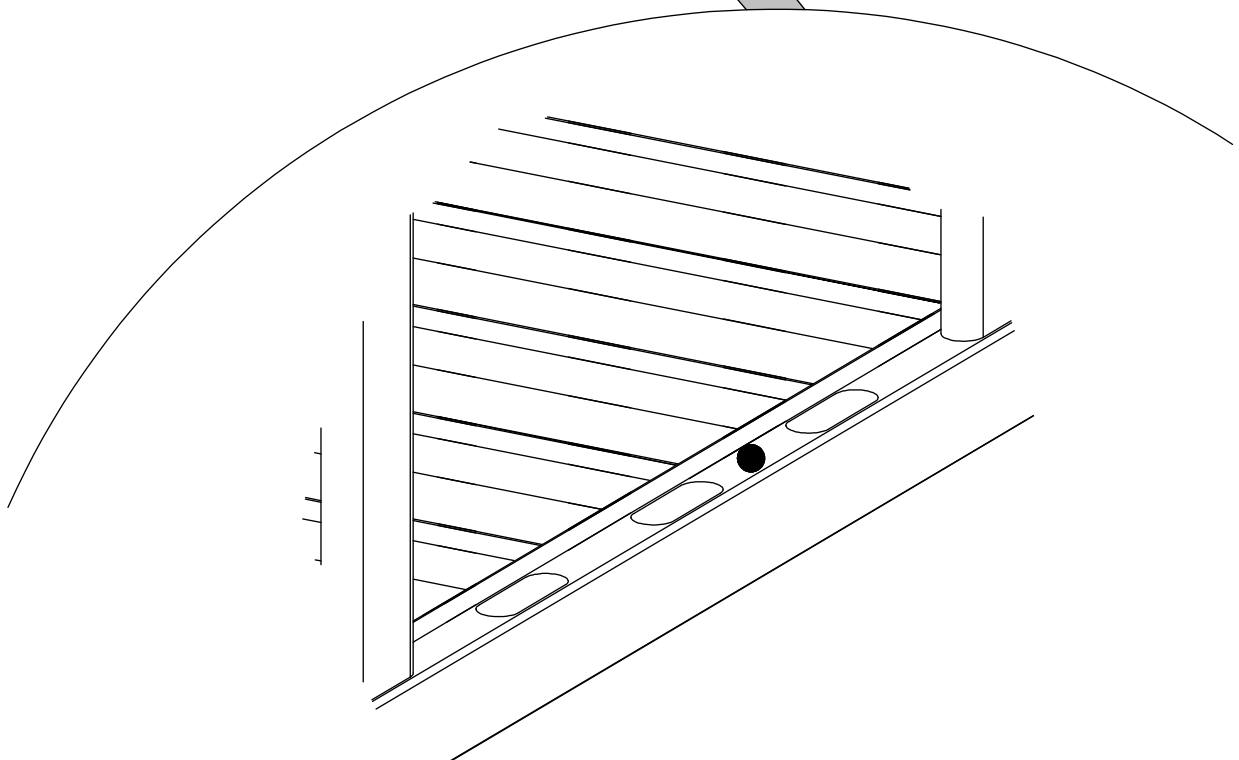

WICHTIG!:

BITTE SORGFÄLTIG LESEN UND FÜR SPÄTERE VERWENDUNG AUFBEWAHREN.

D

1. Alle Beschlagteile für die Montage müssen sachgemäß befestigt sein. Schrauben bitte fest anziehen, gegebenenfalls später einmal nachziehen um ein Hängenbleiben von Kleidungsstücken zu vermeiden. Es besteht ansonsten die Gefahr einer Strangulierung!
2. **WARNUNG: Das Kinderbett nicht in der Nähe von offenem Feuer oder anderen starken Hitzequellen wie elektrische Heizstrahler, Gasöfen usw. abstellen!**
3. Die Möbeloberfläche nur feucht abwischen. Bitte keine ätzenden Reinigungsmittel verwenden!
4. Der Bettboden ist in der Höhe 3-fach verstellbar. Die unterste Stellung ist die sicherste. Nur diese sollte verwendet werden, sobald das Kind so alt ist, um sich auf zu setzen.
5. Die Dicke der Matratze sollte 100mm betragen und muss so gewählt werden, dass die zu übersteigende Höhe (Matratzenoberfläche bis Oberkante des Bettrahmens) in höchster Stellung mindestens 200 mm und in niedrigster Stellung mindestens 500 mm beträgt!
6. Der rote Punkt am Gitter muss immer unten sein!
7. Zur Nutzung der Schlupfsprossen unbedingt alle Sprossen entfernen, um ein Steckenbleiben des Kindes zu verhindern.
8. Excenterverbindungen sind so zu montieren, dass die Abdeckkappen bündig abschließen und somit von Kindern nicht abgenommen werden können.
9. **WARNUNG: Das Kinderbett bitte nicht mehr benutzen, sollte ein Teil zerstört sein oder fehlen. Bitte verwenden Sie für die Reparatur nur vom Hersteller empfohlene Ersatzteile! Das Bett nicht mehr nutzen wenn das Kind groß genug ist um die Seiten zu übersteigen.**
10. **WARNUNG: Lassen Sie nichts im Bett liegen, dass das Kind als Fußhalt benutzen kann, oder das eine Gefahr des Strangulierens mit sich bringen kann, z.B. Schnüre, Gardinen- oder Vorhangkordel.**
11. Mindest Matratzengröße 1370 x 670 x 100 mm (empfohlene Matratzengröße 1400 x 700 x 100mm)
12. **WARNUNG: Benutzen Sie niemals mehr als eine Matratze im Kinderbett!**

IMPORTANT! PLEASE READ CAREFULLY AND KEEP FOR FUTURE REFERENCE.

GB

1. When assembling, please ensure that all fittings are correctly fastened. Please tighten screws securely and if necessary retighten at a later stage in order to prevent items of clothing catching in these. Otherwise there is the risk of strangulation.
2. **WARNING: Do not position the cot bed close to an open fire or other strong sources of heat such as electrical radiant heaters, gas ovens etc.**
3. Simply wipe the surface of the furniture with a damp cloth. Please do not use corrosive cleaning agents.
4. The base of the cot bed is adjustable in 3 levels. The lowest level is the safest and as soon as the child is old enough to sit upright, only this level should be used.
5. The thickness of the mattress should be 100 mm and must be selected to ensure that the height to be mounted (mattress surface to the top of the cot bed frame) is at least 200 mm in the highest position and at least 500 mm in the lowest position.
6. The red marking on the grid must always be facing downwards.
7. If you are taking out the removable bars, it is imperative that all the removable bars are taken out in order to prevent the child getting caught.
8. Eccentric adjustment bolts are to be assembled in such a way that the protective caps are flush and cannot be removed by children.
9. **WARNING: Please do not continue to use the cot bed if a part is damaged or missing. In the case of repairs, please use only spare parts that are recommended by the manufacturer. Do not use the cot bed once the child is big enough to climb over the sides.**
10. **WARNING: Leave nothing in the cot bed that your child could use to get their footing, or that could lead to strangulation, for example strings, or cords from curtains and drapes**
11. The minimum mattress size should be 1370 x 670 x 100 mm (Recommended mattress size 1400 x 700 x 100 cm)
12. **WARNING: Never use more than one mattress in the cot**

AVERTISSEMENT A LIRE ATTENTIVEMENT AVANT USAGE

F

1. Toute la quincaillerie d'assemblage doit toujours être fixée en totalité et de manière adéquate. Bien serrer les vis et les resserrer occasionnellement afin d'éviter de rester accroché par les vêtements. Danger d'étranglement.
2. **AVERTISSEMENT: Ne pas placer le lit auprès d'un feu ouvert ou autres sources de chaleur comme des radiateurs à rayonnement ou appareils de chauffage ou poêles à gaz etc.**
3. La surface du meuble doit être seulement essuyée humide. Ne pas utiliser des nettoyants décapants !
4. La base de lit est ajustable à 3 hauteurs. La position la plus basse est la plus solide. Dès que l'enfant est assez âgé pour se mettre dans une position debout, la position la plus basse est la seule à utiliser.
5. Choisir l'épaisseur du matelas de sorte que la hauteur qui dépasse du bord supérieur du cadre de lit soit de 500 mm au minimum à la position la plus basse de la base de lit et qu'elle soit de 200 mm au minimum à la position la plus haute de la base de lit.
6. Le point rouge aux barreaux doit être en bas.
7. Pour utilisation des barreaux amovibles on doit absolument enlever tous les barreaux amovibles afin d'éviter que l'enfant peut être bloqué.
8. Les excentriques de vis de jonctions doivent être montés serrés de manière à ce que les « bonnets » de protection ferment hermétiquement et ne peuvent pas être démontés par des enfants.
9. **AVERTISSEMENT: Ne pas utiliser le lit d'enfant si une pièce manque ou est cassée. Veuillez seulement utiliser des pièces de réchange recommandées par le producteur. Ne plus utiliser le lit lorsque l'enfant est assez grand pour passer dessus les côtés.**
10. **AVERTISSEMENT: Ne laisser rien dans le lit que l'enfant pourrait utiliser comme banc ou qui implique un risque d'étranglement tel que des ficelles ou une corde de rideau.**
11. Taille minimale du matelas 1370 x 670 x 100 mm (taille de matelas recommandée 1400 x 700 x 100 mm)
12. **AVERTISSEMENT: Ne jamais utiliser plus d'un matelas dans le lit**

AANDACHTIG te lezen vóór gebruik

NL

1. alle beslag (schroeven ed.) dient volledig en correct gefixeerd te zijn op de juiste wijze alle schroeven dienen volledig ingeschroefd te zijn. Onvolledig ingeschroefde vijzen kunnen tot kwetsuren en vasthaken van kleding leiden waardoor mogelijk risico / gevaar tot wurging kan ontstaan.
2. **WAARSCHUWING: Het bed nooit in de nabijheid van verwarmingselementen (vuur en andere warmtebronnen zoals gaskachels) opstellen.**
3. De meubels reinigen met een vochtige doek. Aub géén chemische reinigingsmiddelen gebruiken.
4. De bedbodem kan op 3 hoogten gemonteerd worden. De laagste stand is de meest stabiele- Zodra het kind zich staande kan houden is het aanbevolen enkel de laagste stand te gebruiken.
5. De dikte van de matras moet dermate gekozen worden om de volgende hoogtemaat te bekomen: van matras tot boord van het bedraam in de laagste stand 500 mm en in de hoogste stand 200 mm minimum.
6. Het rode punt op de spijlen dient zich steeds ondraan te bevinden.
7. Bij het gebruik van verstelbare spijlen dienen alle verstelbare spijlen weggenomen te worden om te vermijden dat het kind zou komen vast te zitten.
8. De excenters voor de verbindingvijzen moeten volledig sluitend gemonteerd worden, derwijz dat de afdekkappen hermetisch afsluiten en niet door kinderen gedemonteerd kunnen worden.
9. **WAARSCHUWING: Her kinderbed niet meer gebruiken, indien er een onderdeel kapot is of ontbreekt. Bij eventuele reparatie alléén die reserve onderdelen gebruiken, die door de fabrikant zijn aanbevolen. Het bed niet meer gebruiken als het kind groter is dan de hoogte van de bedzijden.**
10. **WAARSCHUWING: Laat het kind niet in het bed liggen., als het bed gebruikt kan worden als "opstap", hierdoor zou er een gevaar kunnen ontstaan tot wurging, door bijvoorbeeld snoeren of gordijnen.**
11. Minimale matrasafmeting 1370 x 670 x 100 mm (aanbevolen matrasmaat 1400 x 700 x 100 mm)
12. **WAARSCHUWING: Gebruik nooit meer dan een matras in de wieg**

IMPORTANTE!: Si prega di leggere attentamente e conservare per uso futuro

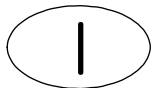



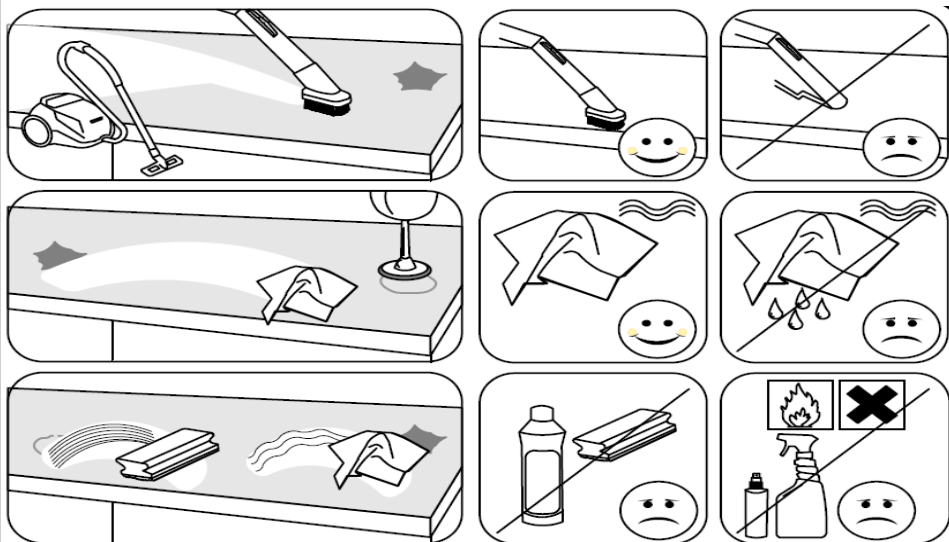

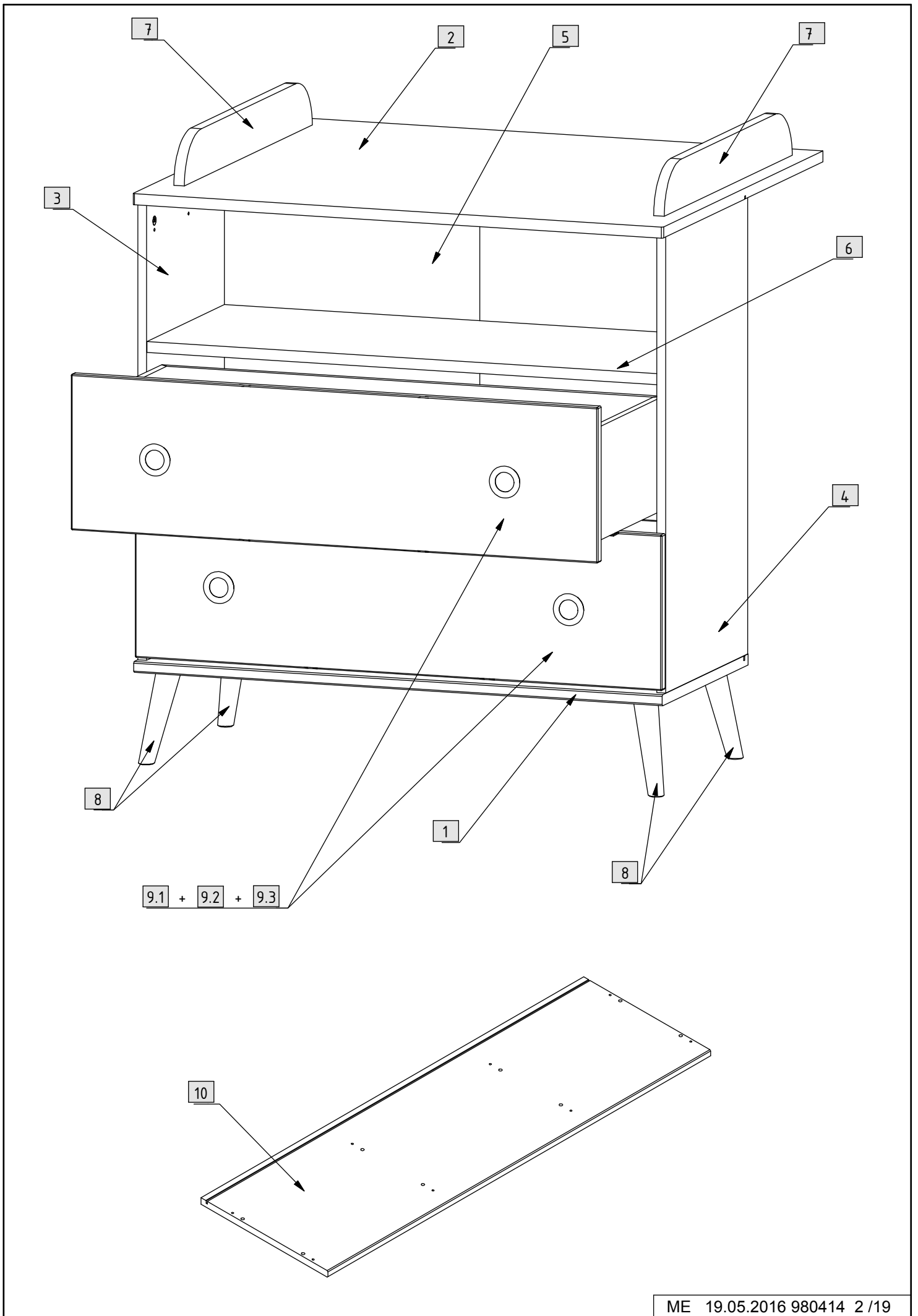

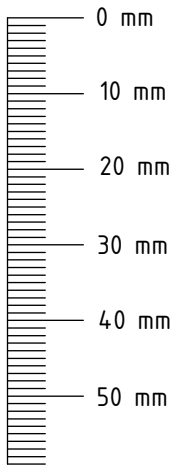
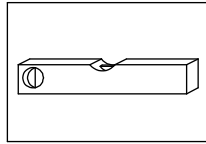
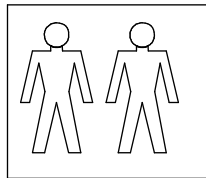

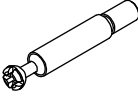
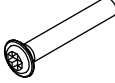

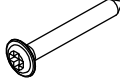
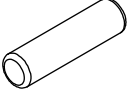
1. Tutti raccordi devono essere fissati correttamente. Le vite devono essere avvitate saldamente. Per evitare che il abbigliamento resta intrappolato, si prega a stringere le vite se ce di bisogno.
2. **AVVERTIMENTO: I letti dei bambini non devono essere parcheggiati vicino al fuoco o altro fonte di calore come riscaldatore elettrico, forno a gas ...)**
3. La superficie dei mobili puo essere pulito solo con un panno umido. Non usare detergente.
4. La superficie reclinabile puo essere regolato in altura in 3 fasi. La piu bassa e la piu sicura. Quando il bambino/la bambina raggiunge un'età che si puo sedere, solo il livello piu basso si dovrebbe usare.
5. Il spessore del materasso deve essere 100mm e deve essere selezionato cosi, che dal superficie del materasso fine al telaio del letto hai al minimo 200mm in livello piu alto, e minimo 500mm in livello piu basso.
6. Il punto rosso nella griglia deve essere sempre sotto!
7. Per fare un spazio nelle pannelli laterale, togliere tutte 3 pannelli, per evitare che il bambino si incastra.
8. La copertura del eccentrico deve essere installato a filo per evitare che il bambino lo puo togliere.
9. **AVVERTIMENTO: Se arriva un pezzo rotto o manca qualcosa non usare il letto. Solo usare i pezzi ricambi raccomandati del fabbricante! Non usare il letto se il bambino e cosi grande che puo superare i pannelli laterali.**
10. **AVVERTIMENTO: Non lasciare niente nel letto che crea il pericolo che il bambino si strangola (Cavo, Tenda, ...)**
11. La misura minima per il materasso e 1370x670x100mm (misura raccomandata e 1400x700x100mm)
12. **AVVERTIMENTO: Non usare mai di piu di un materasso in questo letto.**

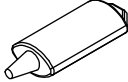
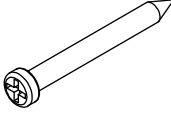
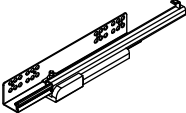

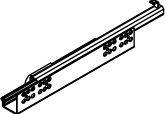
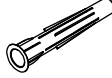

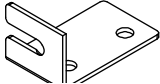

116	12		348	4	 4 x 25 mm
120	12		354	2	 3,5 x 25 mm
190	12	 Ø8 x 30mm	370	14	 4 x 15 mm
204	2		371	5	 6 x 60 mm
214 L	2		509	4	
214 R	2		741	1	
220	18		742	1	
304	8	 6 x 11 mm	817	1	

2x

9.2

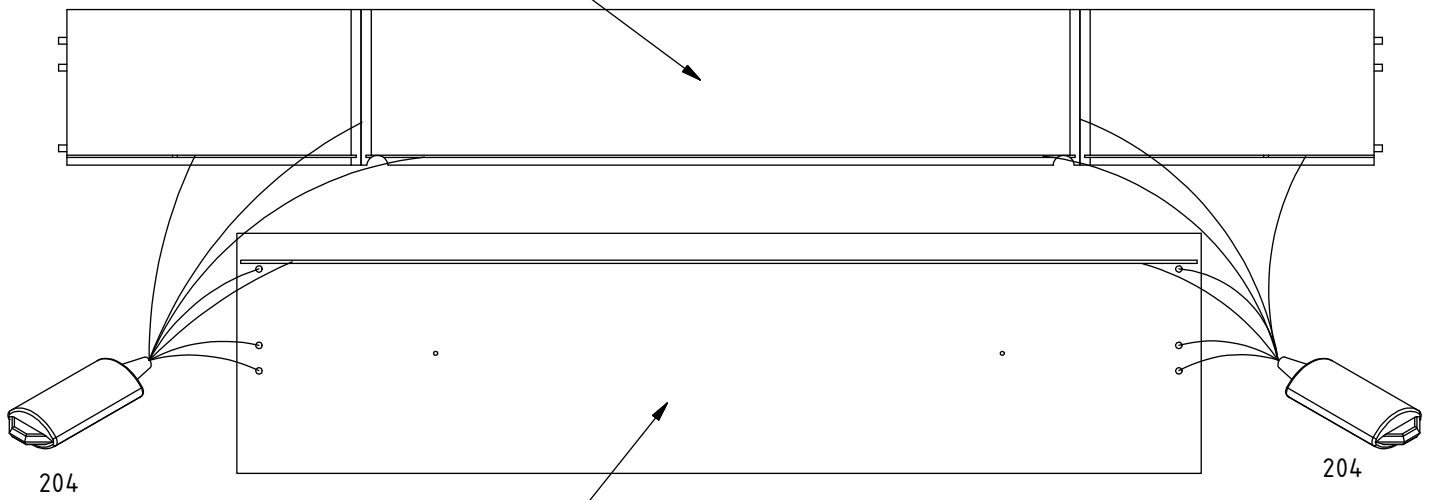

204

204

9.1

9.2

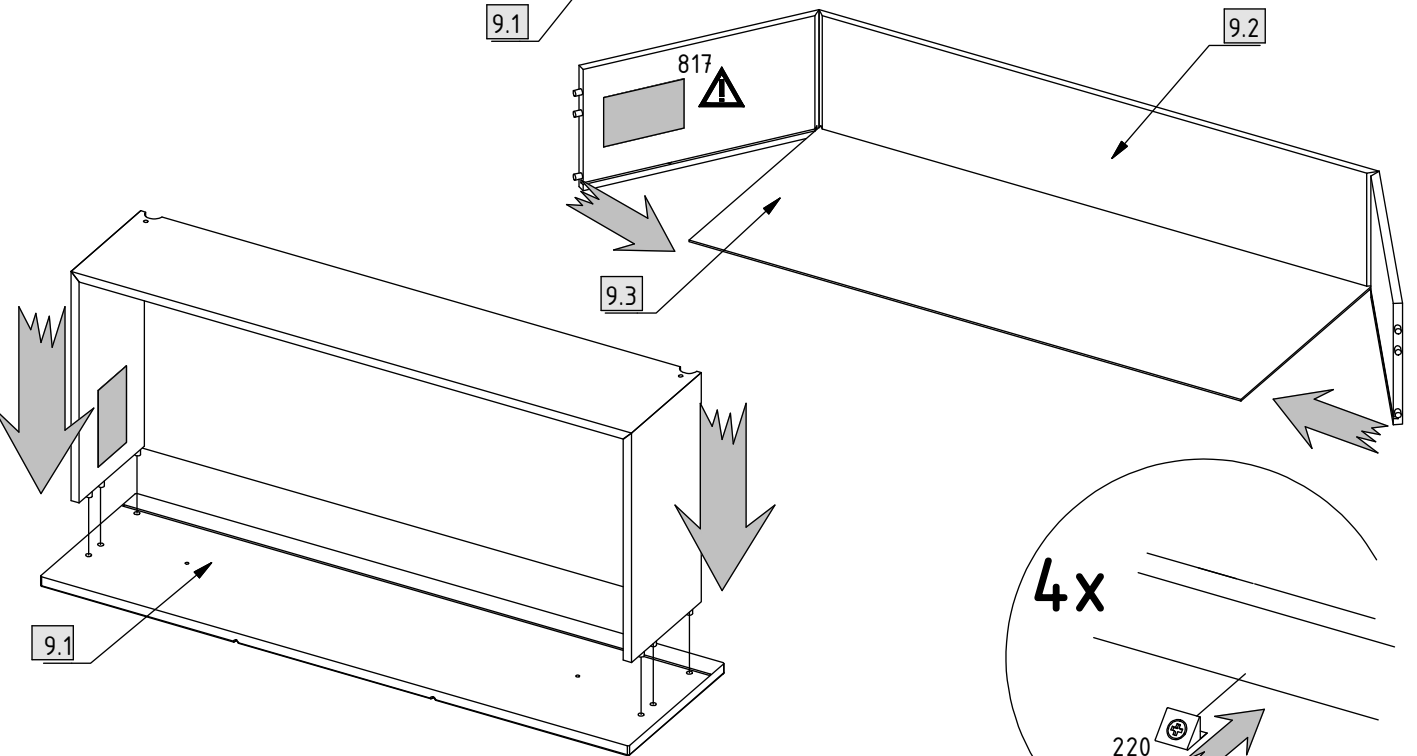

817

9.3

4x

220

220

220

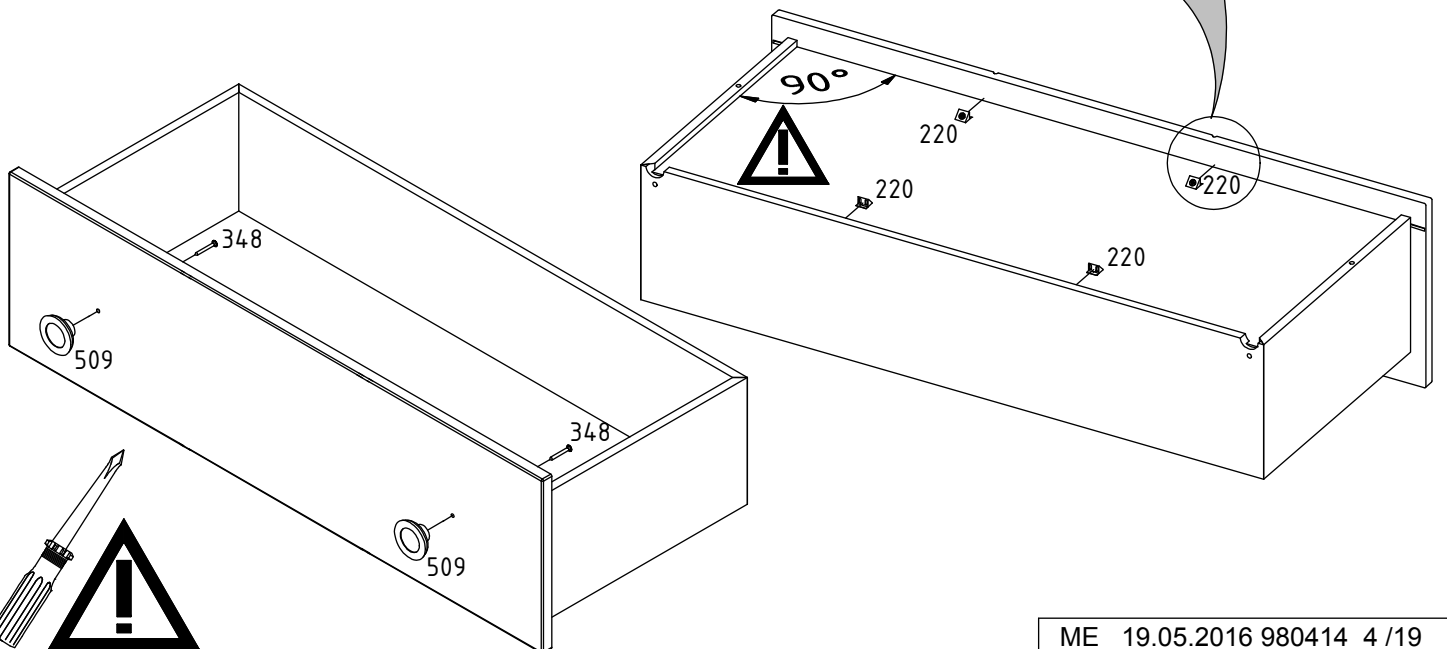

90°

220

220

220

220

509

348

348

509

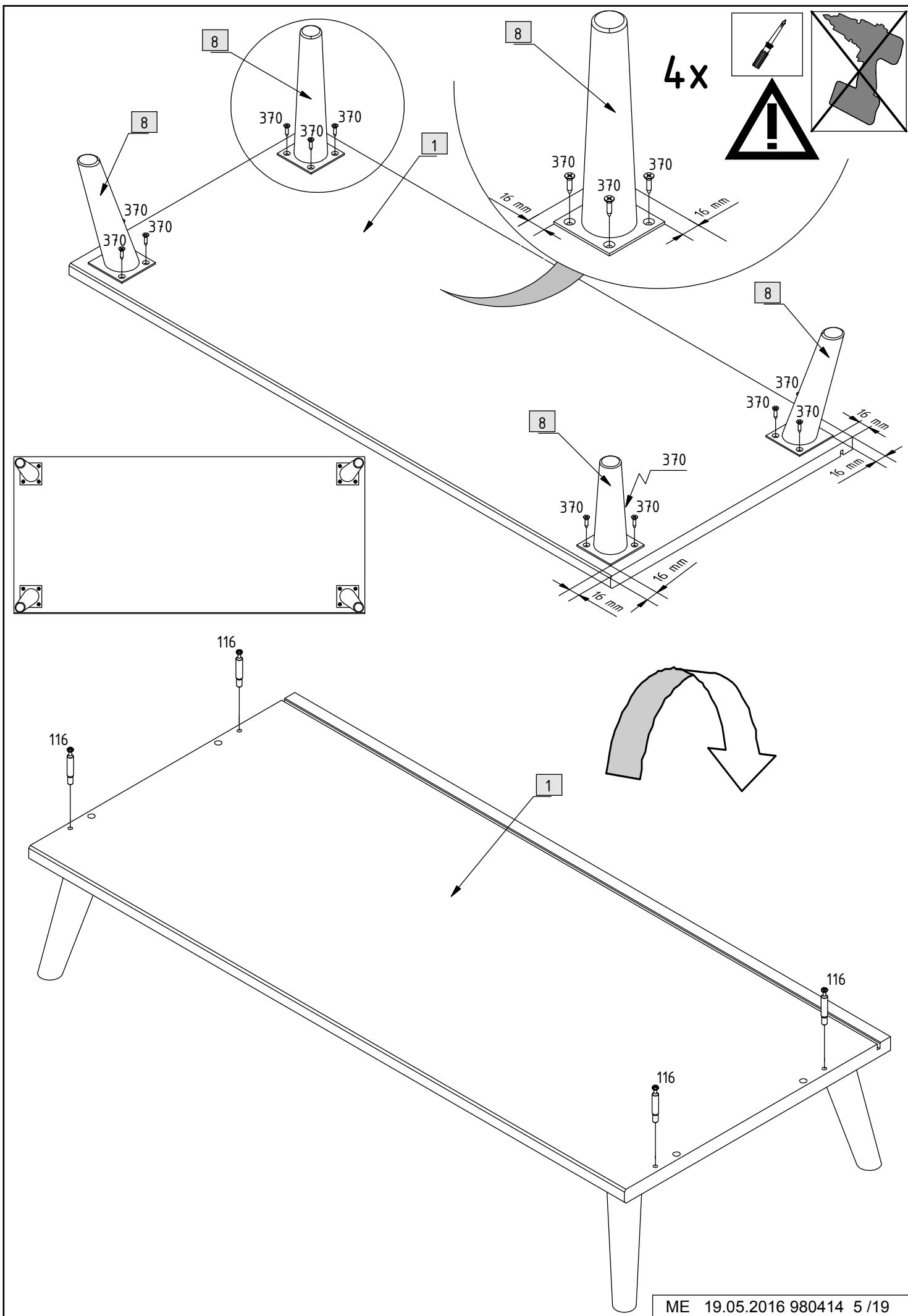

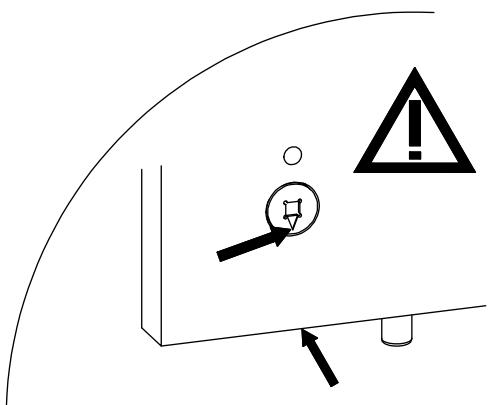
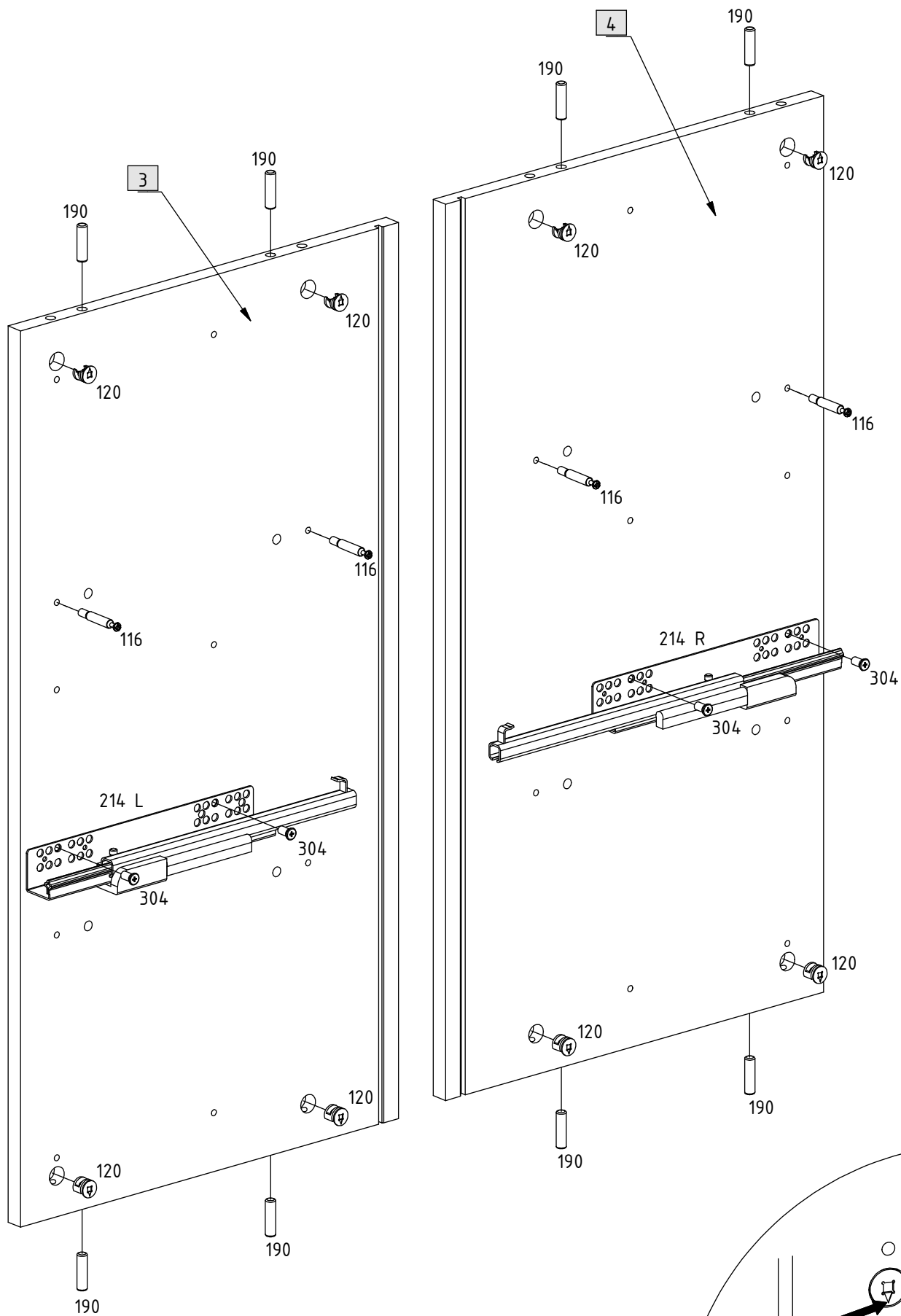

4x

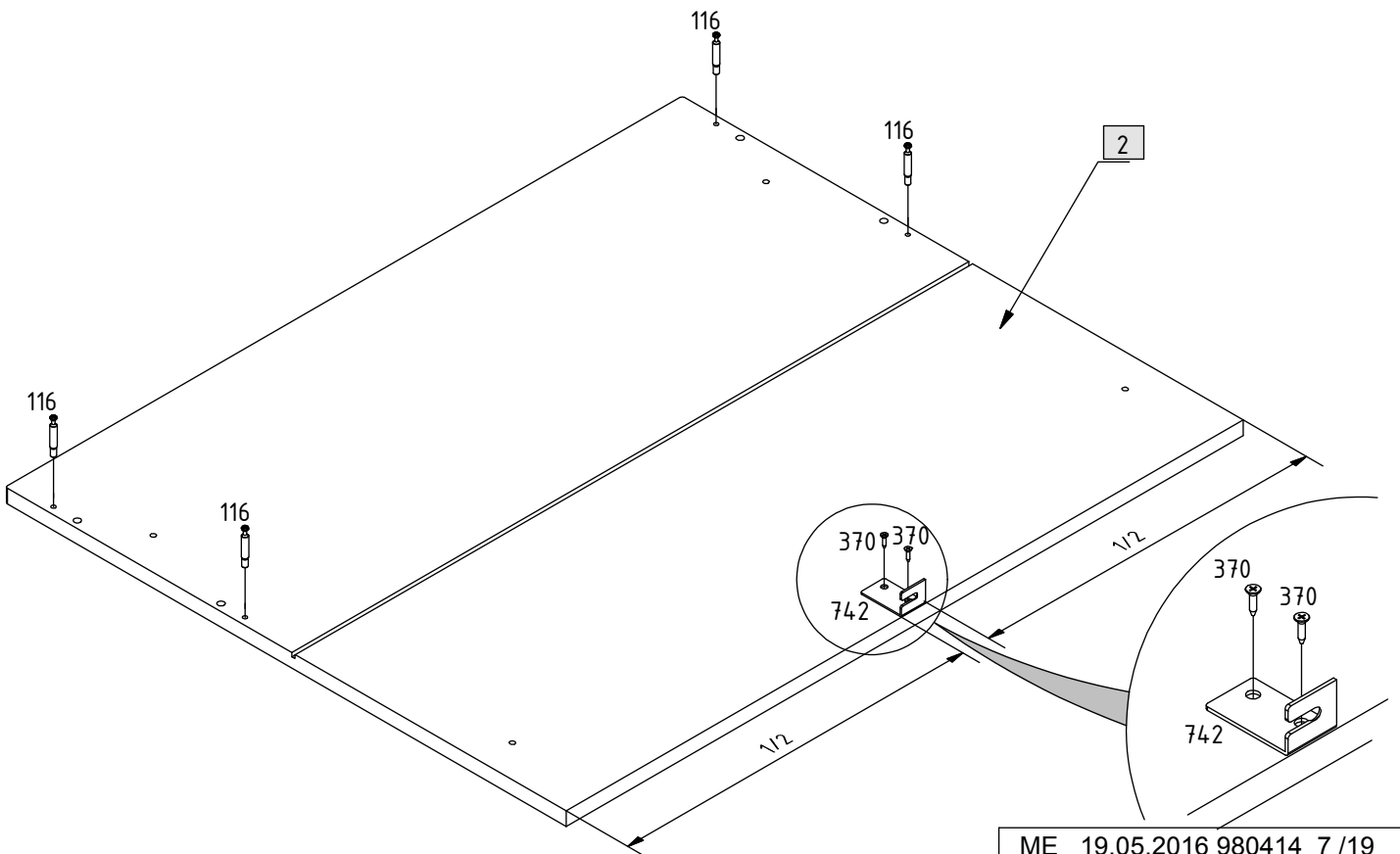
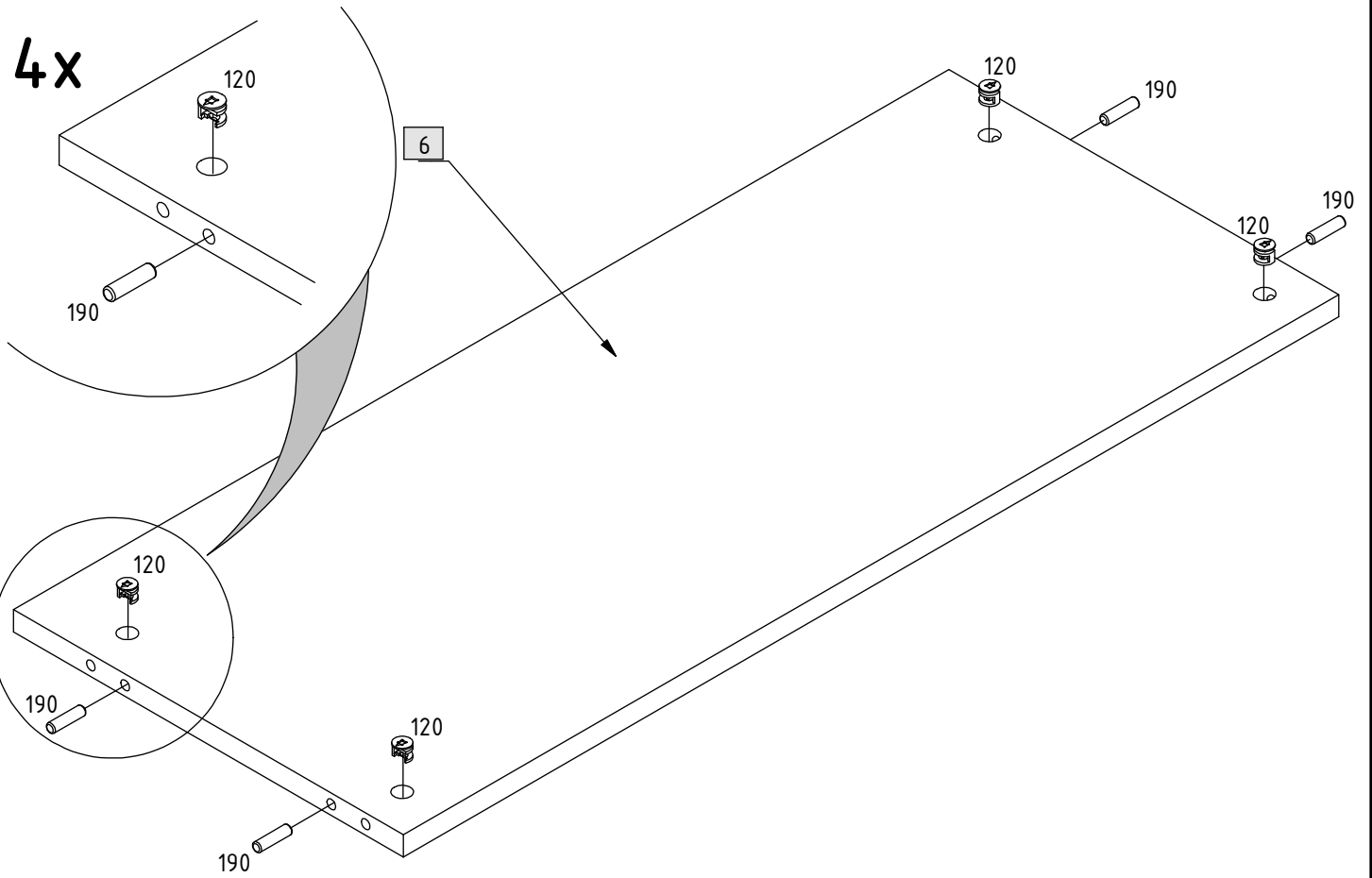

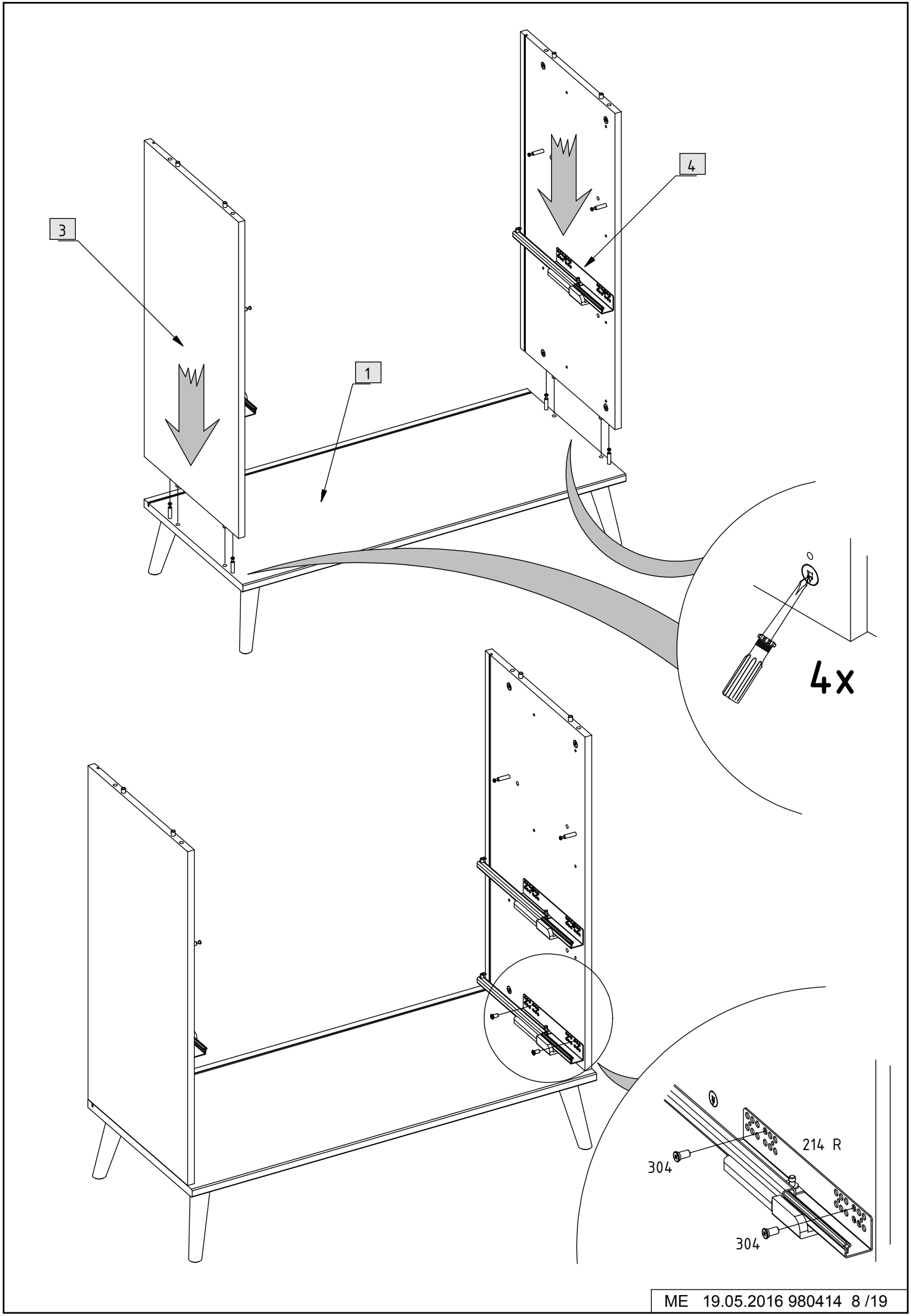

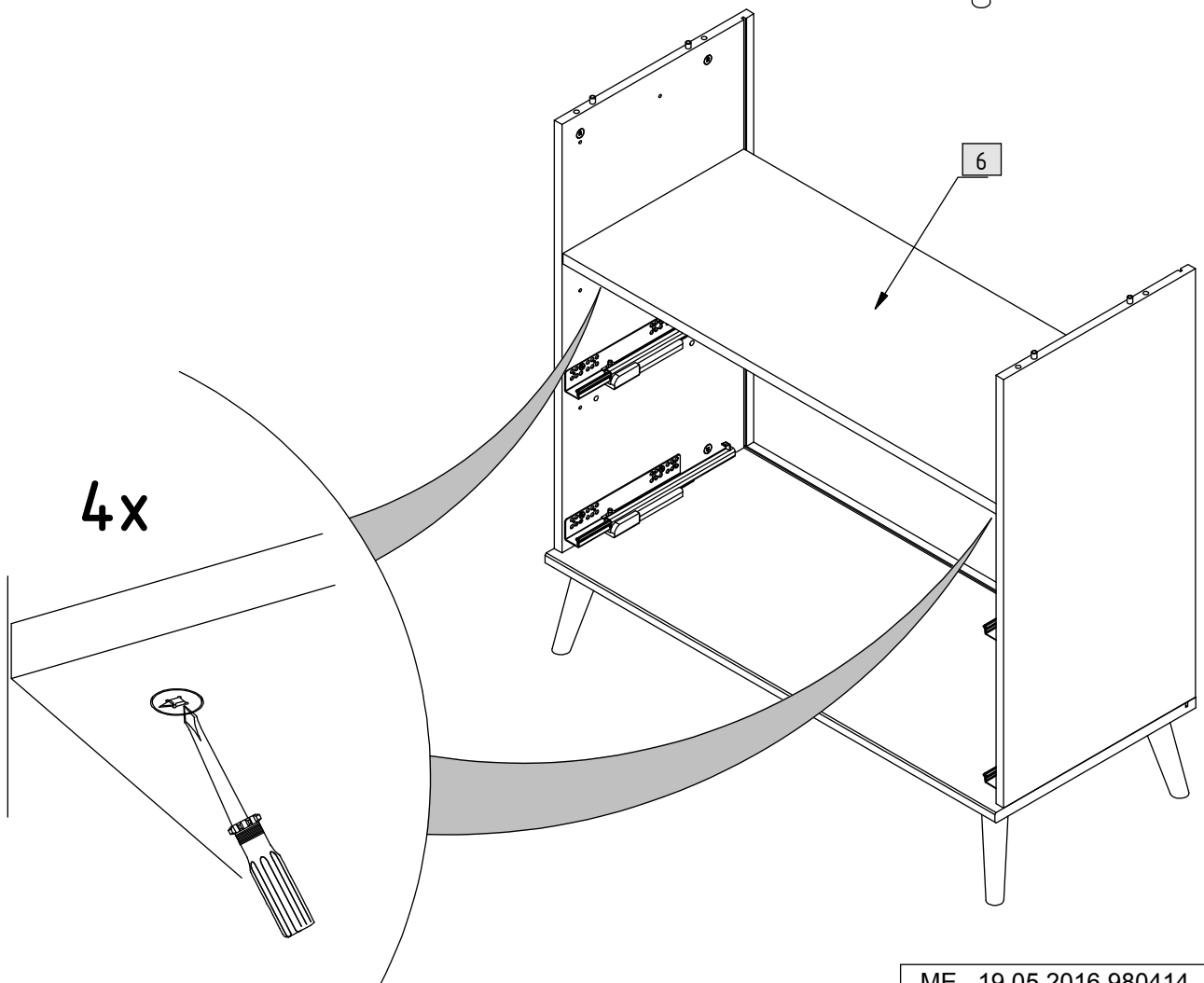
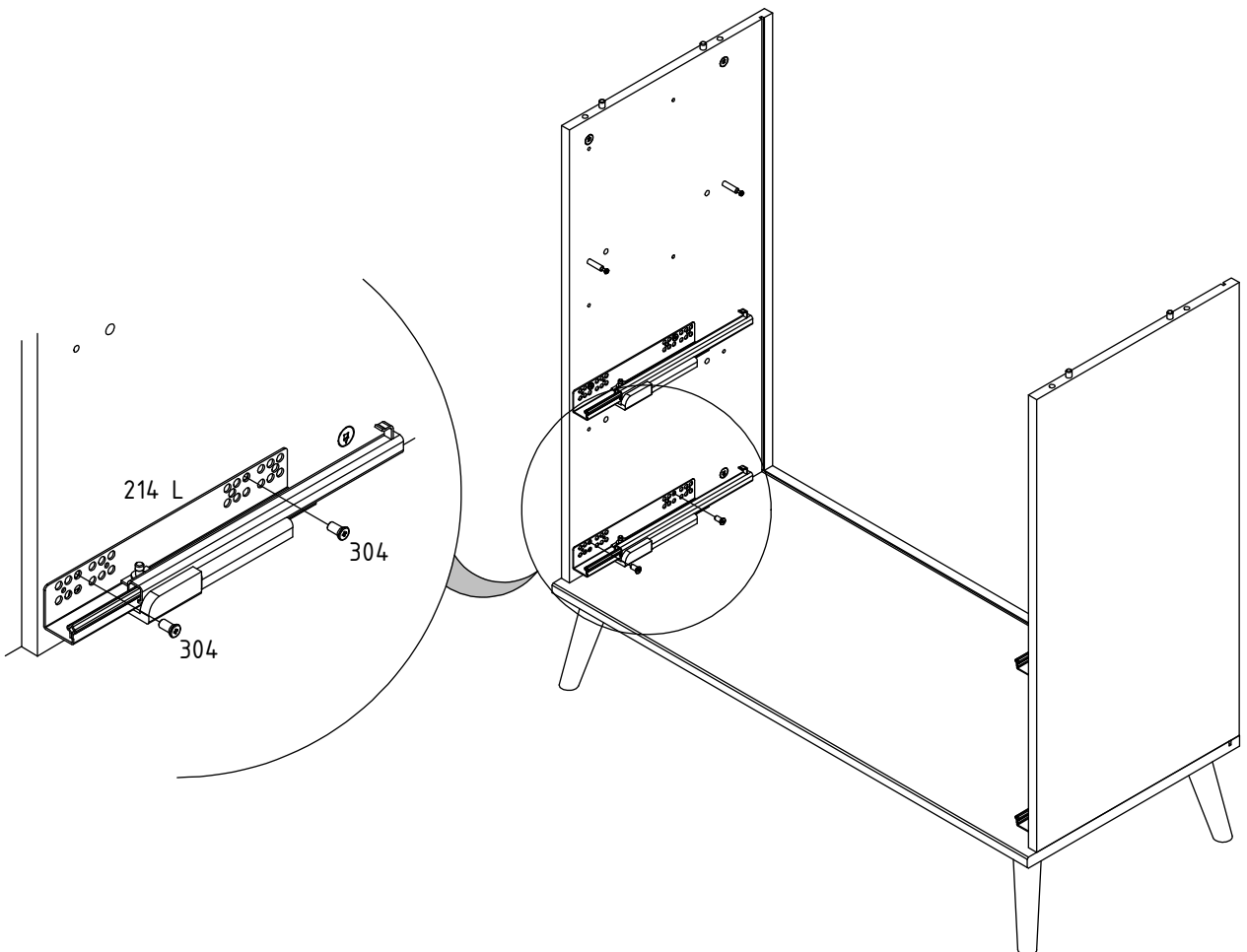

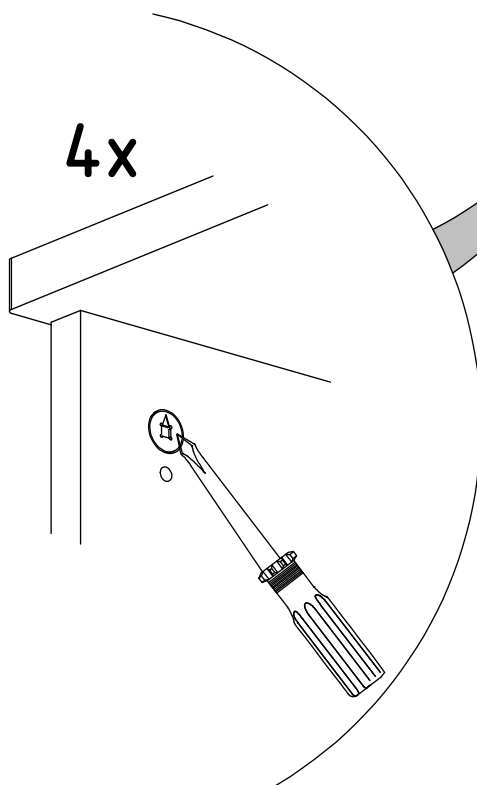
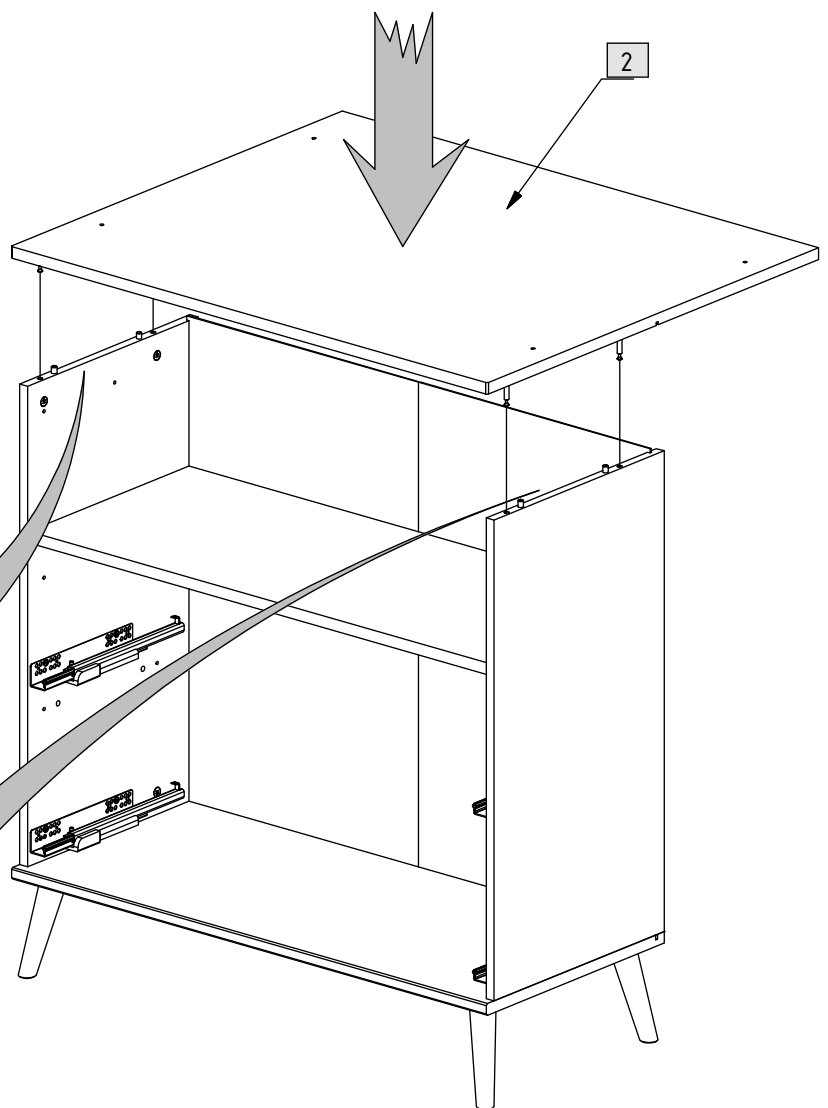
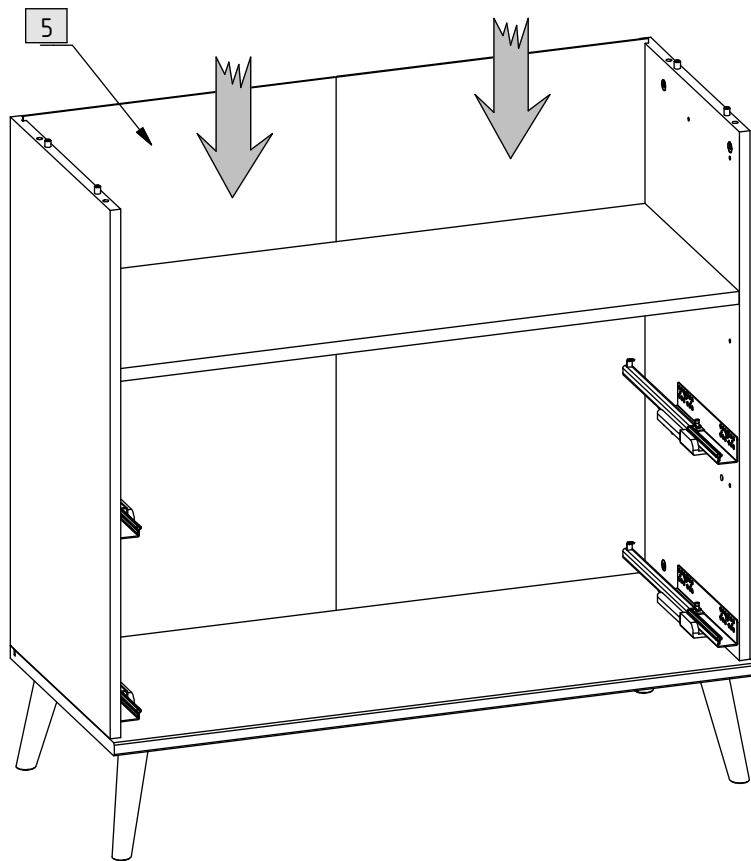

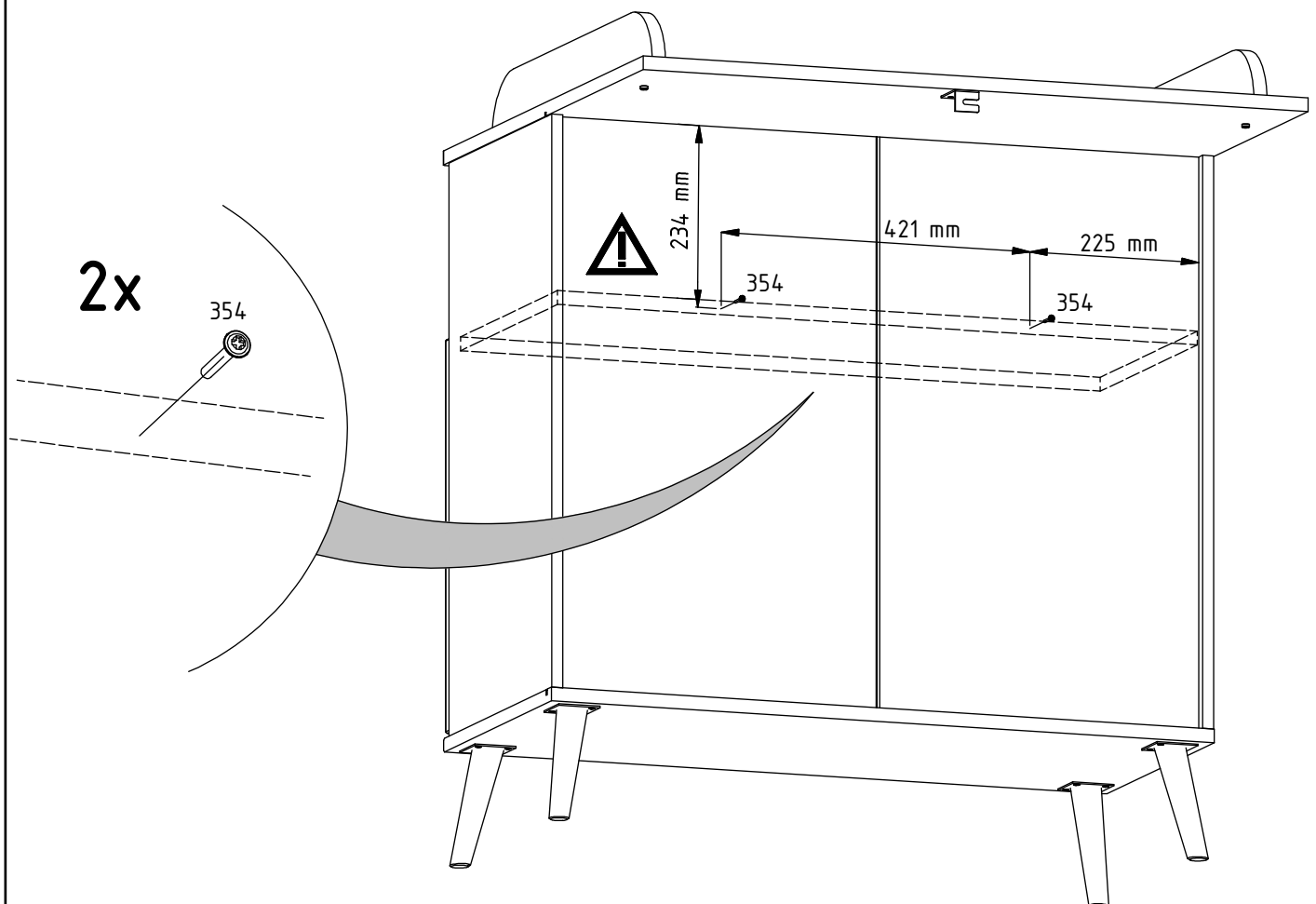
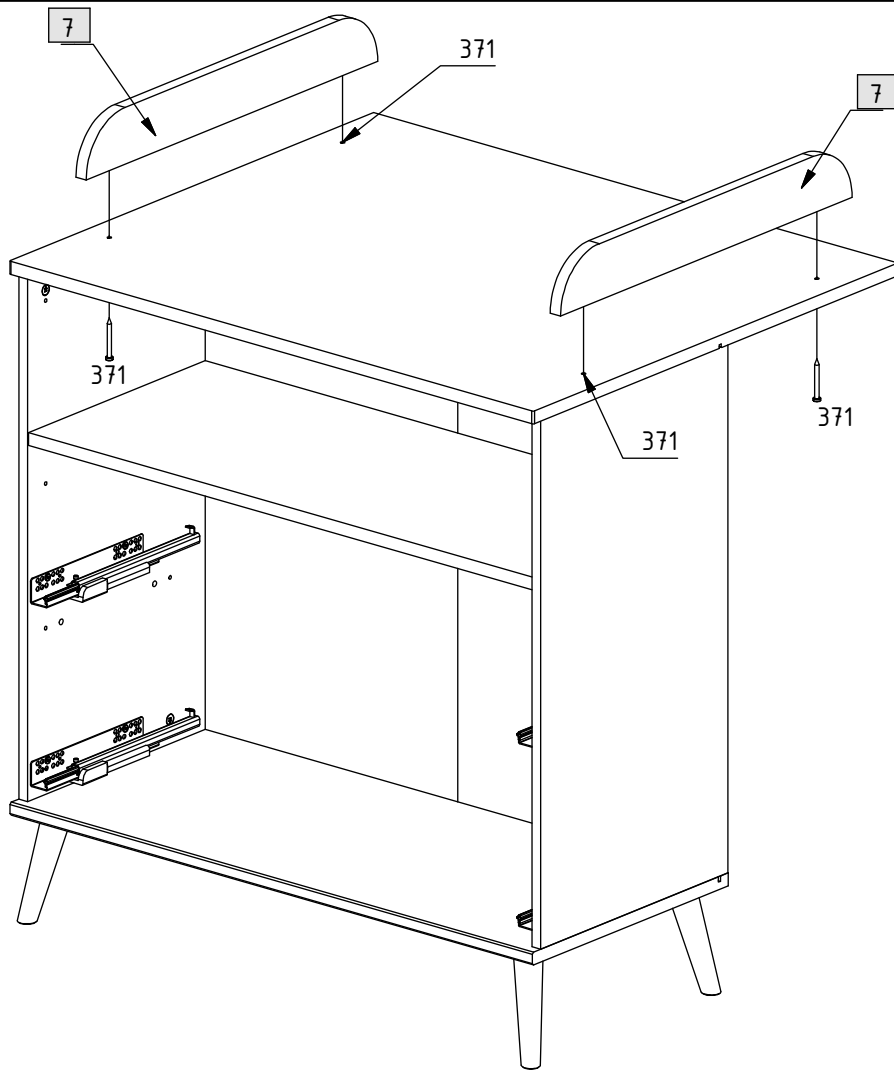

2x

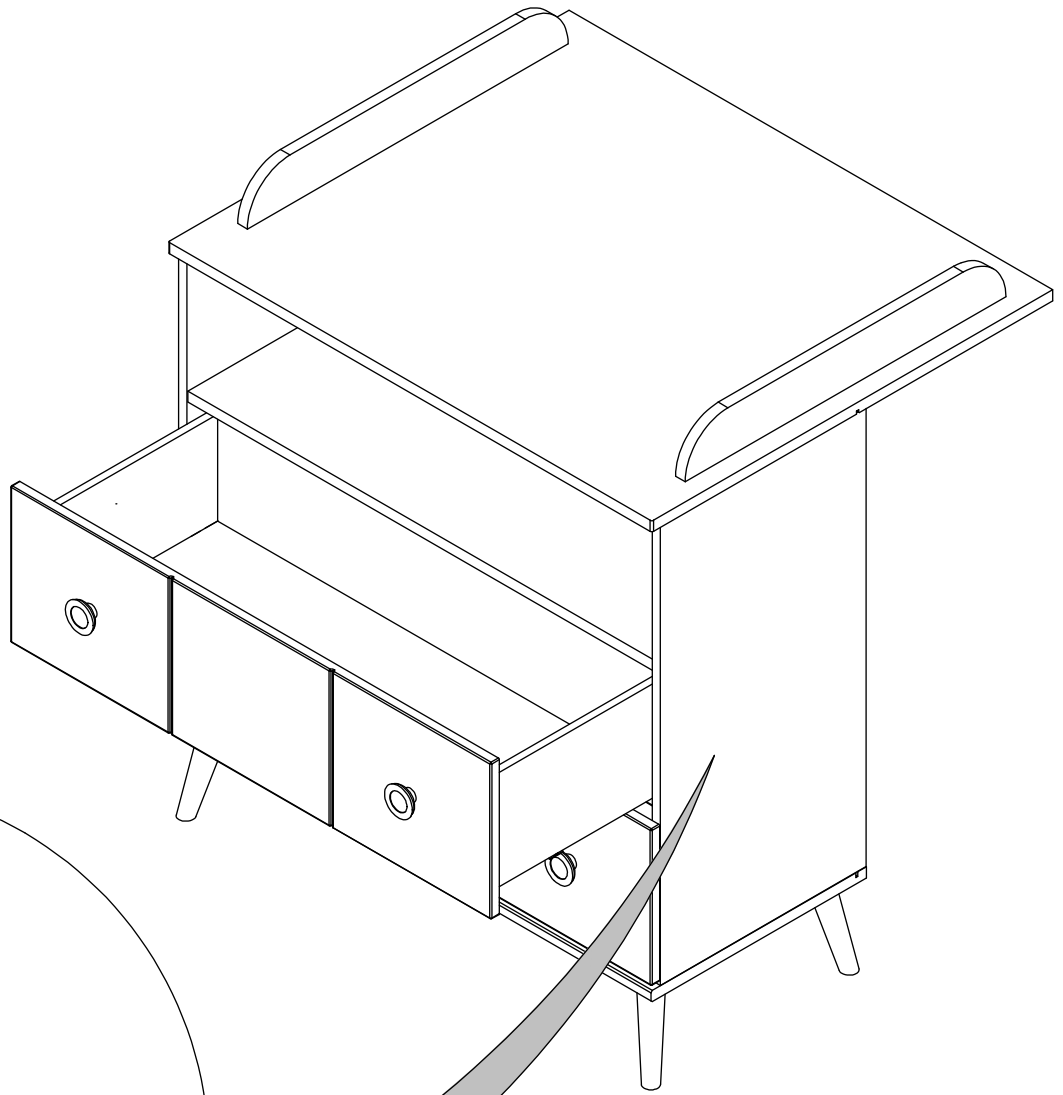

1.

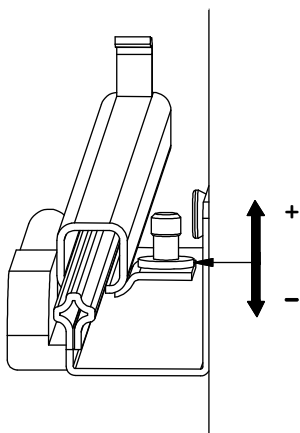
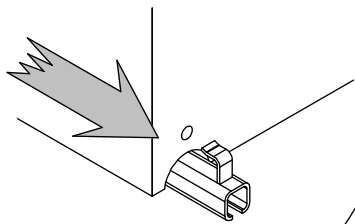

2.

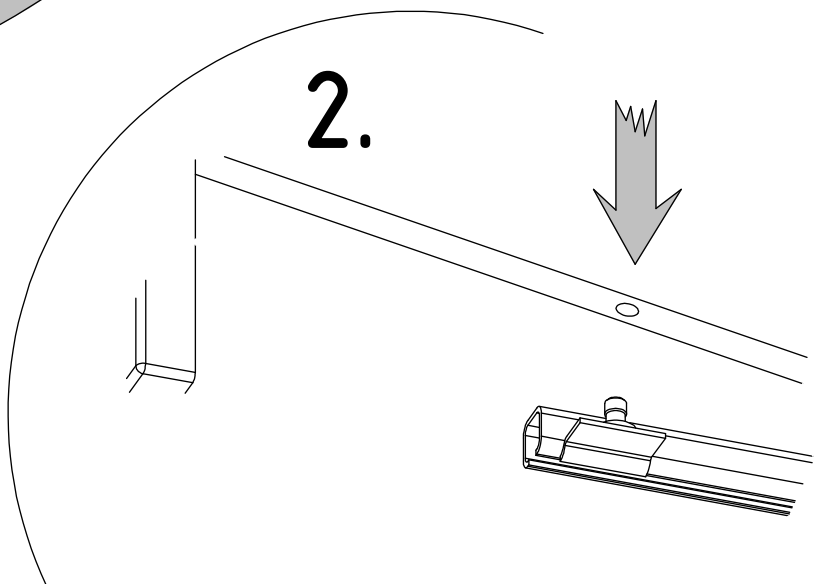

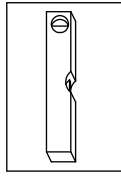
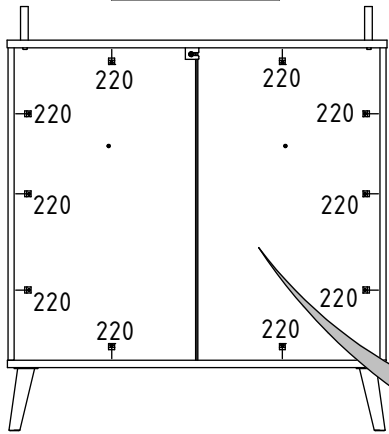
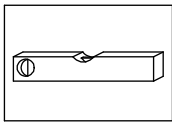

10x

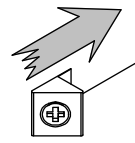

220

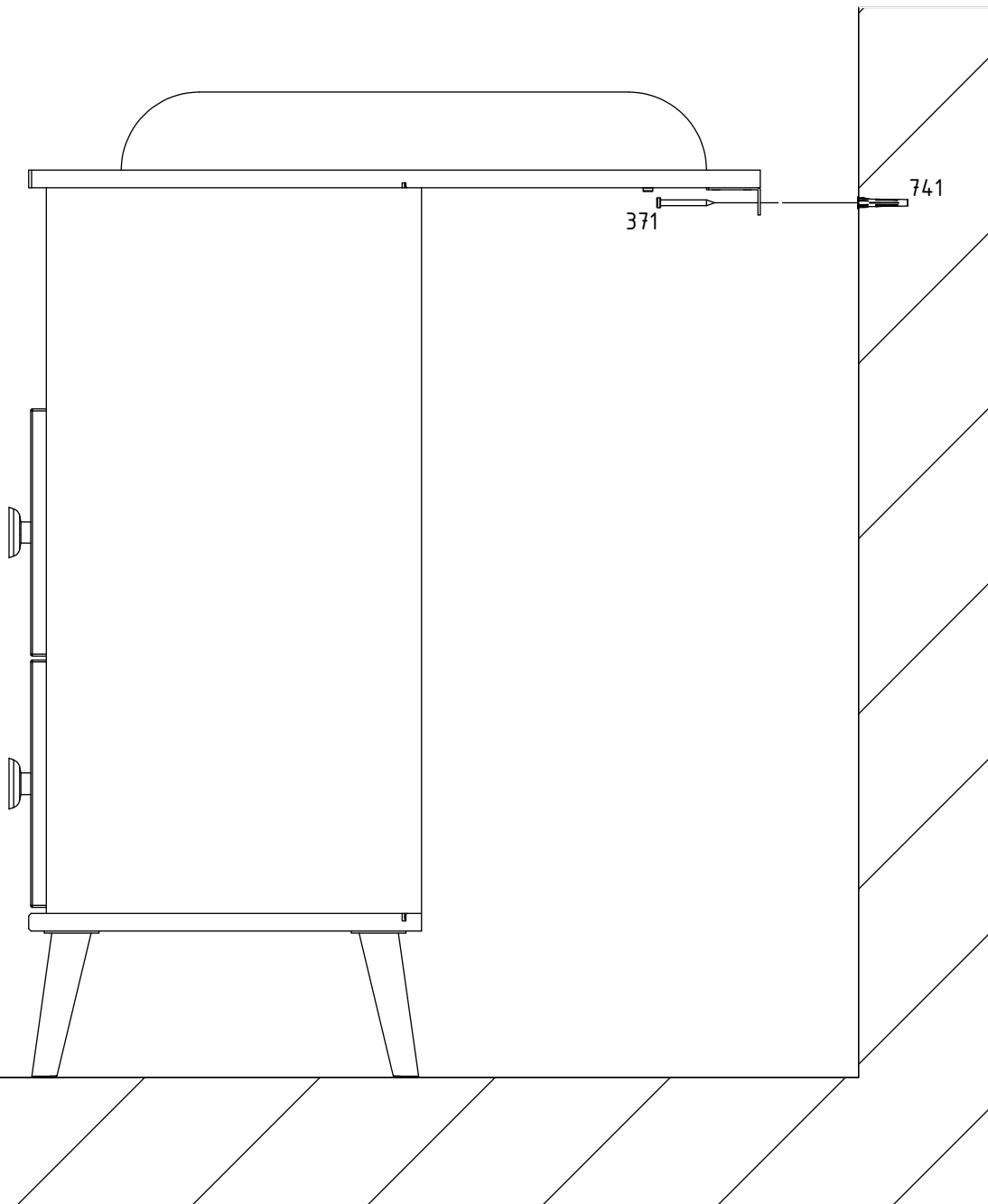

WICHTIG!:

BITTE SORGFÄLTIG LESEN UND FÜR SPÄTERE VERWENDUNG AUFBEWAHREN.

D

1. Nutzung des Möbels als Wickelkommode nur mit entsprechender Wandbefestigung!
2. Prüfen Sie, ob sich die gelieferten Beschläge zur Wandbefestigung für die Montage an Ihrer Wand eignen!
3. Alle Beschlagteile für die Montage müssen sachgemäß befestigt sein. Schrauben bitte fest anziehen, gegebenenfalls später einmal nachziehen um ein Hängenbleiben von Kleidungsstücken zu vermeiden. Es besteht ansonsten die Gefahr einer Strangulierung!
4. Die Wickelkommode nicht in der Nähe von offenem Feuer oder anderen starken Hitzequellen wie elektrische Heizstrahler, Gasöfen usw. abstellen!
5. Die Möbeloberfläche nur feucht abwischen. Bitte keine ätzenden Reinigungsmittel verwenden!
6. **Warnung:** Bitte Kinder nie unbeaufsichtigt auf der Wickelauflage liegen lassen. Das Gewicht des Kindes für das das Produkt ausgelegt ist, beträgt max. 15 kg!
7. Die Wickelkommode bitte nicht mehr benutzen, sollte ein Teil zerstört sein oder fehlen, Bitte verwenden Sie für die Reparatur nur vom Hersteller empfohlene Ersatzteile!
8. Verwenden Sie immer eine weiche, handelsübliche Wickelauflage mit einer maximalen Dicke von 40mm auf der Oberseite der Wickelkommode, damit eine ausreichend verbleibende Höhe der umseitigen Absturzsicherungen vorhanden ist!

IMPORTANT! PLEASE READ CAREFULLY AND KEEP FOR FUTURE REFERENCE.

GB

1. This piece of furniture should only be used as a baby changing unit with the appropriate wall fastenings.
2. Please verify that the fittings delivered for fastening the unit onto the wall are suitable for your wall.
3. When assembling, please ensure that all fittings are correctly fastened. Please tighten screws securely and if necessary retighten at a later stage in order to prevent items of clothing catching in these. Otherwise there is the risk of strangulation.
4. Do not position the changing unit close to an open fire or other strong sources of heat such as electrical radiant heaters, gas ovens etc.
5. Simply wipe the surface of the furniture with a damp cloth. Please do not use corrosive cleaning agents.
6. **Warning:** Please never leave children unattended on the changing unit. The product is designed for a maximum child weight of 15 kg.
7. Please do not continue to use the changing unit if a part is damaged or missing. In the case of repairs, please use only spare parts that are recommended by the manufacturer.
8. Please use always a soft and commercial cushion not thicker than 40mm in order to assure a sufficient remaining height for the security of the drop structure.

AVERTISSEMENT A LIRE ATTENTIVEMENT AVANT USAGE

F

1. Le meuble ne pourra être utilisé comme table à langer que lorsqu'il est fixé au mur de manière adéquate.
2. Vérifier si la quincaillerie fournie convient pour la fixation à votre mur!
3. Toute la quincaillerie d'assemblage doit toujours être fixée en totalité et de manière adéquate. Bien serrer les vis et les resserrer occasionnellement afin d'éviter de rester accroché par les vêtements.
Danger d'étranglement!
4. Ne pas placer le table à langer près d'un feu ouvert ou d'autres sources de chaleur comme des radiateurs à rayonnement ou des appareils de chauffage ou poêles à gaz etc!
5. Pour nettoyer la surface du meuble, l'essuyer avec un chiffon humide. Ne pas utiliser des produits de nettoyage décapants.
6. **Avertissement** : Ne jamais laisser les enfants sur la table à langer sans surveillance. La table à langer est conçue pour un poids maximum de l'enfant de 15 kg!
7. Ne plus utiliser la table à langer si une pièce manque ou est cassée. N'utiliser que les pièces de rechange recommandées par le fabricant.
8. Merci de toujours utiliser un coussin à langer d'épaisseur inférieure à 40 mm, pour préserver une hauteur suffisante de sécurité pour l'encadrement du plateau à langer.

AANDACHTIG te lezen vóór gebruik

NL

1. Gebruik van kommode alléén met de daarvoor bestemde wandbevestiging!
2. Controleert U aub, of U in het bezit bent van het wandbevestigings-beslag!
3. Alle beslag onderdelen voor de montage moeten vakkundig worden bevestigd. De schroeven aub vastdraaien om het blijven haken van kleding te voorkomen. Es bestaat anders een gevaar voor wurging.
4. De kommode niet in de buurt van open vuur of andere sterke hittebronnen, zoals hete-lucht kachels of gasovens plaatsen.
5. De meubels reinigen met een vochtige doek. Aub geen chemische reinigingsmiddelen gebruiken!
6. **waarschuwing**: Kinderen niet zonder toezicht op de kommode laten liggen. De kommode is er opgebouwd dat het kind maximal 15 kg mag wegen.
7. De kommode niet meer gebruiken, indien er een onderdeel kapot is of ontbreekt. Bij eventuele reparatie alléén de reserve onderdelen gebruiken, die door de fabrikant zijn aanbevolen!
8. Wij adviseren met nadruk om naast het gebruik van een officieel aankleedkussen met een maximale hoogte van 40 mm, de veiligheid van de baby ten alle tijden in acht te nemen. Dit in verband met de hoogte van dit meubel.

IMPORTANTE!:

LEGGERE ACCURATAMENTE E CONSERVARE PER FUTURA CONSULTAZIONE.



1. Uso del mobile come fasciatoio solo con connessione adatta alla parete !
2. Controlli se le ferramenta nell'imballaggio si adattano per il montaggio alla vostra parete !
3. Tutte le parti di montaggio devono sempre essere correttamente montate e controllate regolarmente. Assicurarsi che tutte le viti e gli altri elementi di fissaggio siano ben avvitati e stretti e che nessuna vite sia allentata (l'azienda si astiene da ogni responsabilità), in quanto potrebbe ferire il bambino o far impigliare i suoi vestitini (catenelle e simili, nastri, succhiotti, etc.) con il rischio di strangolamento.
4. Non posizionare mai l'articolo vicino a fonti di calore (pericolo di incendio). I sistemi di riscaldamento elettrici e a gas e tutte le altre fonti di calore rappresentano un rischio reale di incendio qualora siano in prossimità del prodotto.
5. Per pulire l'articolo usare solo acqua tiepida. Non usare solventi o derivati
6. **AVVERTENZA:** Non lasciare il bambino incostudito sul fasciatoio. Questo prodotto è adatto per bambini fino ai 15 kg di peso!
7. In caso di parti rotte, mancanti o graffiate, non utilizzare il prodotto. Si raccomanda l'utilizzo esclusivo di pezzi di ricambio originali forniti dal produttore.
8. Usi sempre un materassino per il fasciatoio, con uno spessore massimo di 40 mm di altezza sulla superficie del fasciatoio, in modo che esista sufficiente altezza restante per la sicurezza di caduta!

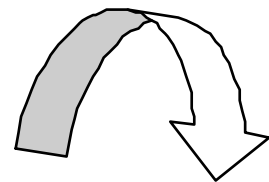

10

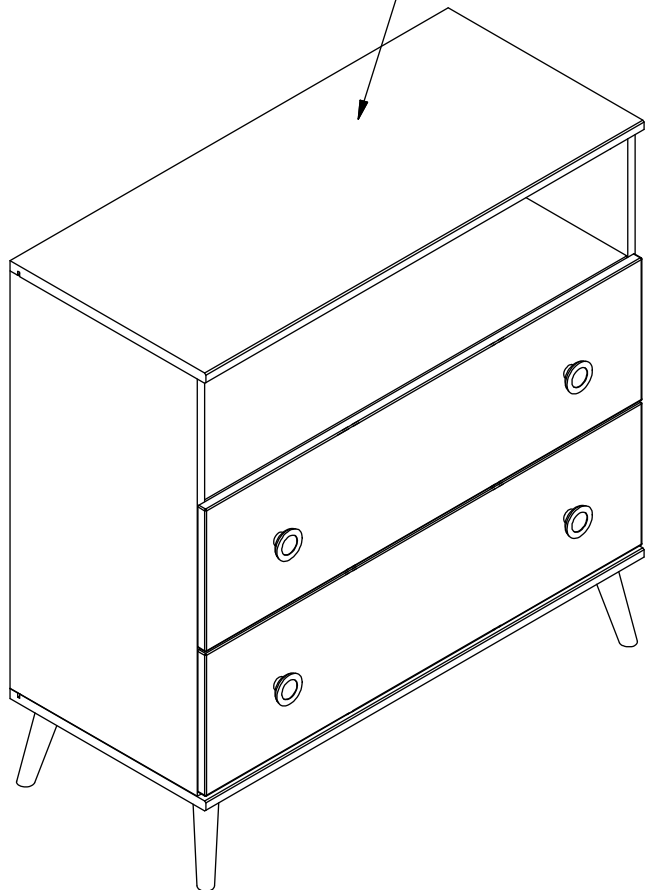

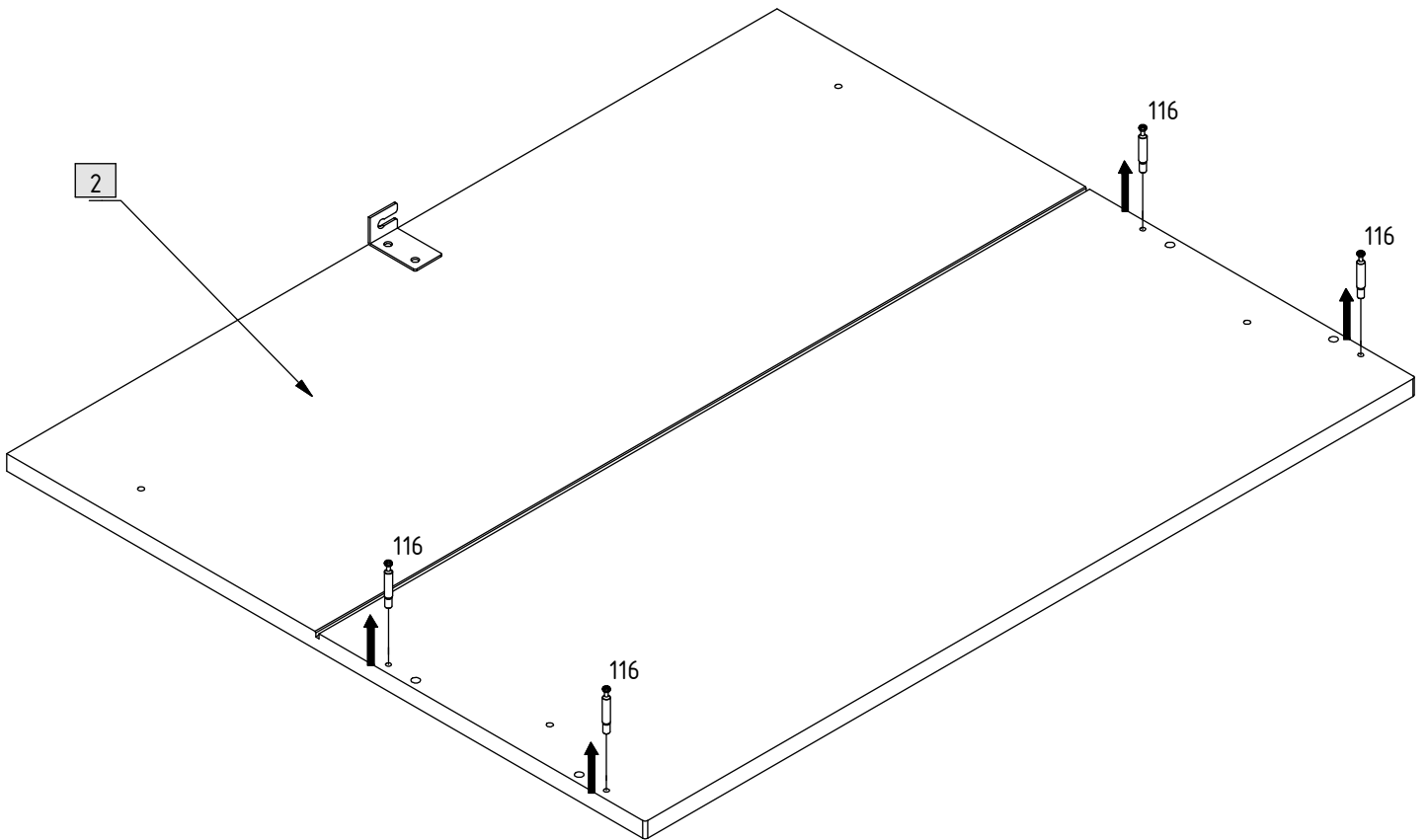
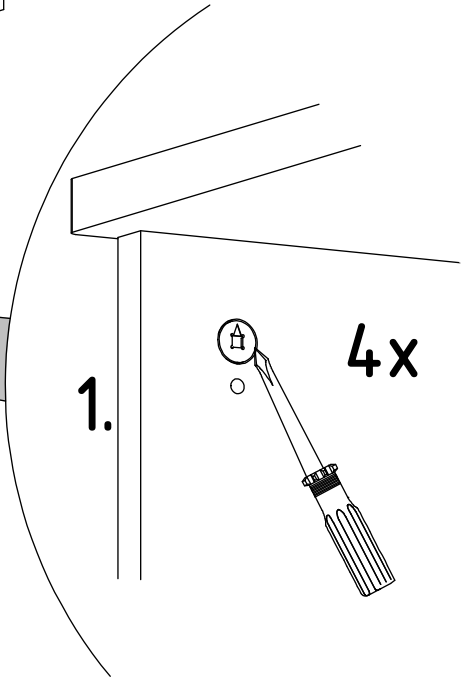
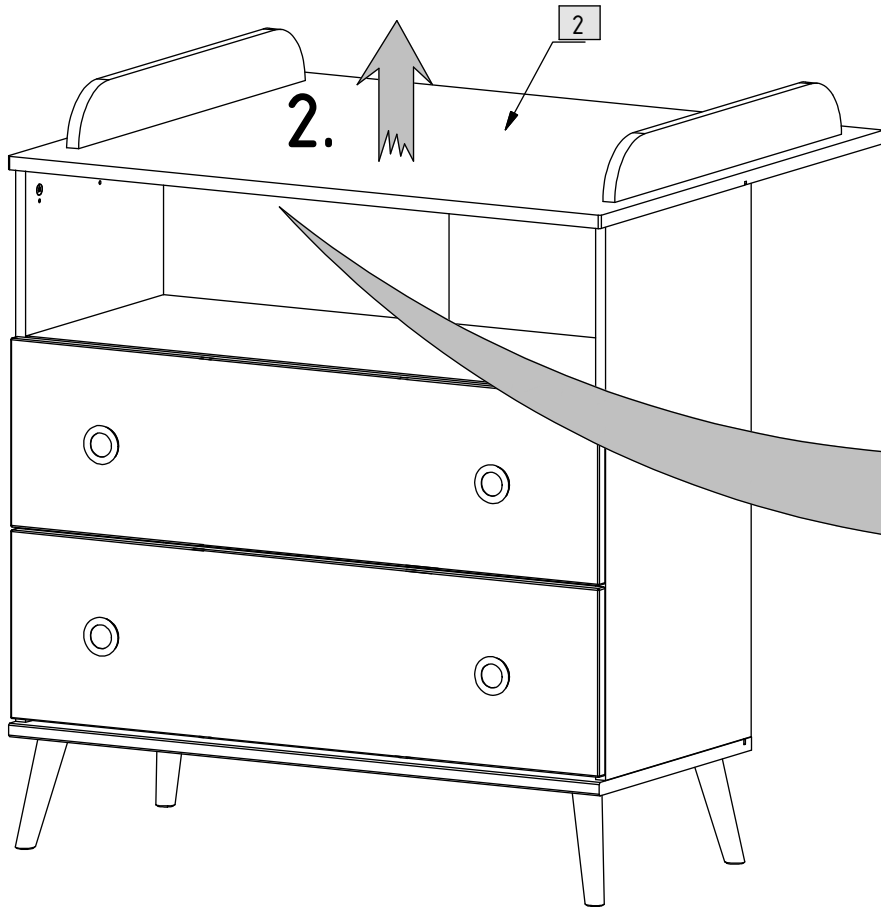

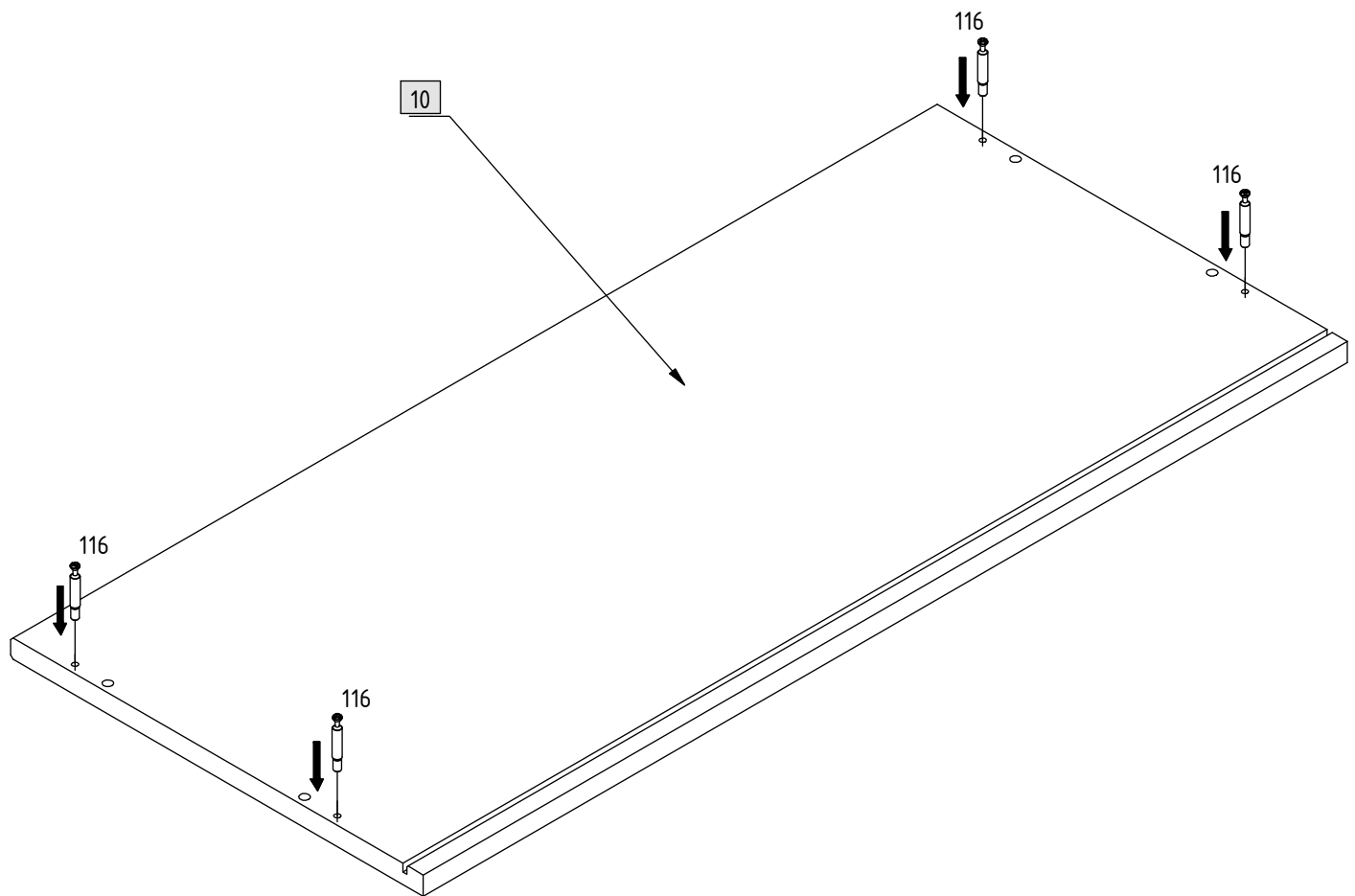

4x

