



Test Report issued under the responsibility of:



**TEST REPORT**  
**IEC 62368-1**  
**Audio/video, information and communication technology equipment**  
**Part 1: Safety requirements**

Report Number..... : CN22MKE6 001  
Date of issue..... : 2022-08-29  
Total number of pages..... : 83

Name of Testing Laboratory preparing the Report ..... : TÜV Rheinland (Guangdong) Ltd.

Applicant's name ..... : Jiangsu Chenyang Electron Co., Ltd.  
Address..... : No. 58 Chenyang Road, Hexi Industrial Park, Huangtang Town, Danyang City, 212364 Jiangsu, P. R. China

**Test specification:**

Standard..... : IEC 62368-1:2018  
Test procedure..... : CB Scheme  
Non-standard test method..... : N/A

TRF template used..... : IECEE OD-2020-F1:2021, Ed.1.4  
Test Report Form No..... : IEC62368\_1E  
Test Report Form(s) Originator ... : UL(US)  
Master TRF..... : Dated 2022-04-14

**Copyright © 2022 IEC System of Conformity Assessment Schemes for Electrotechnical Equipment and Components (IECEE System). All rights reserved.**

This publication may be reproduced in whole or in part for non-commercial purposes as long as the IECEE is acknowledged as copyright owner and source of the material. IECEE takes no responsibility for and will not assume liability for damages resulting from the reader's interpretation of the reproduced material due to its placement and context.



If this Test Report Form is used by non-IECEE members, the IECEE/IEC logo and the reference to the CB Scheme procedure shall be removed.

**This report is not valid as a CB Test Report unless signed by an approved CB Testing Laboratory and appended to a CB Test Certificate issued by an NCB in accordance with IECEE 02.**

**General disclaimer:**

The test results presented in this report relate only to the object tested.  
This report shall not be reproduced, except in full, without the written approval of the Issuing CB Testing Laboratory. The authenticity of this Test Report and its contents can be verified by contacting the NCB, responsible for this Test Report.

<b>Test item description</b> .....	AC POWER SUPPLY
<b>Trade Mark(s)</b> .....	
<b>Manufacturer</b> .....	Same as applicant
<b>Model/Type reference</b> .....	MC-681N, MC-682N, MC-683N, MC-685N, MC-686N, MC-687N, MC-689N
<b>Ratings</b> .....	Input: 100-240V~, 50/60Hz 2.0A  Output: 5.0V $\overline{=}$ 3.0A 15.0W or 9.0V $\overline{=}$ 3.0A 27.0W or 15.0V $\overline{=}$ 3.0A 45.0W or 20.0V $\overline{=}$ 3.4A 68.0W or 11.0V $\overline{=}$ 6.2A 68.2W MAX

<b>Responsible Testing Laboratory (as applicable), testing procedure and testing location(s):</b>		
<input checked="" type="checkbox"/>	<b>CB Testing Laboratory:</b>	<b>TÜV Rheinland (Guangdong) Ltd.</b>
<b>Testing location/ address..... :</b>		No.199 Kezhu Road, Guangzhou Science City 510663 Guangzhou, China
<b>Tested by (name, function, signature)..... :</b>		Spark Li Project Engineer 
<b>Approved by (name, function, signature) . :</b>		Liheng Hu Reviewer 
<hr/>		
<input type="checkbox"/>	<b>Testing procedure: CTF Stage 1:</b>	
<b>Testing location/ address..... :</b>		
<b>Tested by (name, function, signature)..... :</b>		
<b>Approved by (name, function, signature) . :</b>		
<hr/>		
<input type="checkbox"/>	<b>Testing procedure: CTF Stage 2:</b>	
<b>Testing location/ address..... :</b>		
<b>Tested by (name, function, signature).....</b>		
<b>Witnessed by (name, function, signature) :</b>		
<b>Approved by (name, function, signature) . :</b>		
<hr/>		
<input type="checkbox"/>	<b>Testing procedure: CTF Stage 3:</b>	
<input type="checkbox"/>	<b>Testing procedure: CTF Stage 4:</b>	
<b>Testing location/ address..... :</b>		
<b>Tested by (name, function, signature)..... :</b>		
<b>Witnessed by (name, function, signature) :</b>		
<b>Approved by (name, function, signature) . :</b>		
<b>Supervised by (name, function, signature):</b>		

**List of Attachments (including a total number of pages in each attachment):**

- Attachment 1: National differences (32 pages)
- Attachment 2: Plug portion test (47 pages)
- Attachment 3: Technical documentation (4 pages)
- Attachment 4: Photo documentation (20 pages)
- Attachment 5: IEC 62368-3 documentation (13 pages)

**Summary of testing:**
**Tests performed (name of test and test clause):**

All applicable tests as described in test case and measurement sections were performed.

4.7	Torque test
5.2	Electrical energy source classifications
5.3.2	Accessibility to electrical energy sources and safeguards (Accessibility test)
5.4.1.4, 9.3, B.1.5, B.2.6	Maximum operating temperatures for materials, components and systems
5.4.1.8	Determination of working voltage
5.4.1.10.3	Ball pressure test
5.4.2.2, 5.4.2.4 and 5.4.3	Clearance and creepage distance measurements
5.4.5	Surge test
5.4.8	Humidity conditioning
5.4.9	Electric strength test
5.5.2.2	Capacitor discharge
5.7.4	Unearthed accessible parts
6.2.2	Electrical power sources (PS) measurements for classification
6.3, 6.4	Simulated abnormal operating and single fault conditions
B.2.5	Input tests
B.3	Simulated abnormal operating condition tests
B.4	Simulated single fault conditions
F.3.9	Durability, legibility and permanence of markings
G.5.3.2	Transformer insulation
G.5.3.3	Transformer overload

**Testing location:**

**TÜV Rheinland (Guangdong) Ltd.**

No. 199 Kezhu Road, Guangzhou Science City 510663 Guangzhou, China

Q.1	Limited power sources
T.2	Steady force test, 10 N
T.4	Steady force test, 100 N
T.7	Drop test
T.8	Stress relief test

**Remark:**

The model MC-682N was selected for the tests.

Models MC-681N, MC-682N, MC-683N, MC-686N and MC-687N were selected for the plug test and Torque test.

**Summary of compliance with National Differences (List of countries addressed):**

List of countries addressed:

EU Group Differences, EU Special National Conditions

CA, DE, DK, FI, GB, IE, NO, SE, SG, US

Explanation of used codes: CA=Canada, DE=Germany, DK=Denmark, FI=Finland, GB= United Kingdom, IE=Ireland, NO=Norway, SE=Sweden, SG=Singapore, US=United States of America.

**The product fulfils the requirements of IEC 62368-1:2018, EN IEC 62368-1:2020.**

**Use of uncertainty of measurement for decisions on conformity (decision rule) :**

No decision rule is specified by the IEC standard, when comparing the measurement result with the applicable limit according to the specification in that standard. The decisions on conformity are made without applying the measurement uncertainty ("simple acceptance" decision rule, previously known as "accuracy method").

Other: ... (to be specified, for example when required by the standard or client, or if national accreditation requirements apply)

**Information on uncertainty of measurement:**

The uncertainties of measurement are calculated by the laboratory based on application of criteria given by OD-5014 for test equipment and application of test methods, decision sheets and operational procedures of IECEE.

IEC Guide 115 provides guidance on the application of measurement uncertainty principles and applying the decision rule when reporting test results within IECEE scheme, noting that the reporting of the measurement uncertainty for measurements is not necessary unless required by the test standard or customer.

Calculations leading to the reported values are on file with the NCB and testing laboratory that conducted the testing.

**Copy of marking plate:**

The artwork below may be only a draft. The use of certification marks on a product must be authorized by the respective NCBs that own these marks.

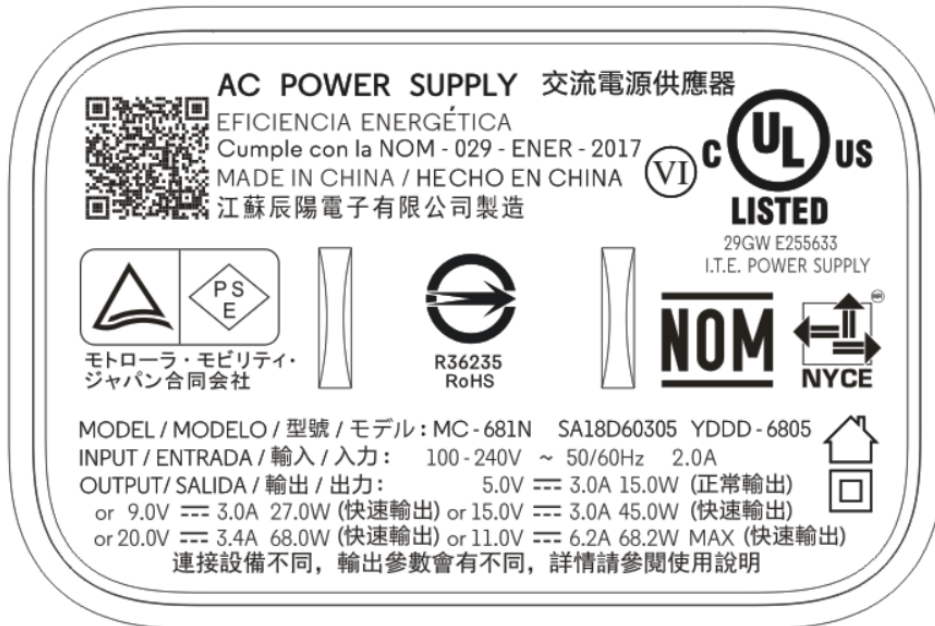

(Model: MC-681N)



(Model: MC-682N)

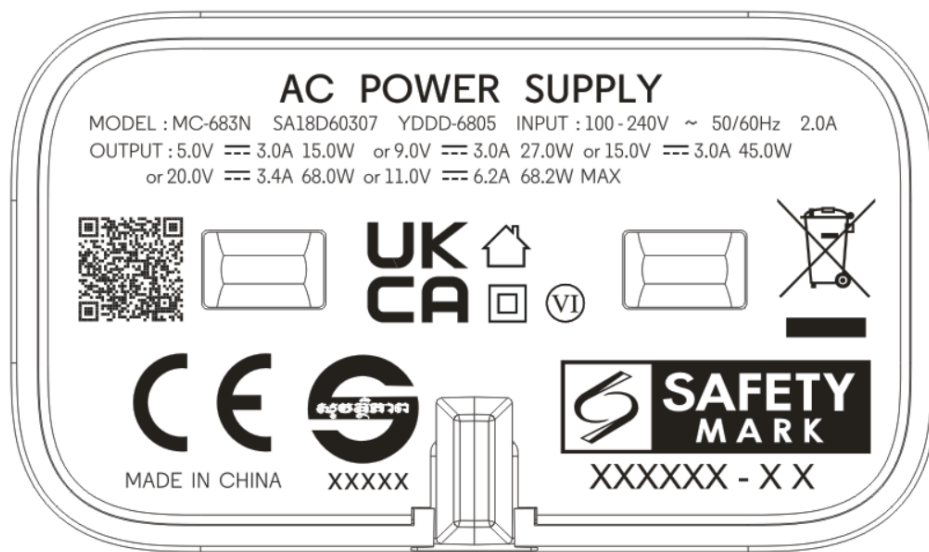

(MC-683N)

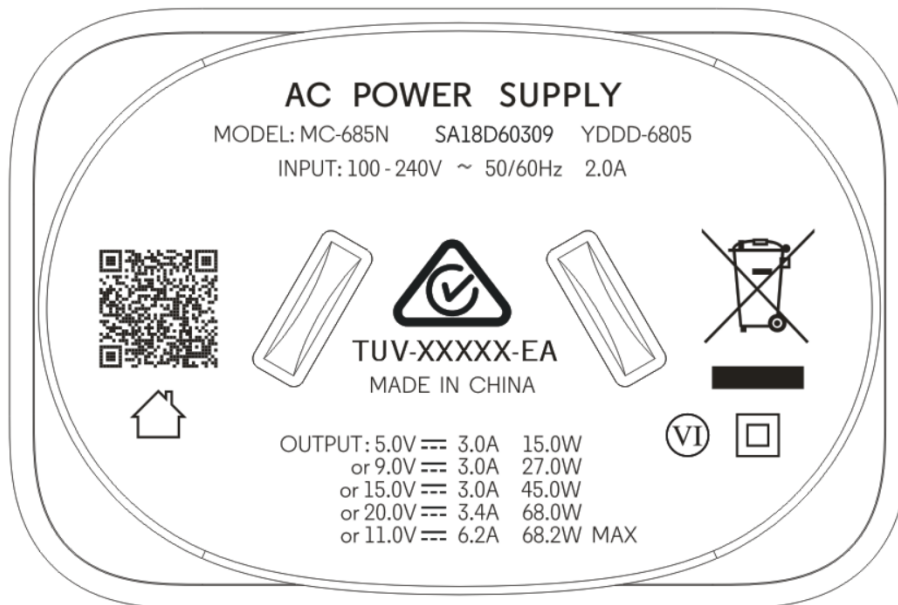

(Model: MC-685N)

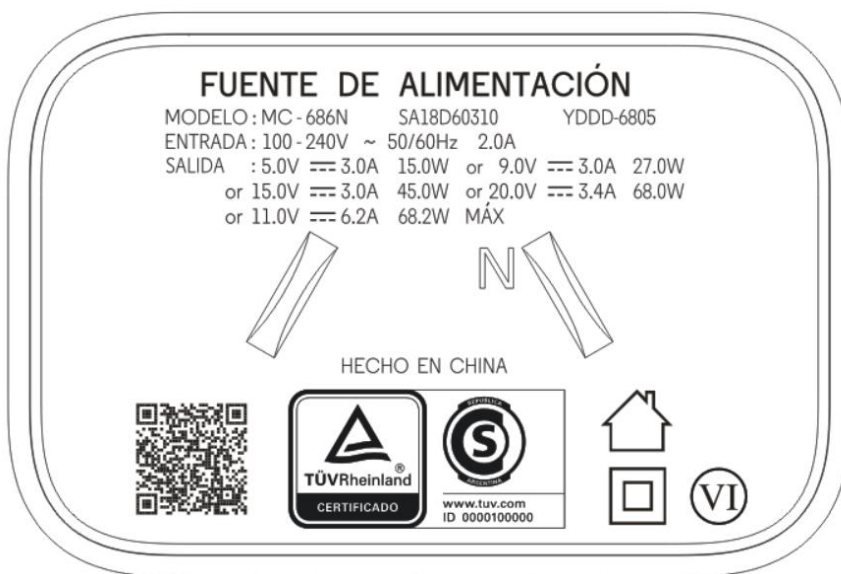

(Model: MC-686N)

**FONTE DE ALIMENTAÇÃO**

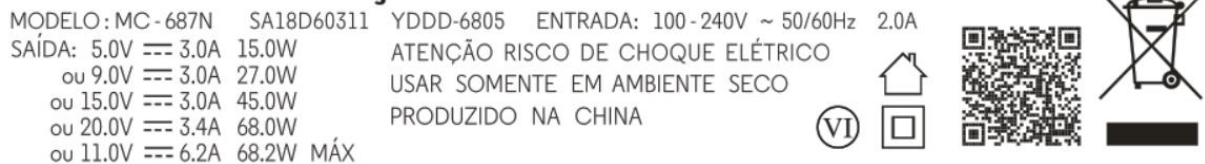

(Model: MC-687N)

**AC POWER SUPPLY / FUENTE DE ALIMENTACIÓN**



(Model: MC-689N)

Trademark: “” marked on the enclosure.

**Note:**

1. The above marking are the minimum requirements by the safety standard. For the final production samples, the additional markings which do not give rise to misunderstanding may be added.
2. The batch or serial number should be pasted to product before sell to EU market.
3. Manufacturer information (name/registered trademark/registered trade name and postal address) or importer information for manufacturer outside of the EU (name/registered trademark/registered trade name and postal address) should be pasted on product when sell the product to the EU market.



Test item particulars:	
<b>Product group</b> .....	<input checked="" type="checkbox"/> end product <input type="checkbox"/> built-in component
<b>Classification of use by</b> .....	<input checked="" type="checkbox"/> Ordinary person <input checked="" type="checkbox"/> Children likely present <input type="checkbox"/> Instructed person <input type="checkbox"/> Skilled person
<b>Supply connection</b> .....	<input checked="" type="checkbox"/> AC mains <input type="checkbox"/> DC mains <input type="checkbox"/> not mains connected: <input type="checkbox"/> ES1 <input type="checkbox"/> ES2 <input type="checkbox"/> ES3
<b>Supply tolerance</b> .....	<input checked="" type="checkbox"/> +10%/-10% <input type="checkbox"/> +20%/-15% <input type="checkbox"/> +        %/ -        % <input type="checkbox"/> None
<b>Supply connection – type</b> .....	<input checked="" type="checkbox"/> pluggable equipment type A - <input type="checkbox"/> non-detachable supply cord <input type="checkbox"/> appliance coupler <input checked="" type="checkbox"/> direct plug-in <input type="checkbox"/> pluggable equipment type B - <input type="checkbox"/> non-detachable supply cord <input type="checkbox"/> appliance coupler <input type="checkbox"/> permanent connection <input type="checkbox"/> mating connector <input type="checkbox"/> other:
<b>Considered current rating of protective device</b> .....	<input checked="" type="checkbox"/> 16 A (13A for UK, 20A for US and CSA); Location: <input checked="" type="checkbox"/> building <input type="checkbox"/> equipment <input type="checkbox"/> N/A
<b>Equipment mobility</b> .....	<input type="checkbox"/> movable <input type="checkbox"/> hand-held <input type="checkbox"/> transportable <input checked="" type="checkbox"/> direct plug-in <input type="checkbox"/> stationary <input type="checkbox"/> for building-in <input type="checkbox"/> wall/ceiling-mounted <input type="checkbox"/> SRME/rack-mounted <input type="checkbox"/> other:
<b>Overvoltage category (OVC)</b> .....	<input type="checkbox"/> OVC I <input checked="" type="checkbox"/> OVC II <input type="checkbox"/> OVC III <input type="checkbox"/> OVC IV <input type="checkbox"/> other:
<b>Class of equipment</b> .....	<input type="checkbox"/> Class I <input checked="" type="checkbox"/> Class II <input type="checkbox"/> Class III <input type="checkbox"/> Not classified <input type="checkbox"/>
<b>Special installation location</b> .....	<input checked="" type="checkbox"/> N/A <input type="checkbox"/> restricted access area <input type="checkbox"/> outdoor location <input type="checkbox"/>
<b>Pollution degree (PD)</b> .....	<input type="checkbox"/> PD 1 <input checked="" type="checkbox"/> PD 2 <input type="checkbox"/> PD 3
<b>Manufacturer's specified T<sub>ma</sub></b> .....	45 °C <input type="checkbox"/> Outdoor: minimum                      °C
<b>IP protection class</b> .....	<input type="checkbox"/> IPX0 <input checked="" type="checkbox"/> IP_20_
<b>Power systems</b> .....	<input checked="" type="checkbox"/> TN <input type="checkbox"/> TT <input type="checkbox"/> IT -                      V <sub>L-L</sub> <input type="checkbox"/> not AC mains
<b>Altitude during operation (m)</b> .....	<input type="checkbox"/> 2000 m or less <input checked="" type="checkbox"/> 5000 m
<b>Altitude of test laboratory (m)</b> .....	<input checked="" type="checkbox"/> 2000 m or less <input type="checkbox"/> m
<b>Mass of equipment (kg)</b> .....	0.092 kg max.

<b>Possible test case verdicts:</b> - test case does not apply to the test object...: N/A - test object does meet the requirement .....: P (Pass) - test object does not meet the requirement...: F (Fail)	
<b>Testing:</b> Date of receipt of test item .....: 2022-07-26 Date (s) of performance of tests.....: 2022-07-26 to 2022-08-26	
<b>General remarks:</b> "(See Enclosure #)" refers to additional information appended to the report. "(See appended table)" refers to a table appended to the report.  Throughout this report a <input type="checkbox"/> comma / <input checked="" type="checkbox"/> point is used as the decimal separator.	
<b>Manufacturer's Declaration per sub-clause 4.2.5 of IEC60335-1:</b>	
The application for obtaining a CB Test Certificate includes more than one factory location and a declaration from the Manufacturer stating that the sample(s) submitted for evaluation is (are) representative of the products from each factory has been provided.....:	<input type="checkbox"/> <b>Yes</b> <input checked="" type="checkbox"/> <b>Not applicable</b>
<b>When differences exist; they shall be identified in the General product information section.</b>	
<b>Name and address of factory (ies).....:</b> Same as applicant	
<b>General product information and other remarks:</b> 1. The equipment intended to use in information technology and audio/video equipment. 2. The adapter's top enclosure is secured to the bottom enclosure by ultrasonic welding. 3. Specified maximum ambient temperature is 45°C. 4. The test samples are pre-production sample without serial numbers. 5. The European plug portion was evaluated according to EN 50075:1990. The JP plug portion dimension was evaluated according to JIS C 8303:2007. The UK plug portion was evaluated according to BS 1363-1:2016 + A1:2018. The Saudi plug portion was evaluated according to SASO 2203:2018 (Partial). The AU plug portion dimension was evaluated according to AS/NZS 3112: 2017 + A1:2021. The AR plug portion dimension was evaluated according to IRAM 2063:2009. The BR plug portion dimension was evaluated according to NBR 14136. Details see attachment plug portion test report. Others shall be evaluated when national approval.	

6. For the output: 20.0V $\equiv$  3.4A 68.0W or 11.0V $\equiv$  6.2A 68.2W MAX,

the output power is the 68W or 68.2W (maintain 5 minutes) to 45W (maintain 5 minutes) to 33W(continue).

For the output: 15.0V $\equiv$ 3A 45.0W, the output power is the 45W (maintain 5 minutes) to 33W(continue).

7. The equipment was evaluated for a maximum operating altitude of 5000 m. therefore the requirements of IEC 62368-1 for clearances were considered and the required clearance was multiplied with an altitude correction factor of 1.48.

**Difference between models:**

All models are identical to each other except for the model name and plug portion.

**Model list:**

Model	Rated input	Rated Output	Plug type
MC-681N	100-240V~, 50/60Hz, 2.0A	5.0V $\equiv$ 3.0A 15.0W or 9.0V $\equiv$ 3.0A 27.0W or 15.0V $\equiv$ 3.0A 45.0W or 20.0V $\equiv$ 3.4A 68.0W or 11.0V $\equiv$ 6.2A 68.2W MAX	USA plug, JP plug
MC-682N			EU plug
MC-683N			UK plug, Saudi plug
MC-685N			AU plug
MC-686N			AR plug
MC-687N			BR plug
MC-689N			Chilean plug

<b>OVERVIEW OF ENERGY SOURCES AND SAFEGUARDS</b>				
<b>Clause</b>	<b>Possible Hazard</b>			
5	Electrically-caused injury			
Class and Energy Source (e.g. ES3: Primary circuit)	Body Part (e.g. Ordinary)	Safeguards		
		B	S	R
ES3: Primary circuits supplied by a.c. mains supply	Ordinary	N/A	N/A	Y-cap. see 5.5.2, transformer see 5.5.3, enclosure see 5.4.2, 5.4.3 and 5.4.4, Optocoupler see 5.5.4
ES3: Capacitor connected between L and N	Ordinary	N/A	N/A	See 5.5.2.2
ES1: Secondary output connector	Ordinary	N/A	N/A	N/A
6	Electrically-caused fire			
Class and Energy Source (e.g. PS2: 100 Watt circuit)	Material part (e.g. Printed board)	Safeguards		
		B	1 <sup>st</sup> S	2 <sup>nd</sup> S
PS3: All primary circuits inside the equipment enclosure	All combustible materials within equipment fire enclosure	Equipment safeguard (e.g., no ignition occurs)	Equipment safeguard (e.g., control of fire spread)	N/A
PS2: Secondary output connector	Connections of secondary equipment	Equipment safeguard (e.g., no ignition occurs)	N/A	N/A
7	Injury caused by hazardous substances			
Class and Energy Source (e.g. Ozone)	Body Part (e.g., Skilled)	Safeguards		
		B	S	R
N/A	N/A	N/A	N/A	N/A
8	Mechanically-caused injury			
Class and Energy Source (e.g. MS3: Plastic fan blades)	Body Part (e.g. Ordinary)	Safeguards		
		B	S	R
MS1: Mass of the unit	Ordinary	N/A	N/A	N/A
MS1: Edges and corners	Ordinary	N/A	N/A	N/A

9		Thermal burn		
Class and Energy Source (e.g. TS1: Keyboard caps)	Body Part (e.g., Ordinary)	Safeguards		
		B	S	R
TS1: Plastic enclosure	Ordinary	N/A	N/A	N/A
10		Radiation		
Class and Energy Source (e.g. RS1: PMP sound output)	Body Part (e.g., Ordinary)	Safeguards		
		B	S	R
N/A	N/A	N/A	N/A	N/A
Supplementary Information:				
"B" – Basic Safeguard; "S" – Supplementary Safeguard; "R" – Reinforced Safeguard				

**ENERGY SOURCE DIAGRAM**

**Optional.** Manufacturers are to provide the energy sources diagram identify declared energy sources and identifying the demarcations are between power sources. Recommend diagram be provided included in power supply and multipart systems.

Insert diagram below. Example diagram designs are; Block diagrams; image(s) with layered data; mechanical drawings

See above table

**ES3 (on the left side of T1), PS3 (on the left side of T1), enclosure surface is TS1**  
**ES1, PS2 (on the right side of T1 after Q2)**

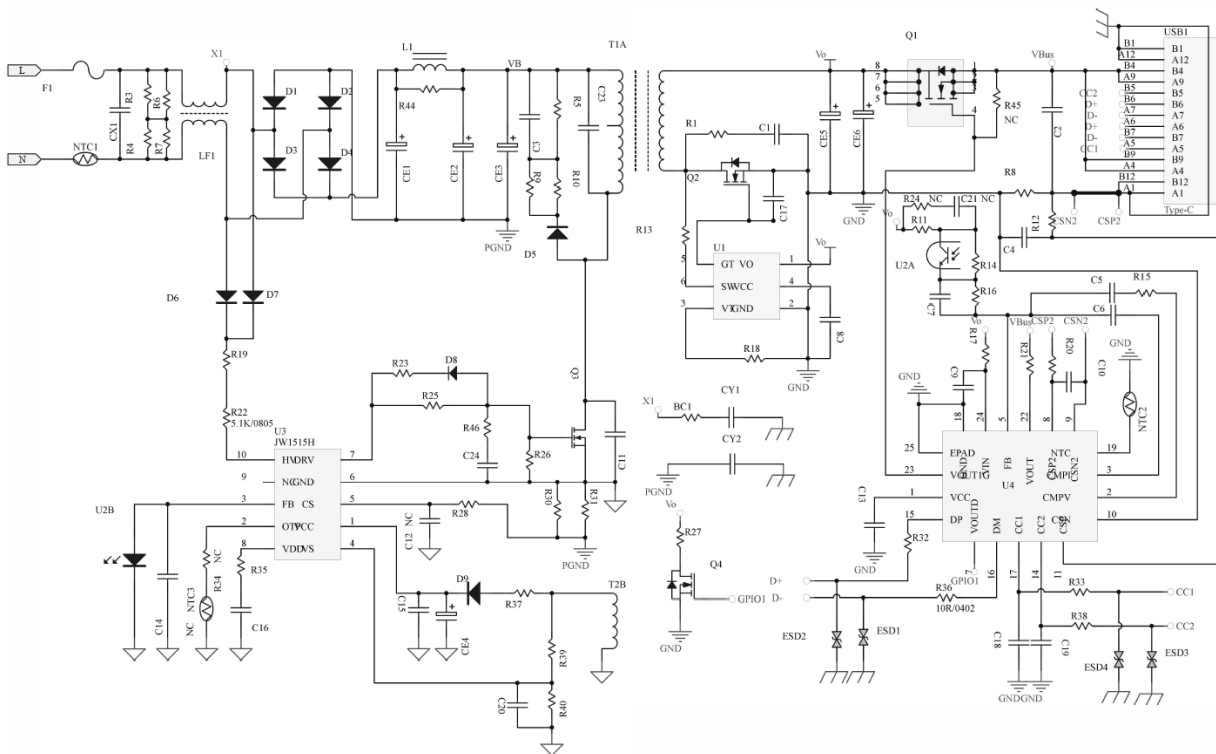

ES     PS     MS     TS     RS

IEC 62368-1			
Clause	Requirement + Test	Result - Remark	Verdict
<b>4</b>	<b>GENERAL REQUIREMENTS</b>		P
4.1.1	Acceptance of materials, components and subassemblies	See appended table 4.1.2	P
4.1.2	Use of components	Components which are certified to IEC and/or national standards are used correctly within their ratings. Components not covered by IEC standards are tested under the conditions present in the equipment. See also Annex G.	P
4.1.3	Equipment design and construction	Evaluation of safeguards regarding preventing access to ES3 parts, limiting the source supplying outputs to fulfill ES1, and protection in regard to risk of ignition, mechanical-caused injury and thermal burn considered.	P
4.1.4	Specified ambient temperature for outdoor use (°C) ..... :	Indoor use	N/A
4.1.5	Constructions and components not specifically covered		N/A
4.1.8	Liquids and liquid filled components (LFC)	(See G.15)	N/A
4.1.15	Markings and instructions	(See Annex F)	P
4.4.3	Safeguard robustness	See below.	P
4.4.3.1	General		P
4.4.3.2	Steady force tests	(See Annex T.2, T.4)	P
4.4.3.3	Drop tests	(See Annex T.7)	P
4.4.3.4	Impact tests	Direct plug in equipment	N/A
4.4.3.5	Internal accessible safeguard tests	The external enclosure cannot be opened without damaging the product.	N/A
4.4.3.6	Glass impact tests	(See Clause T.9, Annex U)	N/A
4.4.3.7	Glass fixation tests		N/A
	Glass impact test (1J)		N/A
	Push/pull test (10 N)		N/A
4.4.3.8	Thermoplastic material tests	(See Annex T.8)	P

IEC 62368-1			
Clause	Requirement + Test	Result - Remark	Verdict
4.4.3.9	Air comprising a safeguard	(See Annex T)	P
4.4.3.10	Accessibility, glass, safeguard effectiveness		P
4.4.4	Displacement of a safeguard by an insulating liquid		N/A
4.4.5	Safety interlocks	(See Annex K)	N/A
<b>4.5</b>	<b>Explosion</b>		P
4.5.1	General	(See Annex M for batteries)	N/A
4.5.2	No explosion during normal/abnormal operating condition	(See Clause B.2, B.3)	N/A
	No harm by explosion during single fault conditions	(See Clause B.4)	N/A
<b>4.6</b>	<b>Fixing of conductors</b>		P
	Fix conductors not to defeat a safeguard		P
	Compliance is checked by test ..... :	(See Clause T.2)	P
<b>4.7</b>	<b>Equipment for direct insertion into mains socket-outlets</b>		P
4.7.2	Mains plug part complies with relevant standard . :	See attachment plug test report for EU plug, JP plug, UK plug, Saudi plug, AU plug, AR plug and BR plug. Others shall be evaluated during national approval.	P
4.7.3	Torque (Nm) ..... :	Max. 0.029Nm (USA plug, JP plug) Max. 0.043Nm (EU plug) Max. 0.044Nm (BR plug) Max. 0.042Nm (UK plug, Saudi plug) Max. 0.031Nm (AU plug) Max. 0.031Nm (AR plug)	P
<b>4.8</b>	<b>Equipment containing coin/button cell batteries</b>		N/A
4.8.1	General	No coin cell.	N/A
4.8.2	Instructional safeguard..... :		N/A
4.8.3	Battery compartment door/cover construction		N/A
	Open torque test		N/A
4.8.4.2	Stress relief test		N/A
4.8.4.3	Battery replacement test		N/A
4.8.4.4	Drop test		N/A
4.8.4.5	Impact test		N/A
4.8.4.6	Crush test		N/A



IEC 62368-1			
Clause	Requirement + Test	Result - Remark	Verdict
4.8.5	Compliance		N/A
	30N force test with test probe		N/A
	20N force test with test hook		N/A
<b>4.9</b>	<b>Likelihood of fire or shock due to entry of conductive object</b>		P
<b>4.10</b>	<b>Component requirements</b>		P
4.10.1	Disconnect Device	(See Annex L)	P
4.10.2	Switches and relays	(See Annex G)	N/A

<b>5</b>	<b>ELECTRICALLY-CAUSED INJURY</b>		P
<b>5.2</b>	<b>Classification and limits of electrical energy sources</b>		P
5.2.2	ES1, ES2 and ES3 limits		P
5.2.2.2	Steady-state voltage and current limits .....	(See appended table 5.2)	P
5.2.2.3	Capacitance limits .....	(See appended table 5.2)	P
5.2.2.4	Single pulse limits.....	(See appended table 5.2)	N/A
5.2.2.5	Limits for repetitive pulses.....	(See appended table 5.2)	N/A
5.2.2.6	Ringling signals	(See Annex H)	N/A
5.2.2.7	Audio signals	No such audio signals	N/A
<b>5.3</b>	<b>Protection against electrical energy sources</b>		P
5.3.1	General Requirements for accessible parts to ordinary, instructed and skilled persons	See only 4.3 and 5.3 to 5.5 which applies to protection between the accessible parts and hazardous parts of other circuits.	P
5.3.1 a)	Accessible ES1/ES2 derived from ES2/ES3 circuits		N/A
5.3.1 b)	Skilled persons not unintentional contact ES3 bare conductors		N/A
5.3.2.1	Accessibility to electrical energy sources and safeguards	Only ES1 circuit can be accessed for this product.	P
	Accessibility to outdoor equipment bare parts		N/A
5.3.2.2	Contact requirements	No openings allowing entry of a probe. No access with test probe to any ES3 circuit or parts.	P
	Test with test probe from Annex V		—
5.3.2.2 a)	Air gap – electric strength test potential (V).....	(See appended table 5.4.9)	N/A
5.3.2.2 b)	Air gap – distance (mm) .....		N/A

IEC 62368-1			
Clause	Requirement + Test	Result - Remark	Verdict
5.3.2.3	Compliance		N/A
5.3.2.4	Terminals for connecting stripped wire		N/A
<b>5.4</b>	<b>Insulation materials and requirements</b>		<b>P</b>
5.4.1.2	Properties of insulating material	The choice and application have taken into account as specified in this Clause 5 and Annex T and natural rubber, hygroscopic materials or asbestos are not used as insulation.	P
5.4.1.3	Material is non-hygroscopic	Humidity conditioning test was conducted, refer to 5.4.8	P
5.4.1.4	Maximum operating temperature for insulating materials..... :	(See appended table 5.4.1.4)	P
5.4.1.5	Pollution degrees..... :	PD2	P
5.4.1.5.2	Test for pollution degree 1 environment and for an insulating compound		N/A
5.4.1.5.3	Thermal cycling test		N/A
5.4.1.6	Insulation in transformers with varying dimensions		N/A
5.4.1.7	Insulation in circuits generating starting pulses		N/A
5.4.1.8	Determination of working voltage..... :	(See appended table 5.4.1.8)	P
5.4.1.9	Insulating surfaces		P
5.4.1.10	Thermoplastic parts on which conductive metallic parts are directly mounted		P
5.4.1.10.2	Vicat test..... :	(See appended table 5.4.1.10.2)	N/A
5.4.1.10.3	Ball pressure test..... :	(See appended table 5.4.1.10.3)	P
5.4.2	Clearances	The highest value of 5.4.3.3 and 5.4.2.3 be used.	P
5.4.2.1	General requirements		P
	Clearances in circuits connected to AC Mains, Alternative method	(See Annex X)	N/A
5.4.2.2	Procedure 1 for determining clearance		N/A
	Temporary overvoltage ..... :		—
5.4.2.3	Procedure 2 for determining clearance		P
5.4.2.3.2.2	a.c. mains transient voltage..... :		—
5.4.2.3.2.3	d.c. mains transient voltage ..... :		—

IEC 62368-1			
Clause	Requirement + Test	Result - Remark	Verdict
5.4.2.3.2.4	External circuit transient voltage .....		—
5.4.2.3.2.5	Transient voltage determined by measurement....		—
5.4.2.4	Determining the adequacy of a clearance using an electric strength test .....	(See appended table 5.4.2)	N/A
5.4.2.5	Multiplication factors for clearances and test voltages .....	Up to 5000m, factor :1.48	P
5.4.2.6	Clearance measurement.....	(See appended table 5.4.2)	P
5.4.3	Creepage distances	(See appended table 5.4.2.2, 5.4.2.4 and 5.4.3)	P
5.4.3.1	General		P
5.4.3.3	Material group.....		—
5.4.3.4	Creepage distances measurement .....	(See appended table 5.4.3)	P
5.4.4	Solid insulation		P
5.4.4.1	General requirements		P
5.4.4.2	Minimum distance through insulation .....	(See appended table 5.4.4.2)	P
5.4.4.3	Insulating compound forming solid insulation	No insulation compound forming solid insulation other than optical isolator.	P
5.4.4.4	Solid insulation in semiconductor devices		P
5.4.4.5	Insulating compound forming cemented joints		N/A
5.4.4.6	Thin sheet material	Insulation tape	P
5.4.4.6.1	General requirements		P
5.4.4.6.2	Separable thin sheet material	Reinforced insulation consisting of two layers of tape, each layer shall pass the electric strength test for reinforced insulation.	P
	Number of layers (pcs) .....	2	P
5.4.4.6.3	Non-separable thin sheet material		N/A
	Number of layers (pcs) .....		N/A
5.4.4.6.4	Standard test procedure for non-separable thin sheet material.....	(See appended table 5.4.9)	N/A
5.4.4.6.5	Mandrel test		N/A
5.4.4.7	Solid insulation in wound components	See G.5.3 and G.6.1 only.	P
5.4.4.9	Solid insulation at frequencies >30 kHz, $E_p$ , $K_R$ , $d$ , $V_{PW}$ (V).....	(See appended Table 5.4.4.9)	P

IEC 62368-1			
Clause	Requirement + Test	Result - Remark	Verdict
	Alternative by electric strength test, tested voltage (V), $K_R$ .....	(See appended Tables 5.4.4.9 and 5.4.9)	P
5.4.5	Antenna terminal insulation		P
5.4.5.1	General		P
5.4.5.2	Voltage surge test		P
5.4.5.3	Insulation resistance ( $M\Omega$ )..... :	Input to output: >100 $M\Omega$	P
	Electric strength test..... :	(See appended table 5.4.9)	P
5.4.6	Insulation of internal wire as part of supplementary safeguard		N/A
5.4.7	Tests for semiconductor components and for cemented joints		N/A
5.4.8	Humidity conditioning	All source of insulation sheet, plastic material for enclosure and insulation tape listed in table 4.1.2. were considered	P
	Relative humidity (%), temperature ( $^{\circ}C$ ), duration (h) .....	95%, 40 $^{\circ}C$ , 120 h.	—
5.4.9	Electric strength test	(See appended table 5.4.9)	P
5.4.9.1	Test procedure for type test of solid insulation .... :	(See appended table 5.4.9)	P
5.4.9.2	Test procedure for routine test	Should be considered and conducted during production at factory.	N/A
5.4.10	Safeguards against transient voltages from external circuits	No connection to external circuits with transient voltage.	N/A
5.4.10.1	Parts and circuits separated from external circuits		N/A
5.4.10.2	Test methods		N/A
5.4.10.2.1	General		N/A
5.4.10.2.2	Impulse test .....	(See appended table 5.4.9)	N/A
5.4.10.2.3	Steady-state test..... :	(See appended table 5.4.9)	N/A
5.4.10.3	Verification for insulation breakdown for impulse test .....		N/A
5.4.11	Separation between external circuits and earth		N/A
5.4.11.1	Exceptions to separation between external circuits and earth	No such external circuit.	N/A
5.4.11.2	Requirements		N/A
	SPDs bridge separation between external circuit and earth		N/A

IEC 62368-1			
Clause	Requirement + Test	Result - Remark	Verdict
	Rated operating voltage $U_{op}$ (V) .....		—
	Nominal voltage $U_{peak}$ (V) .....		—
	Max increase due to variation $\Delta U_{sp}$ .....		—
	Max increase due to ageing $\Delta U_{sa}$ .....		—
5.4.11.3	Test method and compliance .....	(See appended table 5.4.9)	N/A
5.4.12	Insulating liquid		N/A
5.4.12.1	General requirements		N/A
5.4.12.2	Electric strength of an insulating liquid.....	(See appended table 5.4.9)	N/A
5.4.12.3	Compatibility of an insulating liquid .....	(See appended table 5.4.9)	N/A
5.4.12.4	Container for insulating liquid .....		N/A
<b>5.5</b>	<b>Components as safeguards</b>		<b>P</b>
5.5.1	General		<b>P</b>
5.5.2	Capacitors and RC units	Approved X, Y capacitor provided. See G.11.1.	<b>P</b>
5.5.2.1	General requirement		<b>P</b>
5.5.2.2	Safeguards against capacitor discharge after disconnection of a connector .....	(See appended table 5.5.2.2)	<b>P</b>
5.5.3	Transformers	(See Annex G.5.3)	<b>P</b>
5.5.4	Optocouplers	Approved Optocoupler used.	<b>P</b>
5.5.5	Relays	(See sub-clause 5.4)	N/A
5.5.6	Resistors		N/A
5.5.7	SPDs	(See Clause G.8)	N/A
5.5.8	Insulation between the mains and an external circuit consisting of a coaxial cable .....		N/A
5.5.9	Safeguards for socket-outlets in outdoor equipment		N/A
	RCD rated residual operating current (mA) .....		—
<b>5.6</b>	<b>Protective conductor</b>		<b>N/A</b>
5.6.2	Requirement for protective conductors		N/A
<b>5.6</b>	<b>Protective conductor</b>		<b>N/A</b>
5.6.2	Requirement for protective conductors		N/A
5.6.2.1	General requirements		N/A
5.6.2.2	Colour of insulation		N/A
5.6.3	Requirement for protective earthing conductors		N/A
	Protective earthing conductor size (mm <sup>2</sup> ) .....		—

IEC 62368-1			
Clause	Requirement + Test	Result - Remark	Verdict
	Protective earthing conductor serving as a reinforced safeguard		N/A
	Protective earthing conductor serving as a double safeguard		N/A
5.6.4	Requirements for protective bonding conductors		N/A
5.6.4.1	Protective bonding conductors		N/A
	Protective bonding conductor size (mm <sup>2</sup> ). ..... :		—
5.6.4.2	Protective current rating (A)..... :		N/A
5.6.5	Terminals for protective conductors		N/A
5.6.5.1	Terminal size for connecting protective earthing conductors (mm)..... :		N/A
	Terminal size for connecting protective bonding conductors (mm) ..... :		N/A
5.6.5.2	Corrosion		N/A
5.6.6	Resistance of the protective bonding system		N/A
5.6.6.1	Requirements		N/A
5.6.6.2	Test Method ..... :	(See appended table 5.6.6)	N/A
5.6.6.3	Resistance ( $\Omega$ ) or voltage drop ..... :	(See appended table 5.6.6)	N/A
5.6.7	Reliable connection of a protective earthing conductor		N/A
5.6.8	Functional earthing		N/A
	Conductor size (mm <sup>2</sup> )..... :		N/A
	Class II with functional earthing marking ..... :		N/A
	Appliance inlet cl & cr (mm) ..... :		N/A
<b>5.7</b>	<b>Prospective touch voltage, touch current and protective conductor current</b>		<b>P</b>
5.7.2	Measuring devices and networks		P
5.7.2.1	Measurement of touch current		P
5.7.2.2	Measurement of voltage		P
5.7.3	Equipment set-up, supply connections and earth connections		P
5.7.4	Unearthed accessible parts ..... :	(See appended table 5.7.4)	P
5.7.5	Earthed accessible conductive parts ..... :	(See appended table 5.7.5)	N/A
5.7.6	Requirements when touch current exceeds ES2 limits		N/A
	Protective conductor current (mA) ..... :		N/A

IEC 62368-1			
Clause	Requirement + Test	Result - Remark	Verdict
	Instructional Safeguard .....		N/A
5.7.7	Prospective touch voltage and touch current associated with external circuits		N/A
5.7.7.1	Touch current from coaxial cables		N/A
5.7.7.2	Prospective touch voltage and touch current associated with paired conductor cables		N/A
5.7.8	Summation of touch currents from external circuits		N/A
	a) Equipment connected to earthed external circuits, current (mA) .....		N/A
	b) Equipment connected to unearthed external circuits, current (mA) .....		N/A
<b>5.8</b>	<b>Backfeed safeguard in battery backed up supplies</b>		N/A
	Mains terminal ES .....	(See appended table 5.8)	N/A
	Air gap (mm).....		N/A

<b>6</b>	<b>ELECTRICALLY- CAUSED FIRE</b>		P
<b>6.2</b>	<b>Classification of PS and PIS</b>		P
6.2.2	Power source circuit classifications .....	(See appended table 6.2.2)	P
6.2.3	Classification of potential ignition sources		P
6.2.3.1	Arcing PIS .....	(See appended table 6.2.3.1)	P
6.2.3.2	Resistive PIS .....	(See appended table 6.2.3.2)	P
<b>6.3</b>	<b>Safeguards against fire under normal operating and abnormal operating conditions</b>		P
6.3.1	No ignition and attainable temperature value less than 90 % defined by ISO 871 or less than 300 °C for unknown materials.....	(See appended table B.1.5 and B.3, B.4)	P
	Combustible materials outside fire enclosure .....		N/A
<b>6.4</b>	<b>Safeguards against fire under single fault conditions</b>		P
6.4.1	Safeguard method	Method by control of fire spread applied, Fire enclosure provided.	P
6.4.2	Reduction of the likelihood of ignition under single fault conditions in PS1 circuits		N/A
6.4.3	Reduction of the likelihood of ignition under single fault conditions in PS2 and PS3 circuits		N/A
6.4.3.1	Supplementary safeguards		N/A
6.4.3.2	Single Fault Conditions.....	(See appended table B.4)	N/A

IEC 62368-1			
Clause	Requirement + Test	Result - Remark	Verdict
	Special conditions for temperature limited by fuse		N/A
6.4.4	Control of fire spread in PS1 circuits		N/A
6.4.5	Control of fire spread in PS2 circuits	Compliance detailed as follows: – <u>Printed board</u> : rated min. V-0 – <u>All other components</u> : at least V-2 except for mounted on min. V-1 material or small parts of combustible material.  <u>Isolating transformer</u> : complying with G.5.3.	P
6.4.5.2	Supplementary safeguards		P
6.4.6	Control of fire spread in PS3 circuits	Compliance detailed as follows: – <u>Printed board</u> : rated min. V-1 or better – <u>Wire insulation (tubing)</u> : complying with Clause 6 (See Table 4.1.2 for wiring used). – <u>All other components</u> : at least V-2 except for mounted on min. V-1 material or small parts of combustible material.  <u>Isolating transformer</u> : complying with G.5.3.	P
6.4.7	Separation of combustible materials from a PIS		N/A
6.4.7.2	Separation by distance		N/A
6.4.7.3	Separation by a fire barrier		N/A
6.4.8	Fire enclosures and fire barriers	See below.	P
6.4.8.2	Fire enclosure and fire barrier material properties	The V-0 material is used for the fire enclosure (overall enclosure).	P
6.4.8.2.1	Requirements for a fire barrier	No fire barrier.	N/A
6.4.8.2.2	Requirements for a fire enclosure	The V-0 fire enclosure is used. See above.	P



IEC 62368-1			
Clause	Requirement + Test	Result - Remark	Verdict
6.4.8.3	Constructional requirements for a fire enclosure and a fire barrier		P
6.4.8.3.1	Fire enclosure and fire barrier openings	No Fire enclosure opening	P
6.4.8.3.2	Fire barrier dimensions	No fire barrier	N/A
6.4.8.3.3	Top openings and properties		N/A
	Openings dimensions (mm)..... :		N/A
6.4.8.3.4	Bottom openings and properties		N/A
	Openings dimensions (mm)..... :		N/A
	Flammability tests for the bottom of a fire enclosure	(See Clause S.3)	N/A
	Instructional Safeguard..... :		N/A
6.4.8.3.5	Side openings and properties		N/A
	Openings dimensions (mm)..... :		N/A
6.4.8.3.6	Integrity of a fire enclosure, condition met: a), b) or c)..... :		N/A
6.4.8.4	Separation of a PIS from a fire enclosure and a fire barrier distance (mm) or flammability rating..... :	Fire enclosure material V-0 min.	P
6.4.9	Flammability of insulating liquid..... :		N/A
<b>6.5</b>	<b>Internal and external wiring</b>		P
6.5.1	General requirements		P
6.5.2	Requirements for interconnection to building wiring..... :		N/A
6.5.3	Internal wiring size (mm <sup>2</sup> ) for socket-outlets..... :	See table 4.1.2	P
<b>6.6</b>	<b>Safeguards against fire due to the connection to additional equipment</b>		P

<b>7</b>	<b>INJURY CAUSED BY HAZARDOUS SUBSTANCES</b>		N/A
<b>7.2</b>	<b>Reduction of exposure to hazardous substances</b>		N/A
<b>7.3</b>	<b>Ozone exposure</b>		N/A
<b>7.4</b>	<b>Use of personal safeguards or personal protective equipment (PPE)</b>		N/A
	Personal safeguards and instructions..... :		—
<b>7.5</b>	<b>Use of instructional safeguards and instructions</b>		N/A
	Instructional safeguard (ISO 7010)..... :		—
<b>7.6</b>	<b>Batteries and their protection circuits</b>		N/A

<b>8</b>	<b>MECHANICALLY-CAUSED INJURY</b>		P
----------	-----------------------------------	--	---

IEC 62368-1			
Clause	Requirement + Test	Result - Remark	Verdict
<b>8.2</b>	<b>Mechanical energy source classifications</b>		P
<b>8.3</b>	<b>Safeguards against mechanical energy sources</b>		N/A
<b>8.4</b>	<b>Safeguards against parts with sharp edges and corners</b>		P
8.4.1	Safeguards		N/A
	Instructional Safeguard..... :		N/A
8.4.2	Sharp edges or corners		N/A
<b>8.5</b>	<b>Safeguards against moving parts</b>		N/A
8.5.1	Fingers, jewellery, clothing, hair, etc., contact with MS2 or MS3 parts		N/A
	MS2 or MS3 part required to be accessible for the function of the equipment		N/A
	Moving MS3 parts only accessible to skilled person		N/A
8.5.2	Instructional safeguard .....		N/A
8.5.4	Special categories of equipment containing moving parts		N/A
8.5.4.1	General		N/A
8.5.4.2	Equipment containing work cells with MS3 parts		N/A
8.5.4.2.1	Protection of persons in the work cell		N/A
8.5.4.2.2	Access protection override		N/A
8.5.4.2.2.1	Override system		N/A
8.5.4.2.2.2	Visual indicator		N/A
8.5.4.2.3	Emergency stop system		N/A
	Maximum stopping distance from the point of activation (m)..... :		N/A
	Space between end point and nearest fixed mechanical part (mm)..... :		N/A
8.5.4.2.4	Endurance requirements		N/A
	Mechanical system subjected to 100 000 cycles of operation		N/A
	- Mechanical function check and visual inspection		N/A
	- Cable assembly .....		N/A
8.5.4.3	Equipment having electromechanical device for destruction of media		N/A
8.5.4.3.1	Equipment safeguards		N/A
8.5.4.3.2	Instructional safeguards against moving parts..... :		N/A

IEC 62368-1			
Clause	Requirement + Test	Result - Remark	Verdict
8.5.4.3.3	Disconnection from the supply		N/A
8.5.4.3.4	Cut type and test force (N) .....		N/A
8.5.4.3.5	Compliance		N/A
8.5.5	High pressure lamps		N/A
	Explosion test .....		N/A
8.5.5.3	Glass particles dimensions (mm) .....		N/A
<b>8.6</b>	<b>Stability of equipment</b>		
8.6.1	General		N/A
	Instructional safeguard .....		N/A
8.6.2	Static stability		N/A
8.6.2.2	Static stability test .....		N/A
8.6.2.3	Downward force test		N/A
8.6.3	Relocation stability		N/A
	Wheels diameter (mm) .....		—
	Tilt test		N/A
8.6.4	Glass slide test		N/A
8.6.5	Horizontal force test .....		N/A
<b>8.7</b>	<b>Equipment mounted to wall, ceiling or other structure</b>		N/A
8.7.1	Mount means type .....		N/A
8.7.2	Test methods		N/A
	Test 1, additional downwards force (N) .....		N/A
	Test 2, number of attachment points and test force (N) .....		N/A
	Test 3 Nominal diameter (mm) and applied torque (Nm) .....		N/A
<b>8.8</b>	<b>Handles strength</b>		N/A
8.8.1	General		N/A
8.8.2	Handle strength test		N/A
	Number of handles .....		—
	Force applied (N) .....		—
<b>8.9</b>	<b>Wheels or casters attachment requirements</b>		
8.9.2	Pull test		N/A
<b>8.10</b>	<b>Carts, stands and similar carriers</b>		N/A

IEC 62368-1			
Clause	Requirement + Test	Result - Remark	Verdict
8.10.1	General		N/A
8.10.2	Marking and instructions .....		N/A
8.10.3	Cart, stand or carrier loading test		N/A
	Loading force applied (N) .....		N/A
8.10.4	Cart, stand or carrier impact test		N/A
8.10.5	Mechanical stability		N/A
	Force applied (N).....		N/A
8.10.6	Thermoplastic temperature stability		N/A
<b>8.11</b>	<b>Mounting means for slide-rail mounted equipment (SRME)</b>		N/A
8.11.1	General		N/A
8.11.2	Requirements for slide rails		N/A
	Instructional Safeguard.....		N/A
8.11.3	Mechanical strength test		N/A
8.11.3.1	Downward force test, force (N) applied .....		N/A
8.11.3.2	Lateral push force test		N/A
8.11.3.3	Integrity of slide rail end stops		N/A
8.11.4	Compliance		N/A
<b>8.12</b>	<b>Telescoping or rod antennas</b>		N/A
	Button/ball diameter (mm) .....		—

<b>9</b>	<b>THERMAL BURN INJURY</b>		P
<b>9.2</b>	<b>Thermal energy source classifications</b>		P
<b>9.3</b>	<b>Touch temperature limits</b>		P
9.3.1	Touch temperatures of accessible parts.....	(See appended table)	P
9.3.2	Test method and compliance		P
<b>9.4</b>	<b>Safeguards against thermal energy sources</b>		P
<b>9.5</b>	<b>Requirements for safeguards</b>		P
9.5.1	Equipment safeguard	Equipment safeguard	P
9.5.2	Instructional safeguard .....	Instructional safeguard is not required	N/A
<b>9.6</b>	<b>Requirements for wireless power transmitters</b>		N/A
9.6.1	General		N/A
9.6.2	Specification of the foreign objects		N/A

IEC 62368-1			
Clause	Requirement + Test	Result - Remark	Verdict
9.6.3	Test method and compliance..... :	(See appended table 9.6)	N/A

<b>10</b>	<b>RADIATION</b>		N/A
<b>10.2</b>	<b>Radiation energy source classification</b>		N/A
10.2.1	General classification		N/A
	Lasers .....		—
	Lamps and lamp systems..... :		—
	Image projectors .....		—
	X-Ray .....		—
	Personal music player .....		—
<b>10.3</b>	<b>Safeguards against laser radiation</b>		N/A
	The standard(s) equipment containing laser(s) comply .....		N/A
<b>10.4</b>	<b>Safeguards against optical radiation from lamps and lamp systems (including LED types)</b>		N/A
10.4.1	General requirements		N/A
	Instructional safeguard provided for accessible radiation level needs to exceed		N/A
	Risk group marking and location .....		N/A
	Information for safe operation and installation		N/A
10.4.2	Requirements for enclosures		N/A
	UV radiation exposure..... :	(See Annex C)	N/A
10.4.3	Instructional safeguard..... :		N/A
<b>10.5</b>	<b>Safeguards against X-radiation</b>		
10.5.1	Requirements		N/A
	Instructional safeguard for skilled persons .....		—
10.5.3	Maximum radiation (pA/kg)..... :	(See appended tables B.3 & B.4)	—
<b>10.6</b>	<b>Safeguards against acoustic energy sources</b>		N/A
10.6.1	General		N/A
10.6.2	Classification		N/A
	Acoustic output $L_{Aeq,T}$ , dB(A)..... :		N/A
	Unweighted RMS output voltage (mV)..... :		N/A
	Digital output signal (dBFS)..... :		N/A

IEC 62368-1			
Clause	Requirement + Test	Result - Remark	Verdict
10.6.3	Requirements for dose-based systems		N/A
10.6.3.1	General requirements		N/A
10.6.3.2	Dose-based warning and automatic decrease		N/A
10.6.3.3	Exposure-based warning and requirements		N/A
	30 s integrated exposure level (MEL30)..... :		N/A
	Warning for MEL $\geq$ 100 dB(A)..... :		N/A
10.6.4	Measurement methods		N/A
10.6.5	Protection of persons		N/A
	Instructional safeguards..... :		N/A
10.6.6	Requirements for listening devices (headphones, earphones, etc.)		N/A
10.6.6.1	Corded listening devices with analogue input		N/A
	Listening device input voltage (mV)..... :		N/A
10.6.6.2	Corded listening devices with digital input		N/A
	Max. acoustic output $L_{Aeq,T}$ , dB(A)..... :		N/A
10.6.6.3	Cordless listening devices		N/A
	Max. acoustic output $L_{Aeq,T}$ , dB(A)..... :		N/A

<b>B</b>	<b>NORMAL OPERATING CONDITION TESTS, ABNORMAL OPERATING CONDITION TESTS AND SINGLE FAULT CONDITION TESTS</b>		P
<b>B.1</b>	<b>General</b>		P
B.1.5	Temperature measurement conditions	(See appended table B.1.5)	P
<b>B.2</b>	<b>Normal operating conditions</b>		P
B.2.1	General requirements..... :	(See Test Item Particulars and appended test tables)	P
	Audio Amplifiers and equipment with audio amplifiers..... :	(See Annex E)	N/A
B.2.3	Supply voltage and tolerances	Rated voltage $\pm$ 10 %	P
B.2.5	Input test..... :	(See appended table B.2.5)	P
<b>B.3</b>	<b>Simulated abnormal operating conditions</b>		P
B.3.1	General		P
B.3.2	Covering of ventilation openings		N/A
	Instructional safeguard..... :		N/A

IEC 62368-1			
Clause	Requirement + Test	Result - Remark	Verdict
B.3.3	DC mains polarity test	The EUT is not connected to a D.C. mains	N/A
B.3.4	Setting of voltage selector	No voltage selector was used.	N/A
B.3.5	Maximum load at output terminals	(See appended table B.3, B.4)	P
B.3.6	Reverse battery polarity		N/A
B.3.7	Audio amplifier abnormal operating conditions		N/A
B.3.8	Safeguards functional during and after abnormal operating conditions .....	All safeguards remained effective	P
<b>B.4</b>	<b>Simulated single fault conditions</b>		P
B.4.1	General		P
B.4.2	Temperature controlling device	No such device used.	N/A
B.4.3	Blocked motor test	No motors used.	N/A
B.4.4	Functional insulation	(See appended table B.3, B.4)	P
B.4.4.1	Short circuit of clearances for functional insulation	(See appended table B.3, B.4)	P
B.4.4.2	Short circuit of creepage distances for functional insulation	(See appended table B.3, B.4)	P
B.4.4.3	Short circuit of functional insulation on coated printed boards		N/A
B.4.5	Short-circuit and interruption of electrodes in tubes and semiconductors	(See appended table B.3, B.4)	P
B.4.6	Short circuit or disconnection of passive components	(See appended table B.3, B.4)	P
B.4.7	Continuous operation of components	The EUT is continuous operating type and no such components intended for short time operation or intermittent operation	N/A
B.4.8	Compliance during and after single fault conditions .....	(See appended table B.3, B.4)	P
B.4.9	Battery charging and discharging under single fault conditions	(See Annex M)	N/A
<b>C</b>	<b>UV RADIATION</b>		N/A
<b>C.1</b>	<b>Protection of materials in equipment from UV radiation</b>		N/A
C.1.2	Requirements		N/A
C.1.3	Test method		N/A
<b>C.2</b>	<b>UV light conditioning test</b>		N/A
C.2.1	Test apparatus .....		N/A

IEC 62368-1			
Clause	Requirement + Test	Result - Remark	Verdict
C.2.2	Mounting of test samples		N/A
C.2.3	Carbon-arc light-exposure test		N/A
C.2.4	Xenon-arc light-exposure test		N/A
<b>D</b>	<b>TEST GENERATORS</b>		<b>P</b>
<b>D.1</b>	<b>Impulse test generators</b>		<b>N/A</b>
<b>D.2</b>	<b>Antenna interface test generator</b>		<b>P</b>
<b>D.3</b>	<b>Electronic pulse generator</b>		<b>N/A</b>
<b>E</b>	<b>TEST CONDITIONS FOR EQUIPMENT CONTAINING AUDIO AMPLIFIERS</b>		<b>N/A</b>
<b>E.1</b>	<b>Electrical energy source classification for audio signals</b>		<b>N/A</b>
	Maximum non-clipped output power (W).....:		—
	Rated load impedance ( $\Omega$ ) .....		—
	Open-circuit output voltage (V).....:		—
	Instructional safeguard .....	See Clause F.5	—
<b>E.2</b>	<b>Audio amplifier normal operating conditions</b>		<b>N/A</b>
	Audio signal source type.....:		—
	Audio output power (W) .....		—
	Audio output voltage (V).....:		—
	Rated load impedance ( $\Omega$ ) .....		—
	Requirements for temperature measurement	(See Table B.1.5)	N/A
E.3	Audio amplifier abnormal operating conditions	(See Table B.3, B.4)	N/A
<b>F</b>	<b>EQUIPMENT MARKINGS, INSTRUCTIONS, AND INSTRUCTIONAL SAFEGUARDS</b>		<b>P</b>
<b>F.1</b>	<b>General</b>		<b>P</b>
	Language .....		—
<b>F.2</b>	<b>Letter symbols and graphical symbols</b>		<b>P</b>
F.2.1	Letter symbols according to IEC60027-1	Letter symbols for quantities and units are complied with IEC 60027-1.	P
F.2.2	Graphic symbols according to IEC, ISO or manufacturer specific	Graphical symbols are complied with IEC 60417, ISO 3864-2, ISO 7000 or ISO 7010.	P
<b>F.3</b>	<b>Equipment markings</b>		<b>P</b>



IEC 62368-1			
Clause	Requirement + Test	Result - Remark	Verdict
F.3.1	Equipment marking locations	The required marking is located on the enclosure of the equipment and is easily visible.	P
F.3.2	Equipment identification markings	See copy of marking plate.	P
F.3.2.1	Manufacturer identification .....	See copy of marking plate	P
F.3.2.2	Model identification .....	See copy of marking plate.	P
F.3.3	Equipment rating markings	See the following details.	P
F.3.3.1	Equipment with direct connection to mains	The equipment is direct connected to AC mains, see F.3.3.3 to F.3.3.6.	P
F.3.3.2	Equipment without direct connection to mains		N/A
F.3.3.3	Nature of the supply voltage .....	See copy of marking plate	P
F.3.3.4	Rated voltage .....	See copy of marking plate	P
F.3.3.5	Rated frequency .....	See copy of marking plate	P
F.3.3.6	Rated current or rated power.....	See copy of marking plate	P
F.3.3.7	Equipment with multiple supply connections	Only one mains supply connection provided.	N/A
F.3.4	Voltage setting device	No voltage setting device.	N/A
F.3.5	Terminals and operating devices	See below.	P
F.3.5.1	Mains appliance outlet and socket-outlet markings .....	No outlet used.	N/A
F.3.5.2	Switch position identification marking .....		N/A
F.3.5.3	Replacement fuse identification and rating markings .....	Current fuse F1 used, marking provided on PCB: F1: T3.15A/250Vac However, the fuse is not intended to be replaceable.	P
	Instructional safeguards for neutral fuse .....		N/A
F.3.5.4	Replacement battery identification marking.....		N/A
F.3.5.5	Neutral conductor terminal		N/A
F.3.5.6	Terminal marking location		P
F.3.6	Equipment markings related to equipment classification		P
F.3.6.1	Class I equipment	Class II	N/A
F.3.6.1.1	Protective earthing conductor terminal .....		N/A

IEC 62368-1			
Clause	Requirement + Test	Result - Remark	Verdict
F.3.6.1.2	Protective bonding conductor terminals .....		N/A
F.3.6.2	Equipment class marking .....	Class II equipment without functional earth. Symbol  used.	P
F.3.6.3	Functional earthing terminal marking .....		N/A
F.3.7	Equipment IP rating marking .....	IP20	N/A
F.3.8	External power supply output marking.....	See copy of marking plate.	P
F.3.9	Durability, legibility and permanence of marking	Marking is considered to be legible and easily discernible. See also the following details.	P
F.3.10	Test for permanence of markings	The label was subjected to the permanence of marking test. The label was rubbed with cloth soaked with water for 15 sec. And then again for 15 sec. With the cloth soaked with petroleum spirit. After this test there was no damage to the label. The marking on the label did not fade. There was no curling and lifting of the label edge.	P
<b>F.4</b>	<b>Instructions</b>		P
	a) Information prior to installation and initial use		P
	b) Equipment for use in locations where children not likely to be present		N/A
	c) Instructions for installation and interconnection		N/A
	d) Equipment intended for use only in restricted access area		N/A
	e) Equipment intended to be fastened in place		N/A
	f) Instructions for audio equipment terminals		N/A
	g) Protective earthing used as a safeguard		N/A
	h) Protective conductor current exceeding ES2 limits		N/A
	i) Graphic symbols used on equipment		N/A
	j) Permanently connected equipment not provided with all-pole mains switch		N/A
	k) Replaceable components or modules providing safeguard function		N/A

IEC 62368-1			
Clause	Requirement + Test	Result - Remark	Verdict
	l) Equipment containing insulating liquid		N/A
	m) Installation instructions for outdoor equipment		N/A
<b>F.5</b>	Instructional safeguards		N/A
<b>G</b>	<b>COMPONENTS</b>		P
<b>G.1</b>	<b>Switches</b>		N/A
G.1.1	General		N/A
G.1.2	Ratings, endurance, spacing, maximum load		N/A
G.1.3	Test method and compliance		N/A
<b>G.2</b>	<b>Relays</b>		N/A
G.2.1	Requirements		N/A
G.2.2	Overload test		N/A
G.2.3	Relay controlling connectors supplying power to other equipment		N/A
G.2.4	Test method and compliance		N/A
<b>G.3</b>	<b>Protective devices</b>		P
G.3.1	Thermal cut-offs		N/A
	Thermal cut-outs separately approved according to IEC 60730 with conditions indicated in a) & b)		N/A
	Thermal cut-outs tested as part of the equipment as indicated in c)		N/A
G.3.1.2	Test method and compliance		N/A
G.3.2	Thermal links		N/A
G.3.2.1	a) Thermal links tested separately according to IEC 60691 with specifics		N/A
	b) Thermal links tested as part of the equipment		N/A
G.3.2.2	Test method and compliance		N/A
G.3.3	PTC thermistors		N/A
G.3.4	Overcurrent protection devices	Fuse complied with IEC 60127	P
G.3.5	Safeguards components not mentioned in G.3.1 to G.3.4		N/A
G.3.5.1	Non-resettable devices suitably rated and marking provided		N/A
G.3.5.2	Single faults conditions.....:	(See appended table B.4)	N/A
<b>G.4</b>	<b>Connectors</b>		P

IEC 62368-1			
Clause	Requirement + Test	Result - Remark	Verdict
G.4.1	Spacings		P
G.4.2	Mains connector configuration .....		N/A
G.4.3	Plug is shaped that insertion into mains socket-outlets or appliance coupler is unlikely		P
<b>G.5</b>	<b>Wound components</b>		P
G.5.1	Wire insulation in wound components	Approved triple insulation wires (TIW) used for secondary winding of T1	P
G.5.1.2	Protection against mechanical stress	Construction used separate primary winding and secondary winding where they are crossing.	P
G.5.2	Endurance test		N/A
G.5.2.1	General test requirements		N/A
G.5.2.2	Heat run test		N/A
	Test time (days per cycle) .....		—
	Test temperature (°C) .....		—
G.5.2.3	Wound components supplied from the mains		N/A
G.5.2.4	No insulation breakdown		N/A
G.5.3	Transformers		P
G.5.3.1	Compliance method .....	The transformer meets the requirements given in G.5.3.2 and G.5.3.3.	P
	Position.....	T1	P
	Method of protection.....	See G.5.3.2 and G.5.3.3.	P
G.5.3.2	Insulation	Primary windings and secondary windings are separated by Reinforced insulation (The core is considered as primary part as it is not isolated from Primary)	P
	Protection from displacement of windings .....	Approved triple-insulated winding wire used in T1 for secondary winding.	—
G.5.3.3	Transformer overload tests	(See appended table B.3, B.4)	P
G.5.3.3.1	Test conditions	Tested in the complete equipment as an SMPS.	P
G.5.3.3.2	Winding temperatures		P

IEC 62368-1			
Clause	Requirement + Test	Result - Remark	Verdict
G.5.3.3.3	Winding temperatures - alternative test method	Alternative test method was not considered.	N/A
G.5.3.4	Transformers using FIW		N/A
G.5.3.4.1	General		N/A
	FIW wire nominal diameter .....		—
G.5.3.4.2	Transformers with basic insulation only		N/A
G.5.3.4.3	Transformers with double insulation or reinforced insulation .....		N/A
G.5.3.4.4	Transformers with FIW wound on metal or ferrite core		N/A
G.5.3.4.5	Thermal cycling test and compliance		N/A
G.5.3.4.6	Partial discharge test		N/A
G.5.3.4.7	Routine test		N/A
G.5.4	Motors		N/A
G.5.4.1	General requirements		N/A
G.5.4.2	Motor overload test conditions		N/A
G.5.4.3	Running overload test		N/A
G.5.4.4.2	Locked-rotor overload test		N/A
	Test duration (days) .....		—
G.5.4.5	Running overload test for DC motors		N/A
G.5.4.5.2	Tested in the unit		N/A
G.5.4.5.3	Alternative method		N/A
G.5.4.6	Locked-rotor overload test for DC motors		N/A
G.5.4.6.2	Tested in the unit		N/A
	Maximum Temperature .....		N/A
G.5.4.6.3	Alternative method		N/A
G.5.4.7	Motors with capacitors		N/A
G.5.4.8	Three-phase motors		N/A
G.5.4.9	Series motors		N/A
	Operating voltage .....		—
<b>G.6</b>	<b>Wire Insulation</b>		<b>P</b>

IEC 62368-1			
Clause	Requirement + Test	Result - Remark	Verdict
G.6.1	General	Triple insulated winding in T1 secondary windings used as reinforced safeguard in the isolating transformer that has separately complied with Annex J.	P
G.6.2	Enamelled winding wire insulation	Insulation does not rely on solvent-based enamel.	P
<b>G.7</b>	<b>Mains supply cords</b>		N/A
G.7.1	General requirements		N/A
	Type.....:		—
G.7.2	Cross sectional area (mm <sup>2</sup> or AWG).....:		N/A
G.7.3	Cord anchorages and strain relief for non-detachable power supply cords		N/A
G.7.3.2	Cord strain relief		N/A
G.7.3.2.1	Requirements		N/A
	Strain relief test force (N).....:		N/A
G.7.3.2.2	Strain relief mechanism failure		N/A
G.7.3.2.3	Cord sheath or jacket position, distance (mm) .....		N/A
G.7.3.2.4	Strain relief and cord anchorage material		N/A
G.7.4	Cord Entry		N/A
G.7.5	Non-detachable cord bend protection		N/A
G.7.5.1	Requirements		N/A
G.7.5.2	Test method and compliance		N/A
	Overall diameter or minor overall dimension, <i>D</i> (mm).....:		—
	Radius of curvature after test (mm).....:		—
G.7.6	Supply wiring space		N/A
G.7.6.1	General requirements		N/A
G.7.6.2	Stranded wire		N/A
G.7.6.2.1	Requirements		N/A
G.7.6.2.2	Test with 8 mm strand		N/A
<b>G.8</b>	<b>Varistors</b>		N/A
G.8.1	General requirements		N/A
G.8.2	Safeguards against fire		N/A

IEC 62368-1			
Clause	Requirement + Test	Result - Remark	Verdict
G.8.2.1	General		N/A
G.8.2.2	Varistor overload test		N/A
G.8.2.3	Temporary overvoltage test		N/A
<b>G.9</b>	<b>Integrated circuit (IC) current limiters</b>		N/A
G.9.1	Requirements		N/A
	IC limiter output current (max. 5A) .....		—
	Manufacturers' defined drift .....		—
G.9.2	Test Program		N/A
G.9.3	Compliance		N/A
<b>G.10</b>	<b>Resistors</b>		N/A
G.10.1	General	No such resistor as safeguard used	N/A
G.10.2	Conditioning		N/A
G.10.3	Resistor test		N/A
G.10.4	Voltage surge test		N/A
G.10.5	Impulse test		N/A
G.10.6	Overload test		N/A
<b>G.11</b>	<b>Capacitors and RC units</b>		P
G.11.1	General requirements	(See appended table 4.1.2)	P
G.11.2	Conditioning of capacitors and RC units	(See appended table 4.1.2)	P
G.11.3	Rules for selecting capacitors		P
<b>G.12</b>	<b>Optocouplers</b>		P
	Optocouplers comply with IEC 60747-5-5 with specifics	(See appended table 4.1.2)	P
	Type test voltage $V_{ini,a}$ .....		—
	Routine test voltage, $V_{ini,b}$ .....		—
<b>G.13</b>	<b>Printed boards</b>		P
G.13.1	General requirements	Approved Printed board used	P
G.13.2	Uncoated printed boards	The insulation between conductors on the outer surfaces of an uncoated printed board complied with the minimum clearance and creepage requirements	P

IEC 62368-1			
Clause	Requirement + Test	Result - Remark	Verdict
G.13.3	Coated printed boards	No coated printed board or multilayer board applied for within the equipment.	N/A
G.13.4	Insulation between conductors on the same inner surface		N/A
G.13.5	Insulation between conductors on different surfaces		N/A
	Distance through insulation .....		N/A
	Number of insulation layers (pcs) .....		—
G.13.6	Tests on coated printed boards		N/A
G.13.6.1	Sample preparation and preliminary inspection		N/A
G.13.6.2	Test method and compliance		N/A
<b>G.14</b>	<b>Coating on components terminals</b>		N/A
G.14.1	Requirements .....	(See Clause G.13)	N/A
<b>G.15</b>	<b>Pressurized liquid filled components</b>		N/A
G.15.1	Requirements		N/A
G.15.2	Test methods and compliance		N/A
G.15.2.1	Hydrostatic pressure test		N/A
G.15.2.2	Creep resistance test		N/A
G.15.2.3	Tubing and fittings compatibility test		N/A
G.15.2.4	Vibration test		N/A
G.15.2.5	Thermal cycling test		N/A
G.15.2.6	Force test		N/A
G.15.3	Compliance		N/A
<b>G.16</b>	<b>IC including capacitor discharge function (ICX)</b>		N/A
G.16.1	Condition for fault tested is not required		N/A
	ICX with associated circuitry tested in equipment		N/A
	ICX tested separately		N/A
G.16.2	Tests		N/A
	Smallest capacitance and smallest resistance specified by ICX manufacturer for impulse test .....		—
	Mains voltage that impulses to be superimposed on .....		—
	Largest capacitance and smallest resistance for ICX tested by itself for 10000 cycles test .....		—
G.16.3	Capacitor discharge test .....		N/A



IEC 62368-1			
Clause	Requirement + Test	Result - Remark	Verdict
<b>H</b>	<b>CRITERIA FOR TELEPHONE RINGING SIGNALS</b>		N/A
<b>H.1</b>	<b>General</b>		N/A
<b>H.2</b>	<b>Method A</b>		N/A
<b>H.3</b>	<b>Method B</b>		N/A
H.3.1	Ringling signal		N/A
H.3.1.1	Frequency (Hz) .....		—
H.3.1.2	Voltage (V) .....		—
H.3.1.3	Cadence; time (s) and voltage (V) .....		—
H.3.1.4	Single fault current (mA): .....		—
H.3.2	Tripping device and monitoring voltage		N/A
H.3.2.1	Conditions for use of a tripping device or a monitoring voltage		N/A
H.3.2.2	Tripping device		N/A
H.3.2.3	Monitoring voltage (V).....		N/A
<b>J</b>	<b>INSULATED WINDING WIRES FOR USE WITHOUT INTERLEAVED INSULATION</b>		P
<b>J.1</b>	<b>General</b>		P
	Winding wire insulation.....		—
	Solid round winding wire, diameter (mm) .....		N/A
	Solid square and rectangular (flatwise bending) winding wire, cross-sectional area (mm <sup>2</sup> ).....		N/A
<b>J.2/J.3</b>	Tests and Manufacturing		N/A
<b>K</b>	<b>SAFETY INTERLOCKS</b>		N/A
<b>K.1</b>	<b>General requirements</b>		N/A
	Instructional safeguard .....		N/A
<b>K.2</b>	<b>Components of safety interlock safeguard mechanism</b>		N/A
<b>K.3</b>	<b>Inadvertent change of operating mode</b>		N/A
<b>K.4</b>	<b>Interlock safeguard override</b>		N/A
<b>K.5</b>	<b>Fail-safe</b>		N/A
K.5.1	Under single fault condition		N/A
<b>K.6</b>	<b>Mechanically operated safety interlocks</b>		N/A
K.6.1	Endurance requirement		N/A
K.6.2	Test method and compliance.....		N/A
<b>K.7</b>	<b>Interlock circuit isolation</b>		N/A

IEC 62368-1			
Clause	Requirement + Test	Result - Remark	Verdict
K.7.1	Separation distance for contact gaps & interlock circuit elements		N/A
	In circuit connected to mains, separation distance for contact gaps (mm).....:		N/A
	In circuit isolated from mains, separation distance for contact gaps (mm).....:		N/A
	Electric strength test before and after the test of K.7.2.....:	(See appended table 5.4.9)	N/A
K.7.2	Overload test, Current (A) .....		N/A
K.7.3	Endurance test		N/A
K.7.4	Electric strength test		N/A
<b>L</b>	<b>DISCONNECT DEVICES</b>		<b>P</b>
<b>L.1</b>	<b>General requirements</b>	Plug portion used as disconnect device	<b>P</b>
<b>L.2</b>	<b>Permanently connected equipment</b>		<b>N/A</b>
<b>L.3</b>	<b>Parts that remain energized</b>	When AC plug is disconnected no hazardous voltage in the equipment.	<b>P</b>
<b>L.4</b>	<b>Single-phase equipment</b>	The mains plug disconnects both poles simultaneously.	<b>P</b>
<b>L.5</b>	<b>Three-phase equipment</b>		<b>N/A</b>
<b>L.6</b>	<b>Switches as disconnect devices</b>		<b>N/A</b>
<b>L.7</b>	<b>Plugs as disconnect devices</b>	See above	<b>P</b>
<b>L.8</b>	<b>Multiple power sources</b>	Only one a.c. mains connection.	<b>N/A</b>
	Instructional safeguard .....		<b>N/A</b>
<b>M</b>	<b>EQUIPMENT CONTAINING BATTERIES AND THEIR PROTECTION CIRCUITS</b>		<b>N/A</b>
<b>M.1</b>	<b>General requirements</b>		<b>N/A</b>
<b>M.2</b>	<b>Safety of batteries and their cells</b>		<b>N/A</b>
M.2.1	Batteries and their cells comply with relevant IEC standards .....		<b>N/A</b>
<b>M.3</b>	<b>Protection circuits for batteries provided within the equipment</b>		<b>N/A</b>
M.3.1	Requirements		<b>N/A</b>
M.3.2	Test method		<b>N/A</b>
	Overcharging of a rechargeable battery		<b>N/A</b>
	Excessive discharging		<b>N/A</b>

IEC 62368-1			
Clause	Requirement + Test	Result - Remark	Verdict
	Unintentional charging of a non-rechargeable battery		N/A
	Reverse charging of a rechargeable battery		N/A
M.3.3	Compliance	(See appended table M.3)	N/A
<b>M.4</b>	<b>Additional safeguards for equipment containing a portable secondary lithium battery</b>		N/A
M.4.1	General		N/A
M.4.2	Charging safeguards		N/A
M.4.2.1	Requirements		N/A
M.4.2.2	Compliance.....:	(See appended table M.4.2)	N/A
M.4.3	Fire enclosure .....		N/A
M.4.4	Drop test of equipment containing a secondary lithium battery		N/A
M.4.4.2	Preparation and procedure for the drop test		N/A
M.4.4.3	Drop, Voltage on reference and dropped batteries (V); voltage difference during 24 h period (%): .....		N/A
M.4.4.4	Check of the charge/discharge function		N/A
M.4.4.5	Charge / discharge cycle test		N/A
M.4.4.6	Compliance		N/A
<b>M.5</b>	<b>Risk of burn due to short-circuit during carrying</b>		N/A
M.5.1	Requirement		N/A
M.5.2	Test method and compliance		N/A
<b>M.6</b>	<b>Safeguards against short-circuits</b>		N/A
M.6.1	External and internal faults		N/A
M.6.2	Compliance		N/A
<b>M.7</b>	<b>Risk of explosion from lead acid and NiCd batteries</b>		N/A
M.7.1	Ventilation preventing explosive gas concentration		N/A
	Calculated hydrogen generation rate .....		N/A
M.7.2	Test method and compliance		N/A
	Minimum air flow rate, Q (m <sup>3</sup> /h) .....		N/A
M.7.3	Ventilation tests		N/A
M.7.3.1	General		N/A
M.7.3.2	Ventilation test – alternative 1		N/A
	Hydrogen gas concentration (%) .....		N/A

IEC 62368-1			
Clause	Requirement + Test	Result - Remark	Verdict
M.7.3.3	Ventilation test – alternative 2		N/A
	Obtained hydrogen generation rate.....:		N/A
M.7.3.4	Ventilation test – alternative 3		N/A
	Hydrogen gas concentration (%).....:		N/A
M.7.4	Marking.....:		N/A
<b>M.8</b>	<b>Protection against internal ignition from external spark sources of batteries with aqueous electrolyte</b>		N/A
M.8.1	General		N/A
M.8.2	Test method		N/A
M.8.2.1	General		N/A
M.8.2.2	Estimation of hypothetical volume $V_2$ (m <sup>3</sup> /s).....:		—
M.8.2.3	Correction factors.....:		—
M.8.2.4	Calculation of distance $d$ (mm).....:		—
<b>M.9</b>	<b>Preventing electrolyte spillage</b>		N/A
M.9.1	Protection from electrolyte spillage		N/A
M.9.2	Tray for preventing electrolyte spillage		N/A
<b>M.10</b>	<b>Instructions to prevent reasonably foreseeable misuse</b>		N/A
	Instructional safeguard.....:		N/A
<b>N</b>	<b>ELECTROCHEMICAL POTENTIALS</b>		N/A
	Material(s) used.....:		—
<b>O</b>	<b>MEASUREMENT OF CREEPAGE DISTANCES AND CLEARANCES</b>		P
	Value of $X$ (mm).....:		—
<b>P</b>	<b>SAFEGUARDS AGAINST CONDUCTIVE OBJECTS</b>		N/A
<b>P.1</b>	<b>General</b>		N/A
<b>P.2</b>	<b>Safeguards against entry or consequences of entry of a foreign object</b>		N/A
P.2.1	General		N/A
P.2.2	Safeguards against entry of a foreign object		N/A
	Location and Dimensions (mm).....:		—
P.2.3	Safeguards against the consequences of entry of a foreign object		N/A
P.2.3.1	Safeguard requirements		N/A
	The ES3 and PS3 keep-out volume in Figure P.3 not applicable to transportable equipment		N/A

IEC 62368-1			
Clause	Requirement + Test	Result - Remark	Verdict
	Transportable equipment with metalized plastic parts .....		N/A
P.2.3.2	Consequence of entry test .....		N/A
<b>P.3</b>	<b>Safeguards against spillage of internal liquids</b>		N/A
P.3.1	General		N/A
P.3.2	Determination of spillage consequences		N/A
P.3.3	Spillage safeguards		N/A
P.3.4	Compliance		N/A
<b>P.4</b>	<b>Metallized coatings and adhesives securing parts</b>		N/A
P.4.1	General		N/A
P.4.2	Tests		N/A
	Conditioning, T <sub>c</sub> (°C).....		—
	Duration (weeks).....		—
<b>Q</b>	<b>CIRCUITS INTENDED FOR INTERCONNECTION WITH BUILDING WIRING</b>		P
<b>Q.1</b>	<b>Limited power sources</b>	See appended table Annex Q.1	P
Q.1.1	Requirements		P
	a) Inherently limited output		N/A
	b) Impedance limited output		N/A
	c) Regulating network limited output	A regulating network limits the output in compliance with table Q.1 both under normal operating conditions and after any single fault.	P
	d) Overcurrent protective device limited output		N/A
	e) IC current limiter complying with G.9		N/A
Q.1.2	Test method and compliance.....	See appended table Annex Q.1	P
	Current rating of overcurrent protective device (A) .....		N/A
<b>Q.2</b>	<b>Test for external circuits – paired conductor cable</b>		N/A
	Maximum output current (A) .....		N/A
	Current limiting method.....		—
<b>R</b>	<b>LIMITED SHORT CIRCUIT TEST</b>		N/A
<b>R.1</b>	<b>General</b>		N/A

IEC 62368-1			
Clause	Requirement + Test	Result - Remark	Verdict
<b>R.2</b>	<b>Test setup</b>		N/A
	Overcurrent protective device for test.....:		—
<b>R.3</b>	<b>Test method</b>		N/A
	Cord/cable used for test.....:		—
<b>R.4</b>	<b>Compliance</b>		N/A
<b>S</b>	<b>TESTS FOR RESISTANCE TO HEAT AND FIRE</b>		P
<b>S.1</b>	<b>Flammability test for fire enclosures and fire barrier materials of equipment where the steady state power does not exceed 4 000 W</b>		P
	Samples, material.....:		—
	Wall thickness (mm).....:		—
	Conditioning (°C).....:		—
	Test flame according to IEC 60695-11-5 with conditions as set out		N/A
	- Material not consumed completely		N/A
	- Material extinguishes within 30s		N/A
	- No burning of layer or wrapping tissue		N/A
<b>S.2</b>	<b>Flammability test for fire enclosure and fire barrier integrity</b>		N/A
	Samples, material.....:		—
	Wall thickness (mm).....:		—
	Conditioning (°C).....:		—
<b>S.3</b>	<b>Flammability test for the bottom of a fire enclosure</b>		N/A
S.3.1	Mounting of samples		N/A
S.3.2	Test method and compliance		N/A
	Mounting of samples.....:		—
	Wall thickness (mm).....:		—
<b>S.4</b>	<b>Flammability classification of materials</b>	See Table 4.1.2 only.	P
<b>S.5</b>	<b>Flammability test for fire enclosure materials of equipment with a steady state power exceeding 4 000 W</b>		N/A
	Samples, material.....:		—
	Wall thickness (mm).....:		—
	Conditioning (°C).....:		—
<b>T</b>	<b>MECHANICAL STRENGTH TESTS</b>		P
<b>T.1</b>	<b>General</b>		P

IEC 62368-1			
Clause	Requirement + Test	Result - Remark	Verdict
<b>T.2</b>	<b>Steady force test, 10 N</b> .....	(See appended table T.2)	P
<b>T.3</b>	<b>Steady force test, 30 N</b> .....		N/A
<b>T.4</b>	<b>Steady force test, 100 N</b> .....	(See appended table T.4)	P
<b>T.5</b>	<b>Steady force test, 250 N</b> .....		N/A
<b>T.6</b>	<b>Enclosure impact test</b>		N/A
	Fall test		N/A
	Swing test		N/A
<b>T.7</b>	<b>Drop test</b> .....	(See appended table T.7)	P
<b>T.8</b>	<b>Stress relief test</b> .....	(See appended table T.8)	P
<b>T.9</b>	<b>Glass Impact Test</b> .....	(See appended table T.9)	N/A
<b>T.10</b>	<b>Glass fragmentation test</b>		N/A
	Number of particles counted.....		N/A
<b>T.11</b>	<b>Test for telescoping or rod antennas</b>		N/A
	Torque value (Nm) .....		N/A
<b>U</b>	<b>MECHANICAL STRENGTH OF CATHODE RAY TUBES (CRT) AND PROTECTION AGAINST THE EFFECTS OF IMPLOSION</b>		N/A
<b>U.1</b>	<b>General</b>		N/A
	Instructional safeguard :		N/A
<b>U.2</b>	<b>Test method and compliance for non-intrinsically protected CRTs</b>		N/A
<b>U.3</b>	<b>Protective screen</b>		N/A
<b>V</b>	<b>DETERMINATION OF ACCESSIBLE PARTS</b>		P
<b>V.1</b>	<b>Accessible parts of equipment</b>		P
V.1.1	General		P
V.1.2	Surfaces and openings tested with jointed test probes		P
V.1.3	Openings tested with straight unjointed test probes		P
V.1.4	Plugs, jacks, connectors tested with blunt probe		N/A
V.1.5	Slot openings tested with wedge probe		N/A
V.1.6	Terminals tested with rigid test wire		N/A
<b>V.2</b>	<b>Accessible part criterion</b>		P
<b>X</b>	<b>ALTERNATIVE METHOD FOR DETERMINING CLEARANCES FOR INSULATION IN CIRCUITS CONNECTED TO AN AC MAINS NOT EXCEEDING 420 V PEAK (300 V RMS)</b>		N/A
	Clearance .....	(See appended table X)	N/A

IEC 62368-1			
Clause	Requirement + Test	Result - Remark	Verdict
<b>Y</b>	<b>CONSTRUCTION REQUIREMENTS FOR OUTDOOR ENCLOSURES</b>		N/A
<b>Y.1</b>	<b>General</b>		N/A
<b>Y.2</b>	<b>Resistance to UV radiation</b>		N/A
<b>Y.3</b>	<b>Resistance to corrosion</b>		N/A
<b>Y.3</b>	<b>Resistance to corrosion</b>		N/A
Y.3.1	Metallic parts of outdoor enclosures are resistant to effects of water-borne contaminants by .....		N/A
Y.3.2	Test apparatus		N/A
Y.3.3	Water – saturated sulphur dioxide atmosphere		N/A
Y.3.4	Test procedure .....		N/A
Y.3.5	Compliance		N/A
<b>Y.4</b>	<b>Gaskets</b>		N/A
Y.4.1	General		N/A
Y.4.2	Gasket tests		N/A
Y.4.3	Tensile strength and elongation tests		N/A
	Alternative test methods .....		N/A
Y.4.4	Compression test		N/A
Y.4.5	Oil resistance		N/A
Y.4.6	Securing means	(See Annex P.4)	N/A
<b>Y.5</b>	<b>Protection of equipment within an outdoor enclosure</b>		N/A
Y.5.1	General		N/A
Y.5.2	Protection from moisture		N/A
	Relevant tests of IEC 60529 or Y.5.3 .....		N/A
Y.5.3	Water spray test		N/A
Y.5.4	Protection from plants and vermin		N/A
Y.5.5	Protection from excessive dust		N/A
Y.5.5.1	General		N/A
Y.5.5.2	IP5X equipment		N/A
Y.5.5.3	IP6X equipment		N/A
<b>Y.6</b>	<b>Mechanical strength of enclosures</b>		N/A
Y.6.1	General		N/A
Y.6.2	Impact test.....	(See Table T.6)	N/A



IEC 62368-1			
Clause	Requirement + Test	Result - Remark	Verdict

5.2		TABLE: Classification of electrical energy sources					P
Supply Voltage	Location (e.g. circuit designation)	Test conditions	Parameters				ES Class
			U (V)	I (mA)	Type <sup>1)</sup>	Additional Info <sup>2)</sup>	
Model: MC-682N							
264Vac (Loading: 20Vdc, 3.4A)	Output + to -	Normal	19.58Vdc	--	SS	DC	ES1
		Abnormal (Overload)	19.58Vdc	--	SS	DC	ES1
		Single fault (see table B.3, B.4)	0	--	SS	DC	ES1
264Vac (Loading: 15Vdc, 3A)	Output + to -	Normal	15.00Vdc	--	SS	DC	ES1
		Abnormal (Overload)	15.00Vdc	--	SS	DC	ES1
		Single fault (see table B.3, B.4)	0	--	SS	DC	ES1
264Vac (Loading: 11Vdc, 6.2A)	Output + to -	Normal	10.76Vdc	--	SS	DC	ES1
		Abnormal (Overload)	10.76Vdc	--	SS	DC	ES1
		Single fault (see table B.3, B.4)	0	--	SS	DC	ES1
264Vac (Loading: 9Vdc, 3A)	Output + to -	Normal	9.00Vdc	--	SS	DC	ES1
		Abnormal (Overload)	9.00Vdc	--	SS	DC	ES1
		Single fault (see table B.3, B.4)	0	--	SS	DC	ES1
264Vac (Loading: 5Vdc, 3A)	Output + to -	Normal	5.03Vdc	--	SS	DC	ES1
		Abnormal (Overload)	5.03Vdc	--	SS	DC	ES1
		Single fault (see table B.3, B.4)	0	--	SS	DC	ES1
264Va.c (Loading: 20Vdc, 3.4A) (CY1=CY2=	Enclosure to earth	Normal	--	0.024 mApk	SS	60	ES1
		Abnormal (Overload)	--	0.024 mApk	SS	60	ES1

IEC 62368-1							
Clause	Requirement + Test			Result - Remark			Verdict
150pF)		Single fault (see table B.3, B.4)	--	0.024 mApk	SS	60	ES1
264Va.c (Loading: 20Vdc, 3.4A) (CY1=CY2= 150pF)	Output +/- to earth	Normal	--	0.080 mApk	SS	60	ES1
		Abnormal (Overload)	--	0.080 mApk	SS	60	ES1
		Single fault (see table B.3, B.4)	--	0.080 mApk	SS	60	ES1
Supplementary information:							
1) Type: Steady state (SS), Capacitance (CP), Single pulse (SP), Repetitive pulses (RP), etc.							
2) Additional Info: Frequency, Pulse duration, Pulse off time, Capacitance value, etc.							

5.4.1.8	TABLE: Working voltage measurement				P
Location	RMS voltage (V)	Peak voltage (V)	Frequency (Hz)	Comments	
Model: MC-682N (Loading: 11Vdc 6.2A)					
T1 Pin 1-5	196	496	--	--	
T1 Pin 3-5	188	368	--	--	
T1 Pin 7-5	260	512	--	--	
T1 Pin 8-5	220	352	--	--	
T1 Pin 1-6	204	<b>576</b>	98.63k	<b>The Max. V<sub>peak</sub> 98.63kHz</b>	
T1 Pin 3-6	188	424	--	--	
T1 Pin 7-6	<b>276</b>	544	98.63k	<b>The Max. Vr.m.s 98.63kHz</b>	
T1 Pin 8-6	220	368	--	--	
CY1 Pin Pri-Sec	240	360	--	--	
CY2 Pin Pri-Sec	180	352	--	--	
U2 pin 1-3	186	368	--	--	
U2 pin 1-4	186	364	--	--	
U2 pin 2-3	186	368	--	--	
U2 pin 2-4	186	364	--	--	
Model: MC-682N (Loading: 20Vdc 3.4A)					
T1 Pin 1-5	204	512	--	--	

IEC 62368-1				
Clause	Requirement + Test		Result - Remark	Verdict
T1 Pin 3-5	192	368	--	--
T1 Pin 7-5	264	552	--	--
T1 Pin 8-5	214	336	--	--
T1 Pin 1-6	218	576	--	--
T1 Pin 3-6	194	432	--	--
T1 Pin 7-6	<b>284</b>	<b>592</b>	92.36k	<b>The Max. V<sub>peak</sub> and Max. Vr.m.s, 92.36kHz</b>
T1 Pin 8-6	214	376	--	--
CY1 Pin Pri-Sec	240	360	--	--
CY2 Pin Pri-Sec	180	352	--	--
U2 pin 1-3	190	368	--	--
U2 pin 1-4	190	372	--	--
U2 pin 2-3	190	368	--	--
U2 pin 2-4	190	372	--	--
Supplementary information:				
Test voltage: 240V				
Frequency: 60Hz				

5.4.1.10.2 TABLE: Vicat softening temperature of thermoplastics				N/A
Method..... :			ISO 306 / B50	—
Object/ Part No./Material	Manufacturer/trademark	Thickness (mm)	T softening (°C)	
--	--	--	--	
--	--	--	--	
Supplementary information:				
--				

5.4.1.10.3 TABLE: Ball pressure test of thermoplastics					P
Allowed impression diameter (mm)..... :				≤ 2 mm	—
Object/Part No./Material	Manufacturer/trademark	Thickness (mm)	Test temperature (°C)	Impression diameter (mm)	

IEC 62368-1				
Clause	Requirement + Test	Result - Remark		Verdict
Plug holder	LOTTE CHEMICAL CORPORATION / HN-1064(+)	1.5mm*2	125	0.9
Plug holder	SABIC INNOVATIVE PLASTICS US L L C / 945 (GG)	1.5mm*2	125	0.9
Plug holder	SABIC JAPAN L L C / 945 (GG)	1.5mm*2	125	1.0
Plug holder	COVESTRO DEUTSCHLAND AG [PC RESINS] / FR6005	1.5mm*2	125	1.0
Plug holder	DONGGUAN HUAZHE METALS & PLASTICS LTD / HZ-88	1.5mm*2	125	1.0
Supplementary information:				
The bobbin material of transformer (T1) is phenolic, no test is needed.				

5.4.2, 5.4.3 TABLE: Minimum Clearances/Creepage distance								P
Clearance (cl) and creepage distance (cr) at/of/between:	U <sub>p</sub> (V)	U <sub>rms</sub> (V)	Freq <sup>1)</sup> (Hz)	Required cl (mm)	cl (mm)	E.S. <sup>2)</sup> (V)	Required cr (mm)	cr (mm)
Basic/supplementary:								
L-N trace before fuse F1 (BI)	420	250	60	2.3	11.20	--	2.5	11.20
Different polarity of fuse F1 (BI)	420	250	60	2.3	3.1	--	2.5	3.1
Live line before fuse to R3 (BI)	420	250	60	2.3	3.4	--	2.5	3.4
Reinforce:								
Primary circuit to secondary circuit (PCB under CY1) (RI)	420	250	60	4.5	6.4	--	5.0	6.4
Primary circuit to secondary circuit (PCB under CY2) (RI)	420	250	60	4.5	6.4	--	5.0	6.4
Metal above the insulation sheet to Secondary components (RI)	420	250	60	4.5	5.2	--	5.0	5.2
Primary circuit to enclosure (RI)	592	284	98.63k	4.5	8.8	--	5.8	8.8
PCB trace under transformer T1 (RI)	592	284	98.63k	4.5	6.9	--	5.8	6.9

IEC 62368-1								
Clause	Requirement + Test				Result - Remark			Verdict
Primary winding to secondary winding (RI)	592	284	98.63k	4.5	7.1	--	5.8	7.1
Core to secondary winding (RI)	592	284	98.63k	4.5	9.2	--	5.8	9.2
Supplementary information:								
<p>1. The transformer core considered as primary circuit.</p> <p>2. At least 2 layer of insulation tape between primary (enamelled copper wire) and secondary windings (triple insulation wire), 2 layers on outer winding. There are no contact point of primary winding and secondary winding. 2 layers insulation tape wrapped on transformer body.</p> <p>3. Unless otherwise specified, the worst conditions of Cl. &amp; Cr. in above mentioned locations have been considered and listed.</p> <p>1) Only for frequency above 30 kHz</p> <p>2) Complete Electric Strength voltage (E. S. (V) when 5.4.2.4 applied)</p> <p>4. The equipment was evaluated for a maximum operating altitude of 5000 m. therefore the requirements of IEC 62368-1 for clearances were considered and the required clearance was multiplied with an altitude correction factor of 1.48.</p>								

5.4.4.2	TABLE: Minimum distance through insulation				P
Distance through insulation (DTI) at/of	Peak voltage (V)	Insulation	Required DTI (mm)	Measured DTI (mm)	
Enclosure	592	See appended table 4.1.2	0.4	1)	
Bobbin of T1	592	See appended table 4.1.2	0.4	1)	
Insulation sheet	592	See appended table 4.1.2	0.4	1)	
Supplementary information:					
1): See appended table 4.1.2.					

5.4.4.9	TABLE: Solid insulation at frequencies >30 kHz					P
Insulation material	$E_P$	Frequency (kHz)	$K_R$	Thickness $d$ (mm)	Insulation	$V_{PW}$ (Vpk)
Enclosure	160	98.63	0.35	1.5	Reinforced	592
Bobbin	17	98.63	0.71	0.71	Reinforced	592
Bobbin	--	98.63	0.35	0.71	Reinforced	592
Insulation tape	55	98.63	0.46	Min. 2 layers	Reinforced	592

IEC 62368-1						
Clause	Requirement + Test			Result - Remark		Verdict
Insulation tape (other materials)	--	98.63	0.46	Min. 2 layers	Reinforced	592
Insulation sheet	160	98.63	0.49	0.75	Reinforced	592
Supplementary information:						
Enclosure: Alternative method: Electric strength test voltage = $1.2 \cdot 2 \cdot V_{PW} / K_R = 1.2 \cdot 2 \cdot 592 / 0.35 = 4060V$ Bobbin of T1: Alternative method: Electric strength test voltage = $1.2 \cdot 2 \cdot V_{PW} / K_R = 1.2 \cdot 2 \cdot 592 / 0.71 = 2002V$ Alternative method: Electric strength test voltage = $1.2 \cdot 2 \cdot V_{PW} / K_R = 1.2 \cdot 2 \cdot 592 / 0.35 = 4060V$ Insulation sheet: Alternative method: Electric strength test voltage = $1.2 \cdot 2 \cdot V_{PW} / K_R = 1.2 \cdot 2 \cdot 592 / 0.49 = 2900V$ Insulation tape: Alternative method: Electric strength test voltage = $1.2 \cdot 2 \cdot V_{PW} / K_R = 1.2 \cdot 2 \cdot 592 / 0.46 = 3089V$ Alternative method: Electric strength test voltage = $1.2 \cdot 2 \cdot V_{PW} / K_R = 1.2 \cdot 2 \cdot 592 / 0.46 = 3089V$						

5.4.9	TABLE: Electric strength tests			P
Test voltage applied between:	Voltage shape (Surge, Impulse, AC, DC, etc.)	Test voltage (V)	Breakdown Yes / No	
Basic/supplementary:				
L to N (removed the F1)	DC	2500	No	
Heat shrinkable tube of F1	DC	2500	No	
Reinforced:				
L/N & output terminal	DC	4000	No	
L/N & enclosure gap wrapped with foil	DC	4000	No	
T1 Primary winding to secondary winding	DC	4000	No	
T1 core to secondary winding	DC	4000	No	
One layer insulation tape	DC	4000	No	
Transformer bobbin (Phenolic)	DC	4000	No	
Output to Metal above the insulation sheet	DC	4000	No	
Insulation sheet	DC	4000	No	
Transformer bobbin (other materials)	DC	4060	No	
internal barrier	DC	4000	No	
Supplementary information:				
Core of transformer T1 was considered as primary. Tests were performed on product with each source listed in table 4.1.2.				

IEC 62368-1			
Clause	Requirement + Test	Result - Remark	Verdict

5.5.2.2 TABLE: Stored discharge on capacitors					P
Location	Supply voltage (V)	Operating and fault condition <sup>1)</sup>	Switch position	Measured voltage (V <sub>pk</sub> )	ES Class
Between L and N	264Vac, 60Hz	Normal, output no load	--	0V	ES1
Between L and N	264Vac, 60Hz	Single fault (R3 open circuit)	--	4V	ES1
Supplementary information:					
X-capacitors installed for testing: CX1: 0.1µF					
[X] bleeding resistor rating: R3=R4=R6=R7= 2.0M ohm, total: 2.0M ohm.					
[ ] ICX:					
1) Normal operating condition (e.g., normal operation, or open fuse), SC= short circuit, OC= open circuit					

5.6.6 TABLE: Resistance of protective conductors and terminations					N/A
Location	Test current (A)	Duration (min)	Voltage drop (V)	Resistance (Ω)	
--	--	--	--	--	
Supplementary information:					
--					

5.7.4 TABLE: Unearthed accessible parts						P
Location	Operating and fault conditions	Supply Voltage (V)	Parameters			ES class
			Voltage (V <sub>rms</sub> or V <sub>pk</sub> )	Current (A <sub>rms</sub> or A <sub>pk</sub> )	Freq. (Hz)	
Model: MC-682N						
Output + to - (Loading: 20Vdc, 3.4A)	Normal	264Va.c., 60Hz	19.22Vdc	--	DC	ES1
	Abnormal (Overload)		19.22Vdc	--	DC	ES1
	Single fault (see table B.3, B.4)		0	--	DC	ES1
Output + to - (Loading: 15Vdc, 3A)	Normal	264Va.c., 60Hz	14.72Vdc	--	DC	ES1
	Abnormal (Overload)		14.72Vdc	--	DC	ES1
	Single fault (see table B.3,		0	--	DC	ES1

IEC 62368-1						
Clause	Requirement + Test		Result - Remark			Verdict
	B.4)					
Output + to - (Loading: 11Vdc, 6.2A)	Normal	264Va.c, 60Hz	10.21Vdc	--	DC	ES1
	Abnormal (Overload)		10.21Vdc	--	DC	ES1
	Single fault (see table B.3, B.4)		0	--	DC	ES1
Output + to - (Loading: 9Vdc, 3A)	Normal	264Va.c, 60Hz	8.74Vdc	--	DC	ES1
	Abnormal (Overload)		8.74Vdc	--	DC	ES1
	Single fault (see table B.3, B.4)		0	--	DC	ES1
Output + to - (Loading: 5Vdc, 3A)	Normal	264Va.c, 60Hz	4.85Vdc	--	DC	ES1
	Abnormal (Overload)		4.85Vdc	--	DC	ES1
	Single fault (see table B.3, B.4)		0	--	DC	ES1
Output +/- to earth	Normal	264Va.c, 60Hz	--	0.080mApk	60	ES1
	Abnormal (Overload)		--	0.080mApk	60	ES1
	Single fault (see table B.3, B.4)		--	0.080mApk	60	ES1
Enclosure to earth	Normal	264Va.c, 60Hz	--	0.024mApk	60	ES1
	Abnormal (Overload)		--	0.024mApk	60	ES1
	Single fault (see table B.3, B.4)		--	0.024mApk	60	ES1

Supplementary information:

Abbreviation: SC= short circuit; OC= open circuit

<b>5.7.5</b>	<b>TABLE: Earthed accessible conductive part</b>	N/A
Supply voltage (V) .....		—
Phase(s) .....	<input type="checkbox"/> Single Phase; <input type="checkbox"/> Three Phase: <input type="checkbox"/> Delta <input type="checkbox"/> Wye	



IEC 62368-1			
Clause	Requirement + Test	Result - Remark	Verdict
Power Distribution System .....		[ ] TN [ ] TT [ ] IT	
Location	Fault Condition No in IEC 60990 clause 6.2.2	Touch current (mA)	Comment
--	--	--	--
Supplementary Information:			
--			

5.8	TABLE: Backfeed safeguard in battery backed up supplies					N/A
Location	Supply voltage (V)	Operating and fault condition	Time (s)	Open-circuit voltage (V)	Touch current (A)	ES Class
--	--	--	--	--	--	--
Supplementary information:						
Abbreviation: SC= short circuit, OC= open circuit						

6.2.2	TABLE: Power source circuit classifications					P
Location	Operating and fault condition	Voltage (V)	Current (A)	Max. Power <sup>1)</sup> (W)	Time (S)	PS class
Input: 264Vac, 60Hz; Output (Loading: 5Vdc, 3A)	Normal	4.83	3.15	15.2	5	PS2
	Abnormal operation	--	--	--	--	PS1
	Single Fault (Component SC)	--	--	--	--	PS1
Input: 264Vac, 60Hz; Output (Loading: 9Vdc, 3A)	Normal	8.73	3.15	27.5	5	PS2
	Abnormal operation	--	--	--	--	PS1
	Single Fault (Component SC)	--	--	--	--	PS1
Input: 264Vac, 60Hz; Output (Loading: 11Vdc, 6.2A)	Normal	10.03	6.49	65.1	5	PS2
	Abnormal operation	--	--	--	--	PS1
	Single Fault (Component SC)	--	--	--	--	PS1
Input: 264Vac, 60Hz; Output	Normal	14.70	3.15	46.3	5	PS2
	Abnormal operation	--	--	--	--	PS1

IEC 62368-1						
Clause	Requirement + Test	Result - Remark				Verdict
(Loading: 15Vdc, 3A)	Single Fault (Component SC)	--	--	--	--	PS1
Input: 264Vac, 60Hz; Output (Loading: 20Vdc, 3.4A)	Normal	19.17	3.61	69.2	5	PS2
	Abnormal operation	--	--	--	--	PS1
	Single Fault (Component SC)	--	--	--	--	PS1
Supplementary information:						
Abbreviation: SC= short circuit; OC= open circuit						
1) Measured after 3 s for PS1 and measured after 5 s for PS2 and PS3.						

6.2.3.1	TABLE: Determination of Arcing PIS				P
Location	Open circuit voltage after 3 s (Vpk)	Measured r.m.s current (A)	Calculated value	Arcing PIS? Yes / No	
See below	--	--	--	--	
Supplementary information:					
An Arcing PIS requires a minimum of 50 V (peak) a.c. or d.c. An Arcing PIS is established when the product of the open circuit voltage ( $V_p$ ) and normal operating condition rms current ( $I_{rms}$ ) is greater than 15.					

6.2.3.2	TABLE: Determination of resistive PIS			P
Location	Operating and fault condition	Dissipate power (W)		Arcing PIS? Yes / No
--	--	--		--
Supplementary information:				
Abbreviation: SC= short circuit; OC= open circuit				

8.5.5	TABLE: High pressure lamp				N/A
Lamp manufacturer	Lamp type	Explosion method	Longest axis of glass particle (mm)	Particle found beyond 1 m Yes / No	
--	--	--	--	--	
Supplementary information:					
--					

IEC 62368-1			
Clause	Requirement + Test	Result - Remark	Verdict

9.6	TABLE: Temperature measurements for wireless power transmitters								N/A
Supply voltage (V)..... :								—	
Max. transmit power of transmitter (W)..... :								—	
Foreign objects	w/o receiver and direct contact		with receiver and direct contact		with receiver and at distance of 2 mm		with receiver and at distance of 5 mm		
	Object (°C)	Ambient (°C)	Object (°C)	Ambient (°C)	Object (°C)	Ambient (°C)	Object (°C)	Ambient (°C)	
--	--	--	--	--	--	--	--	--	
Supplementary information:									
--									

5.4.1.4, 9.3, B.1.5, B.2.6	TABLE: Temperature measurements					P
Supply voltage (V)..... :	90V 60Hz	90V 60Hz	264V 50Hz	264V 50Hz	—	
Ambient temperature during test $T_{amb}$ (°C).... :	--	--	--	--	—	
Maximum measured temperature $T$ of part/at:	$T$ (°C)				Allowed $T_{max}$ (°C)	
Model: MC-682N (Loading: 11Vdc 6.2A)	Horizontal	Vertical	Horizontal	Vertical	--	
Pin holder	68.0	68.0	65.6	63.4	70	
Input wire	85.0	85.1	78.9	78.7	105	
NTC1	104.1	101.2	82.0	80.0	Ref.	
EC3	98.7	100.2	89.5	87.4	105	
CX1	93.5	96.2	88.9	86.7	100	
L1	99.1	100.6	89.7	87.3	130	
LF1	98.3	106.2	90.6	88.3	130	
T1 Coil	100.5	103.3	95.9	93.7	110	
T1 Core	99.5	102.4	94.4	93.6	110	
PCB near T1	101.0	104.6	97.5	95.3	130	
CY1	85.9	86.0	79.6	79.4	125	
PCB near D4 and D3	99.9	102.0	83.8	81.2	130	
PCB near Q3 and U3	112.0	115.0	100.8	98.5	130	
U2	91.2	92.6	85.2	84.8	100	

IEC 62368-1					
Clause	Requirement + Test		Result - Remark		Verdict
PCB near Q1	103.5	106.3	97.2	94.3	130
CE6	97.6	101.2	94.1	94.6	105
PCB near U4	86.7	88.3	81.3	82.7	130
Enclosure inside Top near T1	91.4	93.6	89.2	86.9	105
Enclosure inside Bottom near T1	80.5	83.1	78.8	76.9	105
Enclosure Outside Top near T1	77.8	80.0	77.1	74.7	--
Enclosure Outside Bottom near T1	66.0	71.0	69.7	66.7	--
Ambient	45.0	45.0	45.0	45.0	--
--	--	--	--	--	--
Enclosure Outside Top near T1	65.2	62.8	64.3	59.1	77
Enclosure Outside Bottom near T1	59.3	56.7	54.1	52.5	77
Ambient	25.0	25.0	25.0	25.0	--
Model: MC-682N (Loading: 20Vdc, 3.4A)	Horizontal	Vertical	Horizontal	Vertical	--
Pin holder	67.2	64.9	62.6	60.7	70
Input wire	84.8	79.4	75.3	74.4	105
NTC1	112.6	106.8	78.6	76.3	Ref.
EC3	100.5	93.5	86.0	83.3	105
CX1	96.7	89.3	84.8	81.9	100
L1	101.6	94.5	85.6	82.7	130
LF1	100.7	93.4	86.3	83.4	130
T1 Coil	102.4	95.1	91.7	88.5	110
T1 Core	101.0	93.4	91.0	87.8	110
PCB near T1	103.5	95.6	93.3	89.9	130
CY1	85.7	80.1	76.0	75.1	125
PCB near D4 and D3	106.3	99.7	80.5	78.0	130
PCB near Q3 and U3	109.6	101.7	97.7	94.3	130
U2	91.8	85.4	81.7	79.8	100
PCB near Q1	90.0	82.8	82.0	80.9	130
CE6	92.5	84.5	86.7	83.8	105
PCB near U4	86.3	81.3	78.2	77.6	130
Enclosure inside Top near T1	91.8	84.8	83.5	80.8	105
Enclosure inside Bottom near T1	85.5	76.4	75.4	71.3	105

IEC 62368-1							
Clause	Requirement + Test				Result - Remark		Verdict
Enclosure Outside Top near T1	76.6	70.3	69.5	67.9			--
Enclosure Outside Bottom near T1	74.3	63.2	65.9	60.4			--
Ambient	45.0	45.0	45.0	45.0			--
--	--	--	--	--			--
Enclosure Outside Top near T1	61.8	60.7	61.0	59.0			77
Enclosure Outside Bottom near T1	55.0	55.1	55.1	52.4			77
Ambient	25.0	25.0	25.0	25.0			--
Temperature T of winding:	t <sub>1</sub> (°C)	R <sub>1</sub> (Ω)	t <sub>2</sub> (°C)	R <sub>2</sub> (Ω)	T (°C)	Allowed T <sub>max</sub> (°C)	Insulation class
--	--	--	--	--	--	--	--
Supplementary information:							
* Temperature limit for TS1 of accessible enclosure according to Table 38.							
Note 1: The apparatus was submitted and evaluated for maximum manufacturer's recommended ambient (T <sub>ma</sub> ) of 45°C.							
Note 2: The temperatures were measured under the worse case normal mode defined in clause B.2.1.							
Note 3: Temperature limits are calculated as follows:							
Winding components providing safety isolation:							
Class B → T <sub>max</sub> = 120 - 10 = 110°C							
The output: 20.0V $\overline{=}$ 3.4A 68.0W MAX or 11.0V $\overline{=}$ 6.2A 68.2W MAX, the output power is the 68W or 68.2W (maintain 5 minutes) to 45W (maintain 5 minutes) to 33W(continue).							

B.2.5		TABLE: Input test							P
U (V)	Hz	I (A)	I rated (A)	P (W)	P rated (W)	Fuse No	I fuse (A)	Condition/status	
Model: MC-682N (Loading: 20Vdc 3.4A)									
90	50	1.446	--	77.01	--	F1	1.446	Rated load	
100	50	1.245	2.0	75.73	--	F1	1.245	Rated load	
240	50	0.679	2.0	74.03	--	F1	0.679	Rated load	
264	50	0.644	--	74.18	--	F1	0.644	Rated load	
90	60	1.396	--	76.51	--	F1	1.396	Rated load	
100	60	1.240	2.0	75.53	--	F1	1.240	Rated load	
240	60	0.702	2.0	74.24	--	F1	0.702	Rated load	
264	60	0.666	--	74.22	--	F1	0.666	Rated load	
Model: MC-682N (Loading: 11Vdc 6.2A)									
90	50	1.438	--	78.38	--	F1	1.438	Rated load	

IEC 62368-1								
Clause	Requirement + Test					Result - Remark		Verdict
100	50	1.299	2.0	78.52	--	F1	1.299	Rated load
240	50	0.695	2.0	75.47	--	F1	0.695	Rated load
264	50	0.662	--	75.60	--	F1	0.662	Rated load
90	60	1.449	--	79.42	--	F1	1.449	Rated load
100	60	1.289	2.0	78.44	--	F1	1.289	Rated load
240	60	0.721	2.0	75.80	--	F1	0.721	Rated load
264	60	0.684	--	75.74	--	F1	0.684	Rated load
Supplementary information:								
The maximum measured current under rated voltage did not exceed 110% of the rated current.								

B.3, B.4 TABLE: Abnormal operating and fault condition tests							P
Ambient temperature $T_{amb}$ (°C).....						25°C, if not specified	—
Power source for EUT: Manufacturer, model/type, output rating . :						--	—
Component No.	Condition	Supply voltage (V)	Test time	Fuse no.	Fuse current (A)	Observation	
Model: MC-682N							
Output (Loading: 11Vdc, 6.2A)	O-L	264	4h 05mins	F1	0.300 → 0.320 → 0.330 → 0.007	The output power is the 68.2W (maintain 5 minutes) to 45W (maintain 5 minutes) to 33W(continue). Output overload current from 3.00A to 3.20A, and shutdown at 3.22A, unit shut down, no damage, no hazard.  T1 coil: 92.1°C T1 core: 91.9°C Enclosure outside near T1 Top: 76.0°C Enclosure outside near T1 Bottom: 63.0°C Ambient: 24.8°C  Touch voltage (+ to -): 10.76V.  Touch current (“+/-” to earth): 0.080mApk.	

IEC 62368-1						
Clause	Requirement + Test				Result - Remark	Verdict
Output (Loading: 20Vdc, 3.4A)	O-L	264	4h 13mins	F1	0.298 → 0.313 → 0.317 → 0.008	The output power is the 68W (maintain 5 minutes) to 45W (maintain 5 minutes) to 33W(continue). Output overload current from 1.65A to 1.78A, and shutdown at 1.80A, unit shut down, no damage, no hazard.  T1 coil: 88.9°C T1 core: 87.7°C Enclosure outside near T1 Top: 69.4°C Enclosure outside near T1 Bottom: 59.0°C Ambient: 24.9°C  Touch voltage (+ to -): 19.58V.  Touch current ("+/-" to earth): 0.080mApk.
Model: MC-682N (Loading: 20Vdc, 3.4A)						
Output	S-C	264	10mins	F1	0.020	Unit shutdown immediately, recoverable. no hazard. Touch voltage ("+" to "-"): 0V; Touch current ("+/-" to earth): 0.080mApk.
D1	S-C	264	1s	F1	--	Fuse F1 opened immediately, no hazard. Touch voltage ("+" to "-"): 0V; Touch current ("+/-" to earth): 0.080mApk.
CE1	S-C	264	1s	F1	--	Fuse F1 opened immediately, no hazard. Touch voltage ("+" to "-"): 0V; Touch current ("+/-" to earth): 0.080mApk.
Q3 pin G-S	S-C	264	10 mins	F1	0.006	Unit shutdown immediately, recoverable. no hazard. Touch voltage ("+" to "-"): 0V; Touch current ("+/-" to earth): 0.080mApk.
Q3 pin G-D	S-C	264	1s	F1	--	Fuse F1 opened immediately, no hazard. Touch voltage ("+" to "-"): 0V; Touch current ("+/-" to earth): 0.080mApk.

IEC 62368-1						
Clause	Requirement + Test				Result - Remark	Verdict
Q3 pin S-D	S-C	264	1s	F1	--	Fuse F1 opened immediately, no hazard. Touch voltage ("+" to "-"): 0V; Touch current ("+/-" to earth): 0.080mA.
U3 pin 5-6	S-C	264	1s	F1	--	Fuse F1 opened immediately, no hazard. Touch voltage ("+" to "-"): 0V; Touch current ("+/-" to earth): 0.080mA.
U3 pin 1-6	S-C	264	10 mins	F1	0.008	Unit shutdown immediately, recoverable. no hazard. Touch voltage ("+" to "-"): 0V; Touch current ("+/-" to earth): 0.080mA.
R30	S-C	264	1s	F1	--	Fuse F1 opened immediately, no hazard. Touch voltage ("+" to "-"): 0V; Touch current ("+/-" to earth): 0.080mA.
T1 pin 1 to 3	S-C	264	10 mins	F1	0.019	Unit shutdown immediately, recoverable. no hazard. Touch voltage ("+" to "-"): 0V; Touch current ("+/-" to earth): 0.080mA.
T1 pin 7 to 8	S-C	264	10 mins	F1	0.019	Unit shutdown immediately, recoverable. no hazard. Touch voltage ("+" to "-"): 0V; Touch current ("+/-" to earth): 0.080mA.
T1 pin 5 to 6	S-C	264	10 mins	F1	0.019	Unit shutdown immediately, recoverable. no hazard. Touch voltage ("+" to "-"): 0V; Touch current ("+/-" to earth): 0.080mA.
U2 pin 1-2	S-C	264	10 mins	F1	0.020	Unit shutdown immediately, recoverable. no hazard. Touch voltage ("+" to "-"): 0V; Touch current ("+/-" to earth): 0.080mA.
U2 pin 3-4	S-C	264	10 mins	F1	0.020	Unit shutdown immediately, recoverable. no hazard. Touch voltage ("+" to "-"): 0V; Touch current ("+/-" to earth): 0.080mA.



IEC 62368-1						
Clause	Requirement + Test				Result - Remark	Verdict
U2 pin 1	O-C	264	10 mins	F1	0.020	Unit shutdown immediately, recoverable. no hazard. Touch voltage (“+” to “-”): 0V; Touch current (“+/-” to earth): 0.080mApk.
U2 pin 3	O-C	264	10 mins	F1	0.020	Unit shutdown immediately, recoverable. no hazard. Touch voltage (“+” to “-”): 0V; Touch current (“+/-” to earth): 0.080mApk.
Q2 pin D-S	S-C	264	10 mins	F1	0.019	Unit shutdown immediately, recoverable. no hazard. Touch voltage (“+” to “-”): 0V; Touch current (“+/-” to earth): 0.080mApk.
CE5	S-C	264	10 mins	F1	0.020	Unit shutdown immediately, recoverable. no hazard. Touch voltage (“+” to “-”): 0V; Touch current (“+/-” to earth): 0.080mApk.
Supplementary information:						
Test table is provided to record fault conditions for all applicable energy sources including Thermal burn injury. <ol style="list-style-type: none"> <li>1) S-C: Short-circuited; O-C: Open-circuited; O-L: Overloaded.</li> <li>2) The test result shown all safeguards remained effective, all safeguards complied with applicable requirements in this standard after restoration of normal operating conditions.</li> <li>3) The test result shown no Class 1 or 2 energy source become Class 3 level during and after single fault condition.</li> <li>4) For fuse opened condition, carried out for all sources of fuse.</li> <li>5) The overloaded condition is according to annex G.5.3.3.</li> <li>6) Winding Limit for T1 winding: 175 °C – 10 °C = 165 °C</li> </ol> The output: 20.0V=== 3.4A 68.0W MAX or 11.0V=== 6.2A 68.2W MAX, the output power is the 68W or 68.2W (maintain 5 minutes) to 45W (maintain 5 minutes) to 33W(continue).						

<b>M.3</b>	<b>TABLE: Protection circuits for batteries provided within the equipment</b>		N/A
Is it possible to install the battery in a reverse polarity position?.... :			—
Equipment Specification	Charging		
	Voltage (V)	Current (A)	
Manufacturer/type	Battery specification		
	Non-rechargeable batteries	Rechargeable batteries	

IEC 62368-1							
Clause	Requirement + Test	Result - Remark				Verdict	
	Discharging current (A)	Unintentional charging current (A)	Charging		Discharging current (A)	Reverse charging current (A)	
			Voltage (V)	Current (A)			
Note: The tests of M.3.2 are applicable only when above appropriate data is not available.							
Specified battery temperature (°C) .....							
Component No.	Fault condition	Charge/discharge mode	Test time	Temp. (°C)	Current (A)	Voltage (V)	Observation
Supplementary information:							
Abbreviation: SC= short circuit; OC= open circuit NL= no chemical leakage; NS= no spillage of liquid; NE= no explosion; NF= no emission of flame or expulsion of molten metal.							

<b>M.4.2</b>	<b>TABLE: Charging safeguards for equipment containing a secondary lithium battery</b>						<b>N/A</b>
Maximum specified charging voltage (V) .....						—	
Maximum specified charging current (A) .....						—	
Highest specified charging temperature (°C) .....							
Lowest specified charging temperature (°C) .....							
Battery manufacturer/type	Operating and fault condition	Measurement			Observation		
		Charging voltage (V)	Charging current (A)	Temp. (°C)			
Supplementary information:							
Abbreviation: SC= short circuit; OC= open circuit; MSCV= maximum specified charging voltage; MSCC= maximum specified charging current; HSCT= highest specified charging temperature; LSCT= lowest specified charging temperature							

<b>Q.1</b>	<b>TABLE: Circuits intended for interconnection with building wiring (LPS)</b>						<b>P</b>
Output Circuit	Condition	U <sub>oc</sub> (V)	Time (s)	I <sub>sc</sub> (A)		S (VA)	
				Meas.	Limit	Meas.	Limit
Model: MC-682N (Loading: 5Vdc 3A)							
Output	Normal operation	5.03	5s	3.15	8.0	15.2	100
Output	SC: U2 (pin 1-2)	0*	5s	0*	8	0*	100
Output	SC: U2 (pin 3-4)	0*	5s	0*	8	0*	100

IEC 62368-1							
Clause	Requirement + Test	Result - Remark					Verdict
Output	OC: U2 (pin 1)	0*	5s	0*	8	0*	100
Output	OC: U2 (pin 3)	0*	5s	0*	8	0*	100
Output	SC: R30	0**	5s	0**	8	0**	100
Model: MC-682N (Loading: 9Vdc 3A)							
Output	Normal operation	9.00	5s	3.15	8.0	27.5	100
Output	SC: U2 (pin 1-2)	0*	5s	0*	8	0*	100
Output	SC: U2 (pin 3-4)	0*	5s	0*	8	0*	100
Output	OC: U2 (pin 1)	0*	5s	0*	8	0*	100
Output	OC: U2 (pin 3)	0*	5s	0*	8	0*	100
Output	SC: R30	0**	5s	0**	8	0**	100
Model: MC-682N (Loading: 11Vdc 6.2A)							
Output	Normal operation	10.76	5s	6.49	8.0	65.1	100
Output	SC: U2 (pin 1-2)	0*	5s	0*	8	0*	100
Output	SC: U2 (pin 3-4)	0*	5s	0*	8	0*	100
Output	OC: U2 (pin 1)	0*	5s	0*	8	0*	100
Output	OC: U2 (pin 3)	0*	5s	0*	8	0*	100
Output	SC: R30	0**	5s	0**	8	0**	100
Model: MC-682N (Loading: 15Vdc 3A)							
Output	Normal operation	15.00	5s	3.15	8.0	46.3	100
Output	SC: U2 (pin 1-2)	0*	5s	0*	8	0*	100
Output	SC: U2 (pin 3-4)	0*	5s	0*	8	0*	100
Output	OC: U2 (pin 1)	0*	5s	0*	8	0*	100
Output	OC: U2 (pin 3)	0*	5s	0*	8	0*	100
Output	SC: R30	0**	5s	0**	8	0**	100
Model: MC-682N (Loading: 20Vdc 3.4A)							
Output	Normal operation	19.58	5s	3.61	8.0	69.2	100
Output	SC: U2 (pin 1-2)	0*	5s	0*	8	0*	100
Output	SC: U2 (pin 3-4)	0*	5s	0*	8	0*	100
Output	OC: U2 (pin 1)	0*	5s	0*	8	0*	100
Output	OC: U2 (pin 3)	0*	5s	0*	8	0*	100
Output	SC: R30	0**	5s	0**	8	0**	100
Supplementary Information:							

IEC 62368-1			
Clause	Requirement + Test	Result - Remark	Verdict

SC=Short circuit, OC=Open circuit

\* unit shutdown immediately, no hazard.

\*\* F1 open immediately. No damage, No hazard.

T.2, T.3, T.4, T.5	TABLE: Steady force test						P
Location/Part	Material	Thickness (mm)	Probe	Force (N)	Test Duration (s)	Observation	
Top side (T.4)	Plastics*	1.5	--	100	5	Enclosure remained intact, no crack/ opening developed. Internal ES3, TS3 were not accessible after test. No insulation breakdown.	
Front sides (T.4)	Plastics*	1.5	--	100	5	Enclosure remained intact, no crack/ opening developed. Internal ES3, TS3 were not accessible after test. No insulation breakdown.	
Bottom side (T.4)	Plastics*	1.5	--	100	5	Enclosure remained intact, no crack/ opening developed. Internal ES3, TS3 were not accessible after test. No insulation breakdown.	
Internal components (T.2)	--	--	--	10	5	No reduction the clearances and creepage distances	

Supplementary information:

\*See table 4.1.2 enclosure materials

Test was performed for all sources of enclosure material.

IEC 62368-1			
Clause	Requirement + Test	Result - Remark	Verdict

T.6, T.9	TABLE: Impact test				N/A
Location/Part	Material	Thickness (mm)	Height (mm)	Observation	
--	--	--	--	--	
Supplementary information:					
--					

T.7	TABLE: Drop test				P
Location/Part	Material	Thickness (mm)	Height (mm)	Observation	
Three side of enclosure	Plastics*	See table 4.1.2	1000mm	After the drop test, enclosure remained intact, no cracking/opening developed in the enclosure joint. Internal ES3, TS3 were not accessible after test. No insulation breakdown.	
Supplementary information:					
*Test were performed on product with each source listed in table 4.1.2 Test was performed for all sources of enclosure material.					

T.8	TABLE: Stress relief test					P
Location/Part	Material	Thickness (mm)	Oven Temperature (°C)	Duration (h)	Observation	
Enclosure	Plastics*	See table 4.1.2	104	7	Enclosure remained intact, no cracking/opening developed in the enclosure joint. Internal ES3, TS3 were not accessible after test. No insulation breakdown.	
Supplementary information:						
*Test were performed on product with each source listed in table 4.1.2 Test was performed for all sources of enclosure material.						

X	TABLE: Alternative method for determining minimum clearances distances	N/A
---	------------------------------------------------------------------------	-----

IEC 62368-1			
Clause	Requirement + Test	Result - Remark	Verdict
Clearance distanced between:	Peak of working voltage (V)	Required cl (mm)	Measured cl (mm)
--	--	--	--
Supplementary information:			
--			

IEC 62368-1			
Clause	Requirement + Test	Result - Remark	Verdict

4.1.2	TABLE: Critical components information					P
Object / part No.	Manufacturer/ trademark	Type / model	Technical data	Standard	Mark(s) of conformity <sup>1)</sup>	
Enclosure	LOTTE CHEMICAL CORPORATION	HN-1064 (+)	PC, V-0, 130°C, min. 1.5mm thickness, All color	UL 94, IEC 62368-1, EN IEC 62368-1	UL E115797, Tested with appliance	
(Alternative)	SABIC INNOVATIVE PLASTICS US L L C	945(GG)	PC, V-0, 120°C, min. 1.5mm thickness, All color	UL 94, IEC 62368-1, EN IEC 62368-1	UL E121562, Tested with appliance	
(Alternative)	SABIC JAPAN L L C	945(GG)	PC, V-0, 120°C, min. 1.5mm thickness, All color	UL 94, IEC 62368-1, EN IEC 62368-1	UL E207780, Tested with appliance	
(Alternative)	COVESTRO DEUTSCHLAND AG [PC RESINS]	FR6005 + (z)	PC, V-0, 105°C, min. 1.5mm thickness, All color	UL 94, IEC 62368-1, EN IEC 62368-1	UL E41613, Tested with appliance	
(Alternative)	DONGGUAN HUAZHE METALS & PLASTICS LTD	HZ-88	PC, V-0, 115°C, min. 1.5mm thickness, All color	UL 94, IEC 62368-1, EN IEC 62368-1	UL E357034, Tested with appliance	
Pin holder / Pin sleeving / ISOD pin	LOTTE CHEMICAL CORPORATION	HN-1064 (+)	V-0, 130°C	UL 94, IEC 62368-1, EN IEC 62368-1	UL E115797, Tested with appliance	
(Alternative)	SABIC INNOVATIVE PLASTICS US L L C	945(GG)	V-0, 120°C	UL 94, IEC 62368-1, EN IEC 62368-1	UL E121562, Tested with appliance	
(Alternative)	SABIC JAPAN L L C	945(GG)	V-0, 120°C	UL 94, IEC 62368-1, EN IEC 62368-1	UL E207780, Tested with appliance	
(Alternative)	COVESTRO DEUTSCHLAND AG [PC RESINS]	FR6005 + (z)	V-0, 105°C	UL 94, IEC 62368-1, EN IEC 62368-1	UL E41613, Tested with appliance	
(Alternative)	DONGGUAN HUAZHE METALS & PLASTICS LTD	HZ-88	V-0, 115°C	UL 94, IEC 62368-1, EN IEC 62368-1	UL E357034, Tested with appliance	
Insulation sheet	COVESTRO DEUTSCHLAND AG [PC RESINS]	FR6005 + (z)	PC, V-2, 105°C, min. 0.75mm thickness	UL 94, IEC 62368-1, EN IEC 62368-1	UL E41613, Tested with appliance	
(Alternative)	SABIC JAPAN L L C	945(GG)	PC, V-2, 120°C, min. 0.8mm thickness	UL 94, IEC 62368-1, EN IEC 62368-1	UL E207780, Tested with appliance	

IEC 62368-1					
Clause	Requirement + Test			Result - Remark	Verdict
(Alternative)	SABIC INNOVATIVE PLASTICS US L L C	945(GG)	PC, V-2, 120°C, min. 0.8mm thickness	UL 94, IEC 62368-1, EN IEC 62368-1	UL E121562, Tested with appliance
(Alternative)	LG CHEM (GUANGZHOU) ENGINEERING PLASTICS CO LTD	LUPOY EF- 1006F(m)(f2)	PC, V-0, 120°C, min. 1.0mm thickness	UL 94, IEC 62368-1, EN IEC 62368-1	UL E248280, Tested with appliance
EU plug	Jiangsu Chenyang Electron Co., Ltd.	MC-68-EU	250VAC, 2.0A	EN 50075:1990	Test with appliance
JP plug	Jiangsu Chenyang Electron Co., Ltd.	MC-68-JP	250VAC, 2.0A	JIS C 8303:2007	Test with appliance
UK plug	Jiangsu Chenyang Electron Co., Ltd.	MC-68-UK	250VAC, 2.0A	BS 1363-1:2016 + A1:2018	Test with appliance
Saudi plug	Jiangsu Chenyang Electron Co., Ltd.	MC-68-UK	250VAC, 2.0A	SASO 2203:2018 (Partial).	Test with appliance
AU	Jiangsu Chenyang Electron Co., Ltd.	MC-68-AU	250VAC, 2.0A	AS/NZS 3112: 2017 + A1:2021	Test with appliance
AR plug	Jiangsu Chenyang Electron Co., Ltd.	MC-68-AR	250VAC, 2.0A	IRAM 2063:2009	Test with appliance
BR plug	Jiangsu Chenyang Electron Co., Ltd.	MC-68-BR	250VAC, 2.0A	NBR 14136	Test with appliance
Internal wire	KUNSHAN XINGHONGMEN G ELECTRONIC CO LTD	3385	VW-1, Min. 105°C, 300Vac, Min. 24AWG	UL 758, IEC 62368-1, EN IEC 62368-1	UL E315421, Tested with appliance
(Alternative)	Interchangeable	Interchangeable	VW-1 or FT-1, Min. 105°C, 300Vac, Min. 24AWG	UL 758, IEC 62368-1, EN IEC 62368-1	UL, Tested with appliance
PCB	ZHENJIANG HUAYIN PRINTED CIRCUIT BOARD CO LTD	C+	V-0, 130°C	UL 94, IEC 62368-1, EN IEC 62368-1	UL E187432, Tested with appliance



IEC 62368-1					
Clause	Requirement + Test			Result - Remark	Verdict
(Alternative)	GUANGDE TONGLING ELECTRONIC CO., LTD	TL-02	V-0, 130°C	UL 94, IEC 62368-1, EN IEC 62368-1	UL E306350, Tested with appliance
(Alternative)	YANGZHOU YONGLI ELECTRONIC CO LTD	YL-01	V-0, 130°C	UL 94, IEC 62368-1, EN IEC 62368-1	UL E217102, Tested with appliance
(Alternative)	ANHUI HONGXIN ELECTRONIC TECHNOLOGY CO LTD	HX-02	V-0, 130°C	UL 94, IEC 62368-1, EN IEC 62368-1	UL E468758, Tested with appliance
(Alternative)	CHANGZHOU JITIAN ELECTRONIC CO LTD	GT-10	V-0, 130°C	UL 94, IEC 62368-1, EN IEC 62368-1	UL E315394, Tested with appliance
(Alternative)	GROW FAST DEVELOPMENT LTD	A6	V-0, 130°C	UL 94, IEC 62368-1, EN IEC 62368-1	UL E305467, Tested with appliance
(Alternative)	CHIAN YOU CO LTD	12V0-HF	V-0, 130°C	UL 94, IEC 62368-1, EN IEC 62368-1	UL E112804, Tested with appliance
(Alternative)	Interchangeable	Interchangeable	V-0, 130°C	UL 94, UL 796	UL
Fuse (F1)	SUZHOU WALTER ELECTRONIC CO LTD	ICP-Series	T3.15AL, 250VAC	IEC/EN 60127-1, IEC/EN 60127-3	VDE 40012824
(Alternative)	CONQUER ELECTRONICS CO LTD	PTU	T3.15AL, 250VAC	IEC/EN 60127-1, IEC/EN 60127-3	VDE 40001462
(Alternative)	XC Electronics (Shen Zhen) Corp. Ltd.	4T	T3.15AL, 250VAC	IEC/EN 60127-1, IEC/EN 60127-3	VDE 40029295
(Alternative)	SHENZHEN LANSON ELECTRONICS CO LTD	3N	T3.15AL, 250VAC	IEC/EN 60127-1, IEC/EN 60127-3	VDE 40016660
(Alternative)	Dongguan Better Electronics Technology Co., Ltd.,	334	T3.15AL, 250VAC	IEC/EN 60127-1, IEC/EN 60127-3	VDE 40025428

IEC 62368-1					
Clause	Requirement + Test			Result - Remark	Verdict
(Alternative)	ZHONG SHAN LANBAO ELECTRICAL APPLIANCES CO LTD	RTI-10, 1T	T3.15AL, 250VAC	IEC/EN 60127-1, IEC/EN 60127-3	VDE 40017009
Heat shrinkable tube of F1	Shenzhen Woer Heat Shrinkable Material Co., Ltd.	RSFR-H	600V, 125°C, VW-1, Min. 0.2mm thickness	UL 224, IEC 62368-1, EN IEC 62368-1	UL E203950, Tested with appliance
(Alternative)	CHANGYUAN ELECTRONICS GROUP CO LTD	CYG-ZHP	600V, 125°C, VW-1, Min. 0.2mm thickness	UL 224, IEC 62368-1, EN IEC 62368-1	UL E180908, Tested with appliance
(Alternative)	SHENZHEN XINGQI PLASTIC PRODUCTS CO LTD	X-2	600V, 125°C, VW-1, Min. 0.2mm thickness	UL 224, IEC 62368-1, EN IEC 62368-1	UL E350991, Tested with appliance
(Alternative)	DONGGUAN SALIPT CO LTD	SALIPT S-901-600	600V, 125°C, VW-1, Min. 0.2mm thickness	UL 224, IEC 62368-1, EN IEC 62368-1	UL E209436, Tested with appliance
Line filter (LF1)	JIANGSU CHENYANG ELECTRON CO., LTD.	T8*4*3	130 °C, Min. 600µH	IEC 62368-1, EN IEC 62368-1	Test with appliance
(Alternative)	SHENZHEN GREEN ELECTRONICS CO., LTD.	T8*4*3	130 °C, Min. 600µH	IEC 62368-1, EN IEC 62368-1	Test with appliance
(Alternative)	Anhui Changsheng Electronics Co., Ltd	T8*4*3	130 °C, Min. 600µH	IEC 62368-1, EN IEC 62368-1	Test with appliance
(Alternative)	ZHEJIANG JIYANG ELECTRONIC TECHNOLOGY CO LTD	T8*4*3	130 °C, Min. 600µH	IEC 62368-1, EN IEC 62368-1	Test with appliance
(Alternative)	Shenzhen Great Electronics Co., Ltd.	T8*4*3	130 °C, Min. 600µH	IEC 62368-1, EN IEC 62368-1	Test with appliance
- Magnet wire	DONG GUAN YIDA INDUSTRIAL CO LTD	QA-x/130, QA-x/155	Min. 130°C	UL 1446, IEC 62368-1, EN IEC 62368-1	UL E344055, Test with appliance

IEC 62368-1					
Clause	Requirement + Test			Result - Remark	Verdict
(Alternative)	Interchangeable	Interchangeable	Min. 130°C	UL 1446, IEC 62368-1, EN IEC 62368-1	UL, Test with appliance
-Triple insulated wire	Shanghai Hengyi Special Cable Co., Ltd.	HY-F	Min. 130°C	IEC 62368-1, EN 62368-1, DIN EN 62368-1	VDE 40042631
(Alternative)	SHENZHEN KAIZHONG HEDONG NEW MATERIALS CO LTD	TIW-B	Min. 130°C	IEC 62368-1, EN 62368-1, DIN EN 62368-1	VDE 40038861
(Alternative)	SHANGHAI XIANGXIANG ELECTRON CO LTD	TKW-B	Min. 130°C	EN 62368-1, DIN EN 62368-1	VDE 40026588
- Heat shrinkable tube	Shenzhen Woer Heat Shrinkable Material Co., Ltd.	RSFR-H	600V, 125°C, VW-1, Min. 0.2mm thickness	UL 224, IEC 62368-1, EN IEC 62368-1	UL E203950, Tested with appliance
(Alternative)	CHANGYUAN ELECTRONICS GROUP CO LTD	CYG-ZHP	600V, 125°C, VW-1, Min. 0.2mm thickness	UL 224, IEC 62368-1, EN IEC 62368-1	UL E180908, Tested with appliance
(Alternative)	SHENZHEN XINGQI PLASTIC PRODUCTS CO LTD	X-2	600V, 125°C, VW-1, Min. 0.2mm thickness	UL 224, IEC 62368-1, EN IEC 62368-1	UL E350991, Tested with appliance
(Alternative)	DONGGUAN SALIPT CO LTD	SALIPT S-901-600	600V, 125°C, VW-1, Min. 0.2mm thickness	UL 224, IEC 62368-1, EN IEC 62368-1	UL E209436, Tested with appliance
(Alternative)	Interchangeable	Interchangeable	600V, 125°C, VW-1, Min. 0.2mm thickness	UL 224, IEC 62368-1, EN IEC 62368-1	UL, Tested with appliance
Inductor (L1)	JIANGSU CHENYANG ELECTRON CO., LTD.	D5*12	130 °C, 80µH Min.	IEC 62368-1, EN IEC 62368-1	Test with appliance
(Alternative)	Anhui Changsheng Electronics Co., Ltd	D5*12	130 °C, 80µH Min.	IEC 62368-1, EN IEC 62368-1	Test with appliance
(Alternative)	HUI ZHOU DELI ELECTRONIC CO., LTD	D5*12	130 °C, 80µH Min.	IEC 62368-1, EN IEC 62368-1	Test with appliance

IEC 62368-1					
Clause	Requirement + Test			Result - Remark	Verdict
(Alternative)	JIANGMENG SHENZHEN MAGNETISM TECHNOLOGY co ltd	D5*12	130 °C, 80µH Min.	IEC 62368-1, EN IEC 62368-1	Test with appliance
(Alternative)	Ruichang Xinzhou Electronic Technology Co., Ltd	D5*12	130 °C, 80µH Min.	IEC 62368-1, EN IEC 62368-1	Test with appliance
- Magnet wire	PACIFIC ELECTRIC WIRE & CABLE (SHENZHEN) CO LTD	UEW/U@	Min. 130°C	UL 1446, IEC 62368-1, EN IEC 62368-1	UL E201757, Test with appliance
(Alternative)	Interchangeable	Interchangeable	130°C	UL 1446, IEC 62368-1, EN IEC 62368-1	UL, Test with appliance
- Heat shrinkable tube	Shenzhen Woer Heat Shrinkable Material Co., Ltd.	RSFR-H	600V, 125°C, VW-1, Min. 0.2mm thickness	UL 224, IEC 62368-1, EN IEC 62368-1	UL E203950, Tested with appliance
(Alternative)	CHANGYUAN ELECTRONICS GROUP CO LTD	CYG-ZHP	600V, 125°C, VW-1, Min. 0.2mm thickness	UL 224, IEC 62368-1, EN IEC 62368-1	UL E180908, Tested with appliance
(Alternative)	SHENZHEN XINGQI PLASTIC PRODUCTS CO LTD	X-2	600V, 125°C, VW-1, Min. 0.2mm thickness	UL 224, IEC 62368-1, EN IEC 62368-1	UL E350991, Tested with appliance
(Alternative)	DONGGUAN SALIPT CO LTD	SALIPT S-901-600	600V, 125°C, VW-1, Min. 0.2mm thickness	UL 224, IEC 62368-1, EN IEC 62368-1	UL E209436, Tested with appliance
(Alternative)	Interchangeable	Interchangeable	600V, 125°C, VW-1, Min. 0.2mm thickness	UL 224, IEC 62368-1, EN IEC 62368-1	UL, Tested with appliance
Y-capacitor (CY1, CY2)	Shantou High-New Technology Dev. Zone Songtian Enterprise Co., Ltd.	CD	Max. 150pF, min. 250Vac, 125°C, Y1 type	UL 60384-14, IEC/EN 60384-14	UL E208107, VDE 40025754
(Alternative)	Yinan Don's Electronic Component Co., Ltd.	CT81	Max. 150pF, min. 250Vac, 125°C, Y1 type	UL 60384-14, IEC/EN 60384-14	UL E145038, VDE 135256

IEC 62368-1					
Clause	Requirement + Test		Result - Remark		Verdict
(Alternative)	Anshan Kei Fat Electronic Ceramic Technical Co., Ltd.	CT7	Max. 150pF, min. 250Vac, 125°C, Y1 type	UL 60384-14, IEC/EN 60384-14	UL E232980 VDE 40036847
(Alternative)	HSUAN TAI ELECTRONICS CO LTD	CY	Max. 150pF, min. 250Vac, 125°C, Y1 type	UL 60384-14, IEC/EN 60384-14	UL E199069 VDE 40008912
(Alternative)	XIANGTAI ELECTRONIC (SHENZHEN) CO LTD	YOB, YOF, YOE (For UL); YO-series (For UL)	Max. 150pF, min. 250Vac, 125°C, Y1 type	UL 60384-14, IEC/EN 60384-14	UL E319473 VDE 40036880
(Alternative)	GUANGDONG HUIWAN ELECTRONICS TECHNOLOGY CO LTD	AR	Max. 150pF, min. 250Vac, 125°C, Y1 type	UL 60384-14, IEC/EN 60384-14	UL E480105 VDE 40043989
(Alternative)	NAN JING YUYUE ELECTRONICS CO LTD	CT7	Max. 150pF, min. 250Vac, 125°C, Y1 type	UL 60384-14, IEC/EN 60384-14	UL E237728 VDE 40008010
X-capacitor (CX1)	DAIN ELECTRONICS CO LTD	MPX	Max. 0.1µF, min. 250Vac, Min.110°C, X2	UL 60384-14, IEC/EN 60384-14	UL E147776, VDE 40018798
(Alternative)	SUCCESS ELECTRONICS CO LTD	MPX	Max. 0.1µF, min. 250Vac, Min.100°C, X2	UL 60384-14, IEC/EN 60384-14	UL E114280, VDE 40047977
(Alternative)	Shantou Bonded Area Songtian Electronics Technology Ltd.	MPX	Max. 0.1µF, min. 250Vac, Min.110°C, X2	UL 60384-14, IEC/EN 60384-14	UL E357475, VDE 40034679
(Alternative)	XIANGTAI ELECTRONIC (SHENZHEN) CO LTD	MPX	Max. 0.1µF, min. 250Vac, Min.100°C, X2	UL 60384-14, IEC/EN 60384-14	UL E208107, VDE 40036065
(Alternative)	Changzhou Jiaguan Electronics Co., Ltd.	MKP	Max. 0.1µF, min. 250Vac, Min.100°C, X2	UL 60384-14, IEC/EN 60384-14	UL E354203, VDE 40037250
Discharge resistor (R3, R4, R6, R7)	Interchangeable	Interchangeable	Each max. 2.0Mohm, 1/4W	IEC 62368-1, EN IEC 62368-1	Tested with appliance

IEC 62368-1					
Clause	Requirement + Test			Result - Remark	Verdict
Bridge rectifier (D1, D2, D3, D4)	Interchangeable	Interchangeable	Min.3A, min.1000V.	IEC 62368-1, EN IEC 62368-1	Tested with appliance
Electrolytic Capacitor (CE1, CE2)	Interchangeable	Interchangeable	22-27 $\mu$ F, min.400V, min.105°C	IEC 62368-1, EN IEC 62368-1	Tested with appliance
Electrolytic Capacitor (CE3)	Interchangeable	Interchangeable	27-33 $\mu$ F, Min. 400V, min.105°C	IEC 62368-1, EN IEC 62368-1	Tested with appliance
Current sense resistor (R30, R31)	Interchangeable	Interchangeable	0.1-0.25 $\Omega$ , min 1/4W	IEC 62368-1, EN IEC 62368-1	Tested with appliance
Thermistor (NTC)	Interchangeable	Interchangeable	Min. 2.2A, Min. 2.5ohm, at 25°C	UL 1434, IEC 62368-1, EN IEC 62368-1	UL, Tested with appliance
Heat shrinkable tube of NTC	Shenzhen Woer Heat Shrinkable Material Co., Ltd.	RSFR-H	600V, 125°C, VW-1	UL 224 IEC 62368-1, EN IEC 62368-1	UL E203950, Tested with appliance
(Alternative)	CHANGYUAN ELECTRONICS GROUP CO LTD	CYG-ZHP	600V, 125°C, VW-1	UL 224 IEC 62368-1, EN IEC 62368-1	UL E180908, Tested with appliance
(Alternative)	SHENZHEN XINGQI PLASTIC PRODUCTS CO LTD	X-2	600V, 125°C, VW-1	UL 224 IEC 62368-1, EN IEC 62368-1	UL E350991, Tested with appliance
(Alternative)	DONGGUAN SALIPT CO LTD	SALIPT S-901-600	600V, 125°C, VW-1	UL 224 IEC 62368-1, EN IEC 62368-1	UL E209436, Tested with appliance
(Alternative)	Interchangeable	Interchangeable	600V, 125°C, VW-1	UL 224, IEC 62368-1, EN IEC 62368-1	UL, Tested with appliance
Optocoupler (U2)	CT MICROELECTRONICS FAR EAST LTD	CT1019	Cr.&Cl.=min.8.0mm Dti.=min.0.4mm min. 110°C	EN 60747-5-5	VDE 40039590
(Alternative)	LITE-ON TECHNOLOGY CORP	LTV-1019	Cr.&Cl.=min.8.0mm Dti.=min.0.4mm min. 110°C	EN 60747-5-5	VDE 138213
(Alternative)	EVERLIGHT ELECTRONICS CO LTD	EL1019	Cr.&Cl.=min.8.1mm Dti.=min.0.4mm min. 110°C	EN 60747-5-5	VDE 40028391

IEC 62368-1					
Clause	Requirement + Test			Result - Remark	Verdict
Transformer (T1)	JIANGSU CHENYANG ELECTRON CO., LTD.	PQ2029-ST1	Min 130°C	Applicable parts in IEC 62368-1, EN IEC 62368-1 and according to IEC 60085.	Tested with appliance
(Alternative)	Huizhou Ruifan Technology Co Ltd	PQ2029-ST1	Min 130°C	Applicable parts in IEC 62368-1, EN IEC 62368-1 and according to IEC 60085.	Tested with appliance
(Alternative)	CHONGQING JINLAI TECHNOLOGY CORP	PQ2029-ST1	Min 130°C	Applicable parts in IEC 62368-1, EN IEC 62368-1 and according to IEC 60085.	Tested with appliance
(Alternative)	ZHEJIANG WANYANG ELECTRONICS CO LTD	PQ2029-ST1	Min 130°C	Applicable parts in IEC 62368-1, EN IEC 62368-1 and according to IEC 60085.	Tested with appliance
(Alternative)	HeFei Phoenix Electronics Technology Co Ltd	PQ2029-ST1	Min 130°C	Applicable parts in IEC 62368-1, EN IEC 62368-1 and according to IEC 60085.	Tested with appliance
(Alternative)	SHENZHEN HFGC ELECTRONIC CO LTD DONGGUAN BRANC	PQ2029-ST1	Min 130°C	Applicable parts in IEC 62368-1, EN IEC 62368-1 and according to IEC 60085.	Tested with appliance
(Alternative)	GUANGDONG LIWANG HIGH-TECH CO LTD	PQ2029-ST1	Min 130°C	Applicable parts in IEC 62368-1, EN IEC 62368-1 and according to IEC 60085.	Tested with appliance
(Alternative)	SHENZHEN FORD ELECTRONIC CO LTD	PQ2029-ST1	Min 130°C	Applicable parts in IEC 62368-1, EN IEC 62368-1 and according to IEC 60085.	Tested with appliance
Component used in T1					
- Bobbin	Sumitomo Bakelite Co Ltd	PM-9820, PM-9630, PM-9823	Phenolic, V-0, 150 °C, min. 0.71 mm thickness	UL 94, IEC 62368-1, EN IEC 62368-1	UL E41429, Test with appliance

IEC 62368-1					
Clause	Requirement + Test			Result - Remark	Verdict
(Alternative)	Chang Chun Plastics Co Ltd	T375J, T373J, T200HF, T220NA, T375HF	Phenolic, V-0, 150 °C, min. 0.71 mm thickness	UL 94, IEC 62368-1, EN IEC 62368-1	UL E59481, Test with appliance
- Magnet wire	TAI-I Electric Wire & Cable	UEW	130°C	UL 1446, IEC 62368-1, EN IEC 62368-1	UL E85640, Test with appliance
(Alternative)	Interchangeable	Interchangeable	130°C	UL 1446, IEC 62368-1, EN IEC 62368-1	UL, Test with appliance
-Triple insulated wire	FURUKAWA ELECTRIC CO LTD	TEX-E, TEX- EA for UL, TEX-E for VDE	Min.130 °C	UL 2353, IEC 62368-1, EN 62368-1, DIN EN 62368-1	UL E206440, VDE 006735
(Alternative)	TOTOKU ELECTRIC CO LTD	TIW-2SX\$+, TIW-2SXY\$+, TIW-2LZX\$+, TIW-2LZXY\$+ for UL, TIW-2S, TIW-2 xx yy, TIW-2 LZ xx yy for VDE	Min.130 °C	UL 2353, IEC 62368-1, EN 62368-1, DIN EN 62368-1	UL E166483, VDE 40052059, VDE 40051990
(Alternative)	KBI COSMOLINK CO., LTD.	TIW-M	Min.130 °C	UL 2353, IEC 62368-1, EN 62368-1, DIN EN 62368-1	UL E213764 VDE 138053
(Alternative)	Shanghai Xiangxiang Electron Co Ltd	TKW-B	Min.130 °C	UL 2353, IEC 62368-1, EN 62368-1, DIN EN 62368-1	UL E308908 VDE 40026588
(Alternative)	SHENZHEN KAIZHONG HEDONG NEW MATERIAL CO LTD	TIW-B	Min.130 °C	UL 2353, EN 62368-1, DIN EN 62368-1	UL E357240 VDE 40038861



IEC 62368-1					
Clause	Requirement + Test		Result - Remark		Verdict
(Alternative)	SUZHOU YUSHENG ELECTRONIC CO LTD	FIW-B*, YSW-B*, FLW-B*, FIW-F*, YSW-F*, FLW-F*, FLW- B*(LZ)@+, FLW-B-SB*, FLW- F*(LZ)@+, FLW-F*@+, FLW-F-SB*, FLW-H*+, TIW-B*, TWE-3*, TIW-B*4, TIW-F*, TWE-F*	Min. 130 °C	UL 2353,	UL E332529
		YSWP-B*+, FLW-B, YSWP-F*+, FLW-F, FLW-B(LZ), FLW-B-SB, FLW-F*(LZ)@, FLW-F-SB, TIW-B(LZ), TWE-3, TIW-B, TIW-F, TWE-F	Min. 130 °C	IEC 62368-1, EN 62368-1, DIN EN 62368-1	VDE 40033527
(Alternative)	TOTOKU ELECTRIC CO LTD	TIW- 3LZX@@@% \$+, TIW-3X\$+ for UL, TIW-3 xx yy, TIW-3 LZ xx yy for VDE	Min. 130 °C	UL 2353, IEC 62368-1, EN 62368-1, DIN EN 62368-1	UL E166483, VDE 40051888
(Alternative)	YOUNG CHANG SILICONE CO., LIMITED	STW-B	Min. 130 °C	UL 2353, IEC 62368-1, EN 62368-1, DIN EN 62368-1	UL E242198, VDE 40013359
(Alternative)	NEW ENGLAND WIRE TECHNOLOGIES CORP	WaaScccExxx xxxxxxxxx+ for UL, TEFLON FEP (3) Serie(s) for VDE	Min. 130 °C	UL 2353, IEC 62368-1, EN 62368-1, DIN EN 62368-1	UL E205791, VDE 135441

IEC 62368-1					
Clause	Requirement + Test			Result - Remark	Verdict
- Insulation tape	JINGJIANG YAHUA PRESSURE SENSITIVE GLUE CO., LTD.	CT*(b)(g), CT*(c)(g), CT-280B, PZ*(b), WF*(c)(h)	Min. 130°C	UL 510A, IEC 62368-1, EN IEC 62368-1	UL E165111, Tested with apparatus
(Alternative)	Dongguan Shin Yahua Electronic Material Co., Ltd	CT*(b)(g), CT*(c)(g), PZ*(b), WF*(c)(h)	Min. 130°C	UL 510A, IEC 62368-1, EN IEC 62368-1	UL E324093, Tested with apparatus
(Alternative)	Jingjiang Yahua Electronic Science&Technol ogy Co., Ltd.	CT(b)1, WF- 2901/2(a)	Min. 130°C	UL 510A, IEC 62368-1, EN IEC 62368-1	UL E478268, Tested with apparatus
(Alternative)	Jingjiang Fuwei Adhesive Product Co., Ltd	FW, WF101	Min. 130°C	UL 510A, IEC 62368-1, EN IEC 62368-1	UL E302608, Tested with apparatus
(Alternative)	Jingjiang Jingyang Insulating Product Co., Ltd	JY-133, JY- 233	Min. 130°C	UL 510A, IEC 62368-1, EN IEC 62368-1	UL E309872, Tested with apparatus
(Alternative)	Jingjiang Jingyi Adhesive Product Co., Ltd	JY25-A(b), WF310(a)	Min. 130°C	UL 510A, IEC 62368-1, EN IEC 62368-1	UL E246950, Tested with apparatus
(Alternative)	Shenzhen Shengdafeng Electronic Material Co Ltd	SDF-312	Min. 130°C	UL 510A, IEC 62368-1, EN IEC 62368-1	UL E526813, Tested with apparatus
(Alternative)	3M COMPANY	1350-1 (b), 1350F-1 (b)	Min. 130°C	UL 510A, IEC 62368-1, EN IEC 62368-1	UL E17385, Tested with apparatus
(Alternative)	DUCK SUNG HITECH CO LTD	DTS-204 (e), DTS-204K (f), DTS-241, DTS-280	Min. 130°C	UL 510A, IEC 62368-1, EN IEC 62368-1	UL E105147, Tested with apparatus

IEC 62368-1					
Clause	Requirement + Test			Result - Remark	Verdict
(Alternative)	CHANG SHU LIANG YI TAPE INDUSTRY CO LTD	LY-19-01-15a, LY-19-01-18a, LY-19-01-20a, LY-19-01-25a, LY-19-01-40a, LY-19-01-85a, LY-19-02-15b, LY-19-02-18b, LY-19-02-20b, LY-19-02-25b, LY-19-02-40b, LY-19-02-85b, LY-XX*, LY0-08 (f)(g), LY0-XX (f)(g) (except LY0-08)	Min. 130°C	UL 510A, IEC 62368-1, EN IEC 62368-1	UL E246820, Tested with apparatus
Supplementary information:					
1) Provided evidence ensures the agreed level of compliance. See OD-CB2039.					
2) License available upon request.					

IEC62368_1E - ATTACHMENT			
Clause	Requirement + Test	Result - Remark	Verdict
<b>ATTACHMENT TO TEST REPORT</b> <b>IEC 62368-1</b> <b>EUROPEAN GROUP DIFFERENCES AND NATIONAL DIFFERENCES</b> (Audio/video, information and communication technology equipment - Part 1: Safety requirements)			
Differences according to ..... : EN IEC 62368-1:2020+A11:2020			
Attachment Form No..... : EU_GD_IEC62368_1E			
Attachment Originator..... : UL(Demko)			
Master Attachment..... : 2021-02-04			
Copyright © 2021 IEC System for Conformity Testing and Certification of Electrical Equipment (IECEE), Geneva, Switzerland. All rights reserved.			
	<b>CENELEC COMMON MODIFICATIONS (EN)</b>		P
	Clause numbers in the cells that are shaded light grey are clause references in EN IEC 62368-1:2020+A11:2020. All other clause numbers in that column, except for those in the paragraph below, refers to IEC 62368-1:2018.  Clauses, subclauses, notes, tables, figures and annexes which are additional to those in IEC 62368-1:2018 are prefixed "Z".		P
	Add the following annexes: Annex ZA (normative) Normative references to international publications with their corresponding European publications Annex ZB (normative) Special national conditions Annex ZC (informative) A-deviations Annex ZD (informative) IEC and CENELEC code designations for flexible cords		P
<b>1</b>	<b>Modification to Clause 3 .</b>		
<b>3.3.19</b>	<b>Sound exposure</b> <i>Replace 3.3.19 of IEC 62368-1 with the following definitions:</i>		N/A

IEC 62368-1			
Clause	Requirement + Test	Result - Remark	Verdict
3.3.19.1	<p><b>momentary exposure level, MEL</b></p> <p>metric for estimating 1 s sound exposure level from the HD 483-1 S2 test signal applied to both channels, based on EN 50332-1:2013, 4.2.</p> <p>Note 1 to entry: MEL is measured as A-weighted levels in dB. Note 2 to entry: See B.3 of EN 50332-3:2017 for additional information.</p>	Not Video equipment	N/A
3.3.19.3	<p><b>sound exposure, E</b></p> <p>A-weighted sound pressure (<math>p</math>) squared and integrated over a stated period of time, <math>T</math></p> <p>Note 1 to entry: The SI unit is Pa<sup>2</sup>s.</p> $E = \int_0^T p(t)^2 dt$		N/A
3.3.19.4	<p><b>sound exposure level, SEL</b></p> <p>logarithmic measure of sound exposure relative to a reference value, <math>E_0</math>, typically the 1 kHz threshold of hearing in humans.</p> <p>Note 1 to entry: SEL is measured as A-weighted levels in dB.</p> $SEL = 10 \lg \left( \frac{E}{E_0} \right) \text{ dB}$ <p>Note 2 to entry: See B.4 of EN 50332-3:2017 for additional information.</p>		N/A
3.3.19.5	<p><b>digital signal level relative to full scale, dBFS</b></p> <p>levels reported in dBFS are always r.m.s. Full scale level, 0 dBFS, is the level of a dc-free 997-Hz sine wave whose undithered positive peak value is positive digital full scale, leaving the code corresponding to negative digital full scale unused</p> <p>Note 1 to entry: It is invalid to use dBFS for non-r.m.s. levels. Because the definition of full scale is based on a sine wave, the level of signals with a crest factor lower than that of a sine wave may exceed 0 dBFS. In particular, square wave signals may reach +3,01 dBFS.</p>		N/A
2	<b>Modification to Clause 10</b>		
10.6	<b>Safeguards against acoustic energy sources</b> Replace 10.6 of IEC 62368-1 with the following:		N/A
10.6.1.1	<p><b>Introduction</b></p> <p><b>Safeguard</b> requirements for protection against long-term exposure to excessive sound pressure</p>		N/A

IEC 62368-1			
Clause	Requirement + Test	Result - Remark	Verdict
	<p>levels from personal music players closely coupled to the ear are specified below. Requirements for earphones and headphones intended for use with personal music players are also covered. A personal music player is a portable equipment intended for use by an <b>ordinary person</b>, that:</p> <ul style="list-style-type: none"> <li>– is designed to allow the user to listen to audio or audiovisual content / material; and</li> <li>– uses a listening device, such as headphones or earphones that can be worn in or on or around the ears; and</li> <li>– has a player that can be body worn (of a size suitable to be carried in a clothing pocket) and is intended for the user to walk around with while in continuous use (for example, on a street, in a subway, at an airport, etc.).</li> </ul> <p>EXAMPLES Portable CD players, MP3 audio players, mobile phones with MP3 type features, PDAs or similar equipment.</p> <p>Personal music players shall comply with the requirements of either 10.6.2 or 10.6.3.</p> <p>NOTE 1 Protection against acoustic energy sources from telecom applications is referenced to ITU-T P.360.</p> <p>NOTE 2 It is the intention of the Committee to allow the alternative methods for now, but to only use the dose measurement method as given in 10.6.5 in future. Therefore, manufacturers are encouraged to implement 10.6.5 as soon as possible.</p> <p>Listening devices sold separately shall comply with the requirements of 10.6.6.                      These requirements are valid for music or video mode only.                      The requirements do not apply to:</p> <ul style="list-style-type: none"> <li>– professional equipment;</li> </ul> <p>NOTE 3 Professional equipment is equipment sold through special sales channels. All products sold through normal electronics stores are considered not to be professional equipment.</p> <ul style="list-style-type: none"> <li>– hearing aid equipment and other devices for assistive listening;</li> <li>– the following type of analogue personal music players:                             <ul style="list-style-type: none"> <li>• long distance radio receiver (for example, a multiband radio receiver or world band radio receiver, an AM radio receiver), and</li> <li>• cassette player/recorder;</li> </ul> </li> </ul> <p>NOTE 4 This exemption has been allowed because this technology is falling out of use and it is expected that within a few years it will no longer exist. This exemption will not be extended to other technologies.</p>		

IEC 62368-1			
Clause	Requirement + Test	Result - Remark	Verdict
	<p>– a player while connected to an external amplifier that does not allow the user to walk around while in use.</p> <p>For equipment that is clearly designed or intended primarily for use by children, the limits of the relevant toy standards may apply.</p> <p>The relevant requirements are given in EN 71-1:2011, 4.20 and the related tests methods and measurement distances apply.</p>		
<b>10.6.1.2</b>	<p><b>Non-ionizing radiation from radio frequencies in the range 0 to 300 GHz</b></p> <p>The amount of non-ionizing radiation is regulated by European Council Recommendation 1999/519/EC of 12 July 1999 on the limitation of exposure of the general public to electromagnetic fields (0 Hz to 300 GHz). For intentional radiators, ICNIRP guidelines should be taken into account for Limiting Exposure to Time-Varying Electric, Magnetic, and Electromagnetic Fields (up to 300 GHz). For hand-held and body mounted devices, attention is drawn to EN 50360 and EN 50566.</p>		N/A
<b>10.6.2</b>	<b>Classification of devices without the capacity to estimate sound dose</b>		N/A
<b>10.6.2.1</b>	<p><b>General</b></p> <p>This standard is transitioning from short-term based (30 s) requirements to long-term based (40 hour) requirements. These clauses remain in effect only for devices that do not comply with sound dose estimation as stipulated in EN 50332-3.</p> <p>For classifying the acoustic output <math>L_{Aeq,T}</math>, measurements are based on the A-weighted equivalent sound pressure level over a 30 s period.</p> <p>For music where the average sound pressure (long term <math>L_{Aeq,\tau}</math>) measured over the duration of the song is lower than the average produced by the programme simulation noise, measurements may be done over the duration of the complete song. In this case, <math>T</math> becomes the duration of the song.</p> <p>NOTE Classical music, acoustic music and broadcast typically has an average sound pressure (long term <math>L_{Aeq,\tau}</math>) which is much lower than the average programme simulation noise. Therefore, if the player is capable to analyse the content and compare it with the programme simulation noise, the warning does not need to be given as long as the average sound pressure of the song does not exceed the required limit. For example, if the player is set with the programme simulation noise to 85 dB, but the average music level of the song is only 65 dB, there is no need to give a warning or ask an</p>		N/A

IEC 62368-1			
Clause	Requirement + Test	Result - Remark	Verdict
	acknowledgement as long as the average sound level of the song is not above the basic limit of 85 dB.		
10.6.2.2	<p><b>RS1 limits (to be superseded, see 10.6.3.2)</b></p> <p>RS1 is a class 1 acoustic energy source that does not exceed the following:</p> <ul style="list-style-type: none"> <li>– for equipment provided as a package (player with its listening device), and with a proprietary connector between the player and its listening device, or where the combination of player and listening device is known by other means such as setting or automatic detection, the <math>L_{Aeq,T}</math> acoustic output shall be <math>\leq 85</math> dB when playing the fixed “programme simulation noise” described in EN 50332-1.</li> <li>– for equipment provided with a standardized connector (for example, a 3,5 phone jack) that allows connection to a listening device for general use, the unweighted r.m.s. output voltage shall be <math>\leq 27</math> mV (analogue interface) or -25 dBFS (digital interface) when playing the fixed “programme simulation noise” described in EN 50332-1.</li> <li>– The RS1 limits will be updated for all devices as per 10.6.3.2.</li> </ul>		N/A
10.6.2.3	<p><b>RS2 limits (to be superseded, see 10.6.3.3)</b></p> <p>RS2 is a class 2 acoustic energy source that does not exceed the following:</p> <ul style="list-style-type: none"> <li>– for equipment provided as a package (player with its listening device), and with a proprietary connector between the player and its listening device, or when the combination of player and listening device is known by other means such as setting or automatic 130 detection, the <math>L_{Aeq,T}</math> acoustic output shall be <math>\leq 100</math> dB(A) when playing the fixed “programme simulation noise” as described in EN 50332-1.</li> <li>– for equipment provided with a standardized connector (for example, a 3,5 phone jack) that allows connection to a listening device for general use, the unweighted r.m.s. output voltage shall be <math>\leq 150</math> mV (analogue interface) or -10 dBFS (digital interface) when playing the fixed “programme simulation noise” as described in EN 50332-1.</li> </ul>		N/A
10.6.2.4	<p><b>RS3 limits</b></p> <p>RS3 is a class 3 acoustic energy source that exceeds RS2 limits.</p>		N/A
10.6.3	<b>Classification of devices (new)</b>		N/A
10.6.3.1	<p><b>General</b></p> <p>Previous limits (10.6.2) created abundant false negative and false positive PMP sound level</p>		N/A



IEC 62368-1			
Clause	Requirement + Test	Result - Remark	Verdict
	warnings. New limits, compliant with The Commission Decision of 23 June 2009, are given below.		
<b>10.6.3.2</b>	<p><b>RS1 limits (new)</b></p> <p>RS1 is a class 1 acoustic energy source that does not exceed the following:</p> <ul style="list-style-type: none"> <li>– for equipment provided as a package (player with its listening device), and with a proprietary connector between the player and its listening device, or where the combination of player and listening device is known by other means such as setting or automatic detection, the <math>L_{Aeq,T}</math> acoustic output shall be <math>\leq 80</math> dB when playing the fixed "programme simulation noise" described in EN 50332-1.</li> <li>– for equipment provided with a standardized connector (for example, a 3,5 phone jack) that allows connection to a listening device for general use, the unweighted r.m.s. output voltage shall be <math>\leq 15</math> mV (analogue interface) or -30 dBFS (digital interface) when playing the fixed "programme simulation noise" described in EN 50332-1.</li> </ul>		N/A
<b>10.6.3.3</b>	<p><b>RS2 limits (new)</b></p> <p>RS2 is a class 2 acoustic energy source that does not exceed the following:</p> <ul style="list-style-type: none"> <li>– for equipment provided as a package (player with its listening device), and with a proprietary connector between the player and its listening device, or where the combination of player and listening device is known by other means such as setting or automatic detection, the weekly sound exposure level, as described in EN 50332-3, shall be <math>\leq 80</math> dB when playing the fixed "programme simulation noise" described in EN 50332-1.</li> <li>– for equipment provided with a standardized connector (for example, a 3,5 phone jack) that allows connection to a listening device for general use, the unweighted r.m.s. output level, integrated over one week, as described in EN50332-3, shall be <math>\leq 15</math> mV (analogue interface) or -30 dBFS (digital interface) when playing the fixed "programme simulation noise" described in EN 50332-1.</li> </ul>		N/A
<b>10.6.4</b>	<b>Requirements for maximum sound exposure</b>		N/A
<b>10.6.4.1</b>	<p><b>Measurement methods</b></p> <p>All volume controls shall be turned to maximum during tests.</p> <p>Measurements shall be made in accordance with EN 50332-1 or EN 50332-2 as applicable.</p>		N/A

IEC 62368-1			
Clause	Requirement + Test	Result - Remark	Verdict
10.6.4.2	<p><b>Protection of persons</b></p> <p>Except as given below, protection requirements for parts <b>accessible to ordinary persons, instructed persons</b> and <b>skilled persons</b> are given in 4.3.</p> <p>NOTE 1 Volume control is not considered a <b>safeguard</b>.</p> <p>Between RS2 and an <b>ordinary person</b>, the <b>basic safeguard</b> may be replaced by an <b>instructional safeguard</b> in accordance with Clause F.5, except that the <b>instructional safeguard</b> shall be placed on the equipment, or on the packaging, or in the instruction manual.</p> <p>Alternatively, the <b>instructional safeguard</b> may be given through the equipment display during use.</p> <p>The elements of the <b>instructional safeguard</b> shall be as follows:</p> <ul style="list-style-type: none"> <li>– element 1a: the symbol , IEC 60417-6044 (2011-01)</li> <li>– element 2: “High sound pressure” or equivalent wording</li> <li>– element 3: “Hearing damage risk” or equivalent wording</li> <li>– element 4: “Do not listen at high volume levels for long periods.” or equivalent wording</li> </ul> <p>An <b>equipment safeguard</b> shall prevent exposure of an <b>ordinary person</b> to an RS2 source without intentional physical action from the <b>ordinary person</b> and shall automatically return to an output level not exceeding what is specified for an RS1 source when the power is switched off.</p> <p>The equipment shall provide a means to actively inform the user of the increased sound level when the equipment is operated with an output exceeding RS1. Any means used shall be acknowledged by the user before activating a mode of operation which allows for an output exceeding RS1. The acknowledgement does not need to be repeated more than once every 20 h of cumulative listening time.</p> <p>NOTE 2 Examples of means include visual or audible signals. Action from the user is always needed.</p> <p>NOTE 3 The 20 h listening time is the accumulative listening time, independent of how often and how long the personal music player has been switched off.</p> <p>A <b>skilled person</b> shall not be unintentionally exposed to RS3.</p>		N/A

IEC 62368-1			
Clause	Requirement + Test	Result - Remark	Verdict
<b>10.6.5</b>	<b>Requirements for dose-based systems</b>		N/A
<b>10.6.5.1</b>	<p><b>General requirements</b></p> <p>Personal music players shall give the warnings as provided below when tested according to EN 50332-3, using the limits from this clause.</p> <p>The manufacturer may offer optional settings to allow the users to modify when and how they wish to receive the notifications and warnings to promote a better user experience without defeating the safeguards. This allows the users to be informed in a method that best meets their physical capabilities and device usage needs. If such optional settings are offered, an administrator (for example, parental restrictions, business/educational administrators, etc.) shall be able to lock any optional settings into a specific configuration.</p> <p>The personal music player shall be supplied with easy to understand explanation to the user of the dose management system, the risks involved, and how to use the system safely. The user shall be made aware that other sources may significantly contribute to their sound exposure, for example work, transportation, concerts, clubs, cinema, car races, etc.</p>		N/A
<b>10.6.5.2</b>	<p><b>Dose-based warning and requirements</b></p> <p>When a dose of 100 % <i>CSD</i> is reached, and at least at every 100 % further increase of <i>CSD</i>, the device shall warn the user and require an acknowledgement. In case the user does not acknowledge, the output level shall automatically decrease to compliance with class RS1.</p> <p>The warning shall at least clearly indicate that listening above 100 % <i>CSD</i> leads to the risk of hearing damage or loss.</p>		N/A
<b>10.6.5.3</b>	<p><b>Exposure-based requirements</b></p> <p>With only dose-based requirements, cause and effect could be far separated in time, defying the purpose of educating users about safe listening practice. In addition to dose-based requirements, a PMP shall therefore also put a limit to the short-term sound level a user can listen at.</p> <p>The exposure-based limiter (EL) shall automatically reduce the sound level not to exceed 100 dB(A) or 150 mV integrated over the past 180 s, based on methodology defined in EN 50332-3.</p> <p>The EL settling time (time from starting level</p>		N/A

IEC 62368-1			
Clause	Requirement + Test	Result - Remark	Verdict
	<p>reduction to reaching target output) shall be 10 s or faster.</p> <p>Test of EL functionality is conducted according to EN 50332-3, using the limits from this clause. For equipment provided as a package (player with its listening device), the level integrated over 180 s shall be 100 dB or lower. For equipment provided with a standardized connector, the unweighted level integrated over 180 s shall be no more than 150 mV for an analogue interface and no more than -10 dBFS for a digital interface.</p> <p>NOTE In case the source is known not to be music (or test signal), the EL may be disabled.</p>		

<b>10.6.6</b>	<b>Requirements for listening devices (headphones, earphones, etc.)</b>		N/A
<b>10.6.6.1</b>	<p><b>Corded listening devices with analogue input</b></p> <p>With 94 dB <math>L_{Aeq}</math> acoustic pressure output of the listening device, and with the volume and sound settings in the listening device (for example, built-in volume level control, additional sound features like equalization, etc.) set to the combination of positions that maximize the measured acoustic output, the input voltage of the listening device when playing the fixed “programme simulation noise” as described in EN 50332-1 shall be <math>\geq 75</math> mV.</p> <p>NOTE The values of 94 dB and 75 mV correspond with 85 dB and 27 mV or 100 dB and 150 mV.</p>		N/A
<b>10.6.6.2</b>	<p><b>Corded listening devices with digital input</b></p> <p>With any playing device playing the fixed “programme simulation noise” described in EN 50332-1, and with the volume and sound settings in the listening device (for example, built-in volume level control, additional sound features like equalization, etc.) set to the combination of positions that maximize the measured acoustic output, the <math>L_{Aeq, T}</math> acoustic output of the listening device shall be <math>\leq 100</math> dB with an input signal of -10 dBFS.</p>		N/A
<b>10.6.6.3</b>	<p><b>Cordless listening devices</b></p> <p>In cordless mode,</p> <ul style="list-style-type: none"> <li>– with any playing and transmitting device playing the fixed programme simulation noise described in EN 50332-1; and</li> <li>– respecting the cordless transmission standards, where an air interface standard exists that specifies the equivalent acoustic level; and</li> </ul>		N/A

IEC 62368-1																																																															
Clause	Requirement + Test	Result - Remark	Verdict																																																												
	– with volume and sound settings in the receiving device (for example, built-in volume level control, additional sound features like equalization, etc.) set to the combination of positions that maximize the measured acoustic output for the above mentioned programme simulation noise, the $L_{Aeq,T}$ acoustic output of the listening device shall be $\leq 100$ dB with an input signal of -10 dBFS.																																																														
<b>10.6.6.4</b>	<b>Measurement method</b>  <i>Measurements shall be made in accordance with EN 50332-2 as applicable.</i>		N/A																																																												
<b>3</b>	<b>Modification to the whole document</b>																																																														
	<p><b>Delete</b> all the “country” notes in the reference document according to the following list:</p> <table border="1"> <tbody> <tr> <td>0.2.1</td> <td>Note 1 and 2</td> <td>1</td> <td>Note 4 and 5</td> <td>3.3.8.1</td> <td>Note 2</td> </tr> <tr> <td>3.3.8.3</td> <td>Note 1</td> <td>4.1.15</td> <td>Note</td> <td>4.7.3</td> <td>Note 1 and 2</td> </tr> <tr> <td>5.2.2.2</td> <td>Note</td> <td>5.4.2.3.2.2 Table 12</td> <td>Note c</td> <td>5.4.2.3.2.4</td> <td>Note 1 and 3</td> </tr> <tr> <td>5.4.2.3.2.4 Table 13</td> <td>Note 2</td> <td>5.4.2.5</td> <td>Note 2</td> <td>5.4.5.1</td> <td>Note</td> </tr> <tr> <td>5.4.10.2.1</td> <td>Note</td> <td>5.4.10.2.2</td> <td>Note</td> <td>5.4.10.2.3</td> <td>Note</td> </tr> <tr> <td>5.5.2.1</td> <td>Note</td> <td>5.5.6</td> <td>Note</td> <td>5.6.4.2.1</td> <td>Note 2 and 3 and 4</td> </tr> <tr> <td>5.6.8</td> <td>Note 2</td> <td>5.7.6</td> <td>Note</td> <td>5.7.7.1</td> <td>Note 1 and Note 2</td> </tr> <tr> <td>8.5.4.2.3</td> <td>Note</td> <td>10.2.1 Table 39</td> <td>Note 3 and 4 and 5</td> <td>10.5.3</td> <td>Note 2</td> </tr> <tr> <td><del>10.6.1</del></td> <td>Note 3</td> <td>F.3.3.6</td> <td>Note 3</td> <td>Y.4.1</td> <td>Note</td> </tr> <tr> <td>Y.4.5</td> <td>Note</td> <td></td> <td></td> <td></td> <td></td> </tr> </tbody> </table>		0.2.1	Note 1 and 2	1	Note 4 and 5	3.3.8.1	Note 2	3.3.8.3	Note 1	4.1.15	Note	4.7.3	Note 1 and 2	5.2.2.2	Note	5.4.2.3.2.2 Table 12	Note c	5.4.2.3.2.4	Note 1 and 3	5.4.2.3.2.4 Table 13	Note 2	5.4.2.5	Note 2	5.4.5.1	Note	5.4.10.2.1	Note	5.4.10.2.2	Note	5.4.10.2.3	Note	5.5.2.1	Note	5.5.6	Note	5.6.4.2.1	Note 2 and 3 and 4	5.6.8	Note 2	5.7.6	Note	5.7.7.1	Note 1 and Note 2	8.5.4.2.3	Note	10.2.1 Table 39	Note 3 and 4 and 5	10.5.3	Note 2	<del>10.6.1</del>	Note 3	F.3.3.6	Note 3	Y.4.1	Note	Y.4.5	Note					P
0.2.1	Note 1 and 2	1	Note 4 and 5	3.3.8.1	Note 2																																																										
3.3.8.3	Note 1	4.1.15	Note	4.7.3	Note 1 and 2																																																										
5.2.2.2	Note	5.4.2.3.2.2 Table 12	Note c	5.4.2.3.2.4	Note 1 and 3																																																										
5.4.2.3.2.4 Table 13	Note 2	5.4.2.5	Note 2	5.4.5.1	Note																																																										
5.4.10.2.1	Note	5.4.10.2.2	Note	5.4.10.2.3	Note																																																										
5.5.2.1	Note	5.5.6	Note	5.6.4.2.1	Note 2 and 3 and 4																																																										
5.6.8	Note 2	5.7.6	Note	5.7.7.1	Note 1 and Note 2																																																										
8.5.4.2.3	Note	10.2.1 Table 39	Note 3 and 4 and 5	10.5.3	Note 2																																																										
<del>10.6.1</del>	Note 3	F.3.3.6	Note 3	Y.4.1	Note																																																										
Y.4.5	Note																																																														
<b>4</b>	<b>Modification to Clause 1</b>																																																														
<b>1</b>	<p><b>Add the following note:</b></p> <p><i>NOTE Z1 The use of certain substances in electrical and electronic equipment is restricted within the EU: see Directive 2011/65/EU.</i></p>		P																																																												
<b>5</b>	<b>Modification to 4.Z1</b>																																																														

IEC 62368-1			
Clause	Requirement + Test	Result - Remark	Verdict
<b>4.Z1</b>	<p><b>Add the following new subclause after 4.9:</b></p> <p>To protect against excessive current, short-circuits and earth faults in circuits connected to an a.c. <b>mains</b>, protective devices shall be included either as integral parts of the equipment or as parts of the building installation, subject to the following, a), b) and c):</p> <p>a) except as detailed in b) and c), protective devices necessary to comply with the requirements of B.3.1 and B.4 shall be included as parts of the equipment;</p> <p>b) for components in series with the mains input to the equipment such as the supply cord, appliance coupler, r.f.i. filter and switch, short-circuit and earth fault protection may be provided by protective devices in the building installation;</p> <p>c) it is permitted for <b>pluggable equipment type B</b> or <b>permanently connected equipment</b>, to rely on dedicated overcurrent and short-circuit protection in the building installation, provided that the means of protection, e.g. fuses or circuit breakers, is fully specified in the installation instructions.</p> <p>If reliance is placed on protection in the building installation, the installation instructions shall so state, except that for <b>pluggable equipment type A</b> the building installation shall be regarded as providing protection in accordance with the rating of the wall socket outlet.</p>	See below.	P
<b>6</b>	<b>Modification to 5.4.2.3.2.4</b>		
<b>5.4.2.3.2.4</b>	<p><b>Add the following to the end of this subclause:</b></p> <p>The requirement for interconnection with <b>external circuit</b> is in addition given in EN 50491-3:2009.</p>	No external circuits.	N/A
<b>7</b>	<b>Modification to 10.2.1</b>		
<b>10.2.1</b>	<p>Add the following to <sup>o)</sup> and <sup>o)</sup> in table 39:</p> <p>For additional requirements, see 10.5.1.</p>	No such radiation from the equipment.	N/A

IEC 62368-1			
Clause	Requirement + Test	Result - Remark	Verdict

8	Modification to 10.5.1		
10.5.1	<p><b>Add the following after the first paragraph:</b></p> <p>For RS 1 compliance is checked by measurement under the following conditions:</p> <p>In addition to the normal operating conditions, all controls adjustable from the outside by hand, by any object such as a tool or a coin, and those internal adjustments or pre-sets which are not locked in a reliable manner, are adjusted so as to give maximum radiation whilst maintaining an intelligible picture for 1 h, at the end of which the measurement is made.</p> <p>NOTE Z1 Soldered joints and paint lockings are examples of adequate locking.</p> <p>The dose-rate is determined by means of a radiation monitor with an effective area of 10 cm<sup>2</sup>, at any point 10 cm from the outer surface of the apparatus.</p> <p>Moreover, the measurement shall be made under fault conditions causing an increase of the high voltage, provided an intelligible picture is maintained for 1 h, at the end of which the measurement is made.</p> <p>For RS1, the dose-rate shall not exceed 1 µSv/h taking account of the background level.</p> <p>NOTE Z2 These values appear in Directive 96/29/Euratom of 13 May 1996.</p>	No such radiation from the equipment.	N/A
9	Modification to G.7.1		
G.7.1	<p><b>Add the following note:</b></p> <p>NOTE Z1 The harmonized code designations corresponding to the IEC cord types are given in Annex ZD.</p>		P

IEC 62368-1			
Clause	Requirement + Test	Result - Remark	Verdict

10	Modification to Bibliography		
	<p><b>Add the following notes for the standards indicated:</b></p> <p>IEC 60130-9 NOTE Harmonized as EN 60130-9.            IEC 60269-2 NOTE Harmonized as HD 60269-2.            IEC 60309-1 NOTE Harmonized as EN 60309-1.            IEC 60364 NOTE some parts harmonized in HD 384/HD 60364 series.            IEC 60601-2-4 NOTE Harmonized as EN 60601-2-4.            IEC 60664-5 NOTE Harmonized as EN 60664-5.            IEC 61032:1997 NOTE Harmonized as EN 61032:1998 (not modified).            IEC 61508-1 NOTE Harmonized as EN 61508-1.            IEC 61558-2-1 NOTE Harmonized as EN 61558-2-1.            IEC 61558-2-4 NOTE Harmonized as EN 61558-2-4.            IEC 61558-2-6 NOTE Harmonized as EN 61558-2-6.            IEC 61643-1 NOTE Harmonized as EN 61643-1.            IEC 61643-21 NOTE Harmonized as EN 61643-21.            IEC 61643-311 NOTE Harmonized as EN 61643-311.            IEC 61643-321 NOTE Harmonized as EN 61643-321.            IEC 61643-331 NOTE Harmonized as EN 61643-331.</p>		N/A
11	ADDITION OF ANNEXES		
ZB	ANNEX ZB, SPECIAL NATIONAL CONDITIONS (EN)		P
4.1.15	<p><b>Denmark, Finland, Norway and Sweden</b></p> <p>To the end of the subclause the following is added:  <b>Class I pluggable equipment type A</b> intended for connection to other equipment or a network shall, if safety relies on connection to reliable earthing or if surge suppressors are connected between the network terminals and <b>accessible</b> parts, have a marking stating that the equipment shall be connected to an earthed <b>mains</b> socket-outlet.</p> <p>The marking text in the applicable countries shall be as follows:</p> <p>In <b>Denmark</b>: "Apparatets stikprop skal tilsluttes en stikkontakt med jord som giver forbindelse til stikproppens jord."            In <b>Finland</b>: "Laitte on liitettävä suojakoskettimilla varustettuun pistorasiaan"            In <b>Norway</b>: "Apparatet må tilkoples jordet stikkontakt"            In <b>Sweden</b>: "Apparaten skall anslutas till jordat uttag"</p>		N/A



IEC 62368-1			
Clause	Requirement + Test	Result - Remark	Verdict
<b>4.7.3</b>	<p><b>United Kingdom</b></p> <p>To the end of the subclause the following is added:</p> <p>The torque test is performed using a socket-outlet complying with BS 1363, and the plug part shall be assessed to the relevant clauses of BS 1363. Also see Annex G.4.2 of this annex</p>		P
<b>5.2.2.2</b>	<p><b>Denmark</b></p> <p>After the 2nd paragraph add the following:</p> <p>A warning (marking safeguard) for high touch current is required if the touch current exceeds the limits of 3,5 mA a.c. or 10 mA d.c.</p>	No high touch current.	N/A
<b>5.4.11.1 and Annex G</b>	<p><b>Finland and Sweden</b></p> <p>To the end of the subclause the following is added:</p> <p>For separation of the telecommunication network from earth the following is applicable:</p> <p>If this insulation is solid, including insulation forming part of a component, it shall at least consist of either</p> <ul style="list-style-type: none"> <li>• two layers of thin sheet material, each of which shall pass the electric strength test below, or</li> <li>• one layer having a distance through insulation of at least 0,4 mm, which shall pass the electric strength test below.</li> </ul> <p>If this insulation forms part of a semiconductor component (e.g. an optocoupler), there is no distance through insulation requirement for the insulation consisting of an insulating compound completely filling the casing, so that clearances and creepage distances do not exist, if the component passes the electric strength test in accordance with the compliance clause below and in addition</p> <ul style="list-style-type: none"> <li>• passes the tests and inspection criteria of 5.4.8 with an electric strength test of 1,5 kV multiplied by 1,6 (the electric strength test of 5.4.9 shall be performed using 1,5 kV),</li> </ul> <p>and</p> <ul style="list-style-type: none"> <li>• is subject to routine testing for electric strength during manufacturing, using a test voltage of 1,5 kV.</li> </ul> <p>It is permitted to bridge this insulation with a capacitor complying with EN 60384-14:2005,</p>	No TNV circuits.	N/A

IEC 62368-1			
Clause	Requirement + Test	Result - Remark	Verdict
	<p>subclass Y2.</p> <p>A capacitor classified Y3 according to EN 60384-14:2005, may bridge this insulation under the following conditions:</p> <ul style="list-style-type: none"> <li>the insulation requirements are satisfied by having a capacitor classified Y3 as defined by EN 60384-14, which in addition to the Y3 testing, is tested with an impulse test of 2,5 kV defined in 5.4.11;</li> <li>the additional testing shall be performed on all the test specimens as described in EN 60384-14;</li> </ul> <p>the impulse test of 2,5 kV is to be performed before the endurance test in EN 60384-14, in the sequence of tests as described in EN 60384-14.</p>		
5.5.2.1	<p><b>Norway</b></p> <p>After the 3rd paragraph the following is added:</p> <p>Due to the IT power system used, capacitors are required to be rated for the applicable line-to-line voltage (230 V).</p>		N/A
5.5.6	<p><b>Finland, Norway and Sweden</b></p> <p>To the end of the subclause the following is added:</p> <p>Resistors used as <b>basic safeguard</b> or bridging <b>basic insulation</b> in <b>class I pluggable equipment type A</b> shall comply with G.10.1 and the test of G.10.2.</p>	No such resistors.	N/A
5.6.1	<p><b>Denmark</b></p> <p><b>Add</b> to the end of the subclause Due to many existing installations where the socket-outlets can be protected with fuses with higher rating than the rating of the socket-outlets the protection for pluggable equipment type A shall be an integral part of the equipment. <i>Justification:</i> In Denmark an existing 13 A socket outlet can be protected by a 20 A fuse.</p>	Considered.	P
5.6.4.2.1	<p><b>Ireland and United Kingdom</b></p> <p>After the indent for <b>pluggable equipment type A</b>, the following is added: – the <b>protective current rating</b> is taken to be 13 A, this being the largest rating of fuse used in the <b>mains</b> plug.</p>		N/A

IEC 62368-1			
Clause	Requirement + Test	Result - Remark	Verdict
5.6.4.2.1	<p><b>France</b></p> <p>After the indent for <b>pluggable equipment type A</b>, the following is added: – in certain cases, the <b>protective current rating</b> of the circuit supplied from the mains is taken as 20 A instead of 16 A.</p>	Considered	P
5.6.5.1	<p>To the second paragraph the following is added:</p> <p>The range of conductor sizes of flexible cords to be accepted by terminals for equipment with a rated current over 10 A and up to and including 13 A is: 1,25 mm<sup>2</sup> to 1,5 mm<sup>2</sup> in cross-sectional area.</p>	See above.	N/A
5.6.8	<p><b>Norway</b></p> <p>To the end of the subclause the following is added: Equipment connected with an earthed mains plug is classified as <b>class I equipment</b>. See the Norway marking requirement in 4.1.15. The symbol IEC 60417-6092, as specified in F.3.6.2, is accepted.</p>	No earthed mains plug, class II equipment	N/A
5.7.6	<p><b>Denmark</b></p> <p>To the end of the subclause the following is added:</p> <p>The installation instruction shall be affixed to the equipment if the <b>protective conductor current</b> exceeds the limits of 3,5 mA a.c. or 10 mA d.c.</p>	No high protective conductor current.	N/A

IEC 62368-1			
Clause	Requirement + Test	Result - Remark	Verdict

5.7.6.2	<p><b>Denmark</b></p> <p>To the end of the subclause the following is added: The warning (marking safeguard) for high touch current is required if the touch current or the protective current exceed the limits of 3,5 mA .</p>	No exceed 3.5 mA	N/A
5.7.7.1	<p><b>Norway and Sweden</b></p> <p>To the end of the subclause the following is added: The screen of the television distribution system is normally not earthed at the entrance of the building and there is normally no equipotential bonding system within the building. Therefore the protective earthing of the building installation needs to be isolated from the screen of a cable distribution system.</p> <p>It is however accepted to provide the insulation external to the equipment by an adapter or an interconnection cable with galvanic isolator, which may be provided by a retailer, for example.</p> <p>The user manual shall then have the following or similar information in Norwegian and Swedish language respectively, depending on in what country the equipment is intended to be used in:</p> <p>“Apparatus connected to the protective earthing of the building installation through the mains connection or through other apparatus with a connection to protective earthing – and to a television distribution system using coaxial cable, may in some circumstances create a fire hazard. Connection to a television distribution system therefore has to be provided through a device providing electrical isolation below a certain frequency range (galvanic isolator, see EN 60728-11)”</p> <p>NOTE In Norway, due to regulation for CATV-installations, and in Sweden, a galvanic isolator shall provide electrical insulation below 5 MHz. The insulation shall withstand a dielectric strength of 1,5 kV r.m.s., 50 Hz or 60 Hz, for 1 min.</p> <p>Translation to Norwegian (the Swedish text will also be accepted in Norway):</p> <p>“Apparater som er koplet til beskyttelsesjord via nettplugg og/eller via annet jordtilkoplet utstyr – og er tilkoplet et koaksialbasert kabel-TV nett, kan forårsake brannfare. For å unngå dette skal det ved tilkopling av apparater til kabel-TV nett installeres en</p>	Not such system.	N/A

IEC 62368-1			
Clause	Requirement + Test	Result - Remark	Verdict
	<p>galvanisk isolator mellom apparatet og kabel-TV nettet.”</p> <p>Translation to Swedish: ”Apparater som är kopplad till skyddsjord via jordat vägguttag och/eller via annan utrustning och samtidigt är kopplad till kabel-TV nät kan i vissa fall medföra risk för brand. För att undvika detta skall vid anslutning av apparaten till kabel-TV nät galvanisk isolator finnas mellan apparaten och kabel-TV nätet.”.</p>		
<b>8.5.4.2.3</b>	<p><b>United Kingdom</b></p> <p>Add the following after the 2<sup>nd</sup> dash bullet in 3<sup>rd</sup> paragraph:</p> <p>An emergency stop system complying with the requirements of IEC 60204-1 and ISO 13850 is required where there is a risk of personal injury.</p>	No emergency stop system	N/A
<b>B.3.1 and B.4</b>	<p><b>Ireland and United Kingdom</b></p> <p>The following is applicable:</p> <p>To protect against excessive currents and short-circuits in the primary circuit of <b>direct plug-in equipment</b>, tests according to Annexes B.3.1 and B.4 shall be conducted using an external miniature circuit breaker complying with EN 60898-1, Type B, rated 32A. If the equipment does not pass these tests, suitable protective devices shall be included as an integral part of the <b>direct plug-in equipment</b>, until the requirements of Annexes B.3.1 and B.4 are met</p>	Approval current fuse used.	P

IEC 62368-1			
Clause	Requirement + Test	Result - Remark	Verdict
<b>G.4.2</b>	<p><b>Denmark</b></p> <p>To the end of the subclause the following is added:</p> <p>Supply cords of single phase appliances having a rated current not exceeding 13 A shall be provided with a plug according to DS 60884-2-D1:2011.</p> <p>CLASS I EQUIPMENT provided with socket-outlets with earth contacts or which are intended to be used in locations where protection against indirect contact is required according to the wiring rules shall be provided with a plug in accordance with standard sheet DK 2-1a or DK 2-5a.</p> <p>If a single-phase equipment having a RATED CURRENT exceeding 13 A or if a polyphase equipment is provided with a supply cord with a plug, this plug shall be in accordance with the standard sheets DK 6-1a in DS 60884-2-D1 or EN 60309-2.</p> <p>Mains socket outlets intended for providing power to Class II apparatus with a rated current of 2,5 A shall be in accordance DS 60884-2-D1:2011 standard sheet DKA 1-4a.</p> <p>Other current rating socket outlets shall be in compliance with Standard Sheet DKA 1-3a or DKA 1-1c.</p> <p>Mains socket-outlets with earth shall be in compliance with DS 60884-2-D1:2011 Standard Sheet DK 1-3a, DK 1-1c, DK1-1d, DK 1-5a or DK 1-7a</p> <p><i>Justification:</i> Heavy Current Regulations, Section 6c</p>	Direct plug in type	N/A
<b>G.4.2</b>	<p><b>United Kingdom</b></p> <p>To the end of the subclause the following is added:</p> <p>The plug part of direct plug-in equipment shall be assessed to BS 1363: Part 1, 12.1, 12.2, 12.3, 12.9, 12.11, 12.12, 12.13, 12.16, and 12.17, except that the test of 12.17 is performed at not less than 125 °C. Where the metal earth pin is replaced by an Insulated Shutter Opening Device (ISOD), the requirements of clauses 22.2 and 23 also apply.</p>	See attachment Plug test report	P

IEC 62368-1			
Clause	Requirement + Test	Result - Remark	Verdict
<b>G.7.1</b>	<p><b>United Kingdom</b></p> <p>To the first paragraph the following is added:</p> <p>Equipment which is fitted with a flexible cable or cord and is designed to be connected to a mains socket conforming to BS 1363 by means of that flexible cable or cord shall be fitted with a 'standard plug' in accordance with the Plugs and Sockets etc. (Safety) Regulations 1994, Statutory Instrument 1994 No. 1768, unless exempted by those regulations.</p> <p>NOTE "Standard plug" is defined in SI 1768:1994 and essentially means an approved plug conforming to BS 1363 or an approved conversion plug.</p>	No power cord	N/A
<b>G.7.1</b>	<p><b>Ireland</b></p> <p>To the first paragraph the following is added:</p> <p>Apparatus which is fitted with a flexible cable or cord shall be provided with a plug in accordance with Statutory Instrument 525: 1997, "13 A Plugs and Conversion Adapters for Domestic Use Regulations: 1997. S.I. 525 provides for the recognition of a standard of another Member State which is equivalent to the relevant Irish Standard</p>	No power cord	N/A
<b>G.7.2</b>	<p><b>Ireland and United Kingdom</b></p> <p>To the first paragraph the following is added:</p> <p>A power supply cord with a conductor of 1,25 mm<sup>2</sup> is allowed for equipment which is rated over 10 A and up to and including 13 A.</p>	No power cord	N/A

IEC 62368-1			
Clause	Requirement + Test	Result - Remark	Verdict
<b>ZC</b>	<b>ANNEX ZC, NATIONAL DEVIATIONS (EN)</b>		N/A
<b>10.5.2</b>	<p><b>Germany</b></p> <p>The following requirement applies:</p> <p>For the operation of any cathode ray tube intended for the display of visual images operating at an acceleration voltage exceeding 40 kV, authorization is required, or application of type approval (Bauartzulassung) and marking.</p> <p><i>Justification:</i>            German ministerial decree against ionizing radiation (Röntgenverordnung), in force since 2002-07-01, implementing the European Directive 96/29/EURATOM.</p> <p><b>NOTE</b> Contact address:            Physikalisch-Technische Bundesanstalt, Bundesallee 100, D-38116 Braunschweig,            Tel.: Int+49-531-592-6320, Internet: <a href="http://www.ptb.de">http://www.ptb.de</a></p>	Not such equipment	N/A



IEC 62368-1			
Clause	Requirement + Test	Result - Remark	Verdict

ZD	IEC and CENELEC CODE DESIGNATIONS FOR FLEXIBLE CORDS (EN)		P																																																					
	<table border="1"> <thead> <tr> <th rowspan="2">Type of flexible cord</th> <th colspan="2">Code designations</th> </tr> <tr> <th>IEC</th> <th>CENELEC</th> </tr> </thead> <tbody> <tr> <td colspan="3"><b>PVC insulated cords</b></td> </tr> <tr> <td>Flat twin tinsel cord</td> <td>60227 IEC 41</td> <td>H03VH-Y</td> </tr> <tr> <td>Light polyvinyl chloride sheathed flexible cord</td> <td>60227 IEC 52</td> <td>H03VV-F H03VVH2-F</td> </tr> <tr> <td>Ordinary polyvinyl chloride sheathed flexible cord</td> <td>60227 IEC 53</td> <td>H05VV-F H05VVH2-F</td> </tr> <tr> <td colspan="3"><b>Rubber insulated cords</b></td> </tr> <tr> <td>Braided cord</td> <td>60245 IEC 51</td> <td>H03RT-F</td> </tr> <tr> <td>Ordinary tough rubber sheathed flexible cord</td> <td>60245 IEC 53</td> <td>H05RR-F</td> </tr> <tr> <td>Ordinary polychloroprene sheathed flexible cord</td> <td>60245 IEC 57</td> <td>H05RN-F</td> </tr> <tr> <td>Heavy polychloroprene sheathed flexible cord</td> <td>60245 IEC 86</td> <td>H07RN-F</td> </tr> <tr> <td colspan="3"><b>Cords having high flexibility</b></td> </tr> <tr> <td>Rubber insulated and sheathed cord</td> <td>60245 IEC 86</td> <td>H03RR-H</td> </tr> <tr> <td>Rubber insulated, crosslinked PVC sheathed cord</td> <td>60245 IEC 87</td> <td>H03RV4-H</td> </tr> <tr> <td>Crosslinked PVC insulated and sheathed cord</td> <td>60245 IEC 88</td> <td>H03V4V4-H</td> </tr> <tr> <td colspan="3"><b>Cords insulated and sheathed with halogen-free thermoplastic compounds</b></td> </tr> <tr> <td>Light halogen-free thermoplastic insulated and sheathed flexible cords</td> <td></td> <td>H03Z1Z1-F H03Z1Z1H2-F</td> </tr> <tr> <td>Ordinary halogen-free thermoplastic insulated and sheathed flexible cords</td> <td></td> <td>H05Z1Z1-F H05Z1Z1H2-F</td> </tr> </tbody> </table>		Type of flexible cord	Code designations		IEC	CENELEC	<b>PVC insulated cords</b>			Flat twin tinsel cord	60227 IEC 41	H03VH-Y	Light polyvinyl chloride sheathed flexible cord	60227 IEC 52	H03VV-F H03VVH2-F	Ordinary polyvinyl chloride sheathed flexible cord	60227 IEC 53	H05VV-F H05VVH2-F	<b>Rubber insulated cords</b>			Braided cord	60245 IEC 51	H03RT-F	Ordinary tough rubber sheathed flexible cord	60245 IEC 53	H05RR-F	Ordinary polychloroprene sheathed flexible cord	60245 IEC 57	H05RN-F	Heavy polychloroprene sheathed flexible cord	60245 IEC 86	H07RN-F	<b>Cords having high flexibility</b>			Rubber insulated and sheathed cord	60245 IEC 86	H03RR-H	Rubber insulated, crosslinked PVC sheathed cord	60245 IEC 87	H03RV4-H	Crosslinked PVC insulated and sheathed cord	60245 IEC 88	H03V4V4-H	<b>Cords insulated and sheathed with halogen-free thermoplastic compounds</b>			Light halogen-free thermoplastic insulated and sheathed flexible cords		H03Z1Z1-F H03Z1Z1H2-F	Ordinary halogen-free thermoplastic insulated and sheathed flexible cords		H05Z1Z1-F H05Z1Z1H2-F	P
Type of flexible cord	Code designations																																																							
	IEC	CENELEC																																																						
<b>PVC insulated cords</b>																																																								
Flat twin tinsel cord	60227 IEC 41	H03VH-Y																																																						
Light polyvinyl chloride sheathed flexible cord	60227 IEC 52	H03VV-F H03VVH2-F																																																						
Ordinary polyvinyl chloride sheathed flexible cord	60227 IEC 53	H05VV-F H05VVH2-F																																																						
<b>Rubber insulated cords</b>																																																								
Braided cord	60245 IEC 51	H03RT-F																																																						
Ordinary tough rubber sheathed flexible cord	60245 IEC 53	H05RR-F																																																						
Ordinary polychloroprene sheathed flexible cord	60245 IEC 57	H05RN-F																																																						
Heavy polychloroprene sheathed flexible cord	60245 IEC 86	H07RN-F																																																						
<b>Cords having high flexibility</b>																																																								
Rubber insulated and sheathed cord	60245 IEC 86	H03RR-H																																																						
Rubber insulated, crosslinked PVC sheathed cord	60245 IEC 87	H03RV4-H																																																						
Crosslinked PVC insulated and sheathed cord	60245 IEC 88	H03V4V4-H																																																						
<b>Cords insulated and sheathed with halogen-free thermoplastic compounds</b>																																																								
Light halogen-free thermoplastic insulated and sheathed flexible cords		H03Z1Z1-F H03Z1Z1H2-F																																																						
Ordinary halogen-free thermoplastic insulated and sheathed flexible cords		H05Z1Z1-F H05Z1Z1H2-F																																																						

IEC62368_1E ATTACHMENT			
Clause	Requirement + Test	Result - Remark	Verdict

**ATTACHMENT TO TEST REPORT**  
**IEC 62368-1**  
**U.S.A. AND CANADA NATIONAL DIFFERENCES**  
(Audio/video, information and communication technology equipment – Part 1: Safety requirements)

**Differences according to..... :** CSA/UL 62368-1:2019

**TRF template used:..... :** IECEE OD-2020-F3, Ed. 1.1

**Attachment Form No. .... :** US\_CA\_ND\_IEC62368\_1E

**Attachment Originator..... :** UL(US)

**Master Attachment..... :** Dated 2021-02-04

**Copyright © 2021 IEC System for Conformity Testing and Certification of Electrical Equipment (IECEE), Geneva, Switzerland. All rights reserved.**

**IEC 62368-1 - US and Canadian National Differences**  
**Special National Conditions based on Regulations and Other National Differences**

1 (1DV.1) (1.3)	All equipment is to be designed to allow installation in accordance with the National Electrical Code (NEC), ANSI/NFPA 70, the Canadian Electrical Code (CEC), Part 1, CAN/CSA C22.1, and when applicable, the National Electrical Safety Code, IEEE C2. Also, for such equipment marked or otherwise identified, installation is allowed per the Standard for the Protection of Information Technology Equipment, ANSI/NFPA 75.	In accordance with the National Electrical Code (NEC) and the Canadian Electrical Code (CEC) part 1 CAN/CSA C22.1, ANSI/NFPA 70, and unless marked or otherwise identified, the Standard for Electronic Computer/Data-Processing Equipment, ANSI/NFPA 75.	P
1 (1DV.2.1)	This standard includes additional requirements for equipment used for entertainment purposes intended for installation in general patient care areas of health care facilities. See Annex DVB.	Added.	N/A
1 (1DV.2.2)	This standard includes additional requirements for equipment intended for mounting under cabinets. See Annex DVC.		N/A
1 (1DV.2.3)	IEC 62368-3 clause 5 for DC power transfer at ES1 or ES2 voltage levels is considered informative. IEC 62368-3 clause 6 for remote power feeding telecommunication (RFT) circuits is considered normative (see ITU K.50). Alternatively, equipment with RFT circuits are given in either UL 2391 or CSA/UL 60950-21. RFT-C circuits are not permitted unless the RFT-C circuit complies with RFT-V limits ( $\leq 200V$ per conductor to earth).		P

IEC62368_1E ATTACHMENT			
Clause	Requirement + Test	Result - Remark	Verdict
1 (1DV.3)	For protection against direct lightning strikes, reference is made to NFPA 780 and CAN/CSA-B72 for additional requirements.	Not such equipment	N/A
1 (DV.5)	Additional requirements apply to some forms of power distribution equipment, including sub-assemblies.		N/A
4.1 (4.1.17)	For lengths exceeding 3.05 m, external interconnecting cable assemblies are required to be a suitable cable type (e.g., DP, CL2) specified in the NEC.	No such construction	N/A
	For lengths 3.05 m or less, external interconnecting cable assemblies that are not types specified in the NEC generally are required to have special construction features and identification markings.		N/A
4.6 (4.6.2)	Wire-wrap terminals have special construction and performance requirements.		N/A
4.8 (4.8.3, 4.8.4.5, 4.8.5)	Coin / button cell batteries have modified special construction and performance requirements.		N/A
5.4.2.3.2 (5.4.2.3.2.1)	Surge Arrestors and Transient Voltage Surge Suppressors installed external to the equipment are required to comply with the appropriate NEC and CEC requirements.		N/A
5.5.9	Receptacles, rated 125-V, single phase, 15- or 20-A accessible to either ordinary, instructed, or skilled persons are required to be provided with GFCI Protection for Personnel if the equipment containing the receptacles is installed outdoors. The protection devices are required to comply with UL 943, and CAN/CSA C22.2 No.144.		N/A
5.6.3	Protective earthing conductors comply with the minimum conductor sizes in Table G.7, except as required by Table G.7ADV.1 for cord connected equipment, or Annex DVH for permanently connected equipment.		N/A
5.7.8 (5.7.8.1)	Equipment intended to receive telecommunication ringing signals is required to comply with a special touch current measurement tests.		N/A
6.5.1	PS3 wiring outside a fire enclosure is required to comply with single fault testing in B.4, or be current limited per one of the permitted methods.		N/A

IEC62368_1E ATTACHMENT			
Clause	Requirement + Test	Result - Remark	Verdict
Annex F (F.3.3.9)	Output terminals provided for supply of other equipment, except mains supply, are required to be marked with a maximum rating or reference to equipment permitted to be connected.		N/A
Annex F (F.3.7)	Outdoor Enclosures are required to be classified and marked in accordance with UL 50 or 50E, or CAN/CSA C22.2 No. 94.1 or 94.2.		N/A
Annex G (G.7)	Permanent connection of equipment to the mains supply by a power supply cord is not permitted, except for certain equipment, such as ATMs.		N/A
	Power supply cords are required to have attachment plugs rated not less than 125 percent of the rated current of the equipment.		N/A
	Flexible power supply cords are required to be compatible with Article 400 of the NEC, and Tables 11 and 12 of the CEC.		N/A
	Minimum cord length is required to be 1.5 m, with certain constructions such as external power supplies allowed to consider both input and output cord lengths into the requirement. Power supply cords are required to be no longer than 4.5 m in length if used in ITE Rooms.		N/A
	Power supply cords for outdoor equipment are required to be suitable outdoor use type as required by Section 400.4 of the NEC and Rule 4-012 of the CEC, i.e., marked "W."		N/A
Annex H.2	Continuous ringing signals under normal operating conditions up to 16 mA only are permitted if the equipment is subjected to special installation and performance restrictions.		N/A
Annex H.4	For circuits with other than ringing signals and with voltages exceeding 42.4 V <sub>peak</sub> or 60 V <sub>d.c.</sub> , the maximum acceptable current through a 2000 ohm resistor (or greater) connected across the voltage source with other loads disconnected is 7.1 mA peak or 30 mA d.c. under normal operating conditions.		N/A
Annex Q (Q.3)	Equipment with paired conductor and/or coax communications cables/wiring connected to building wiring are required to have special voltage, current, power and marking requirements.		N/A

IEC62368_1E ATTACHMENT			
Clause	Requirement + Test	Result - Remark	Verdict
Annex DVA (1)	Equipment that is designed such that it may be powered from a separate electrical service, is required to meet applicable requirements for service equipment for control and protection of services and their installation and complies with Article 230 of the National Electrical Code (NEC), NFPA 70 and Section 6 of the Canadian Electrical Code, Part I, CSA C22.1.		N/A
	Equipment intended for use in spaces used for environmental air (plenums) are subjected to special flammability requirements for heat and visible smoke release.		N/A
	For ITE room applications, automated information storage systems with combustible media greater than 0.76 m <sup>3</sup> (27 cu ft) are required to have a provision for connection of either automatic sprinklers or a gaseous agent extinguishing system with an extended discharge.		N/A
	Consumer products designed or intended primarily for children 12 years of age or younger are subject to additional requirements in accordance with U.S. and Canadian Regulations.		N/A
	Baby monitors are required to additionally comply with ASTM F2951, Consumer Safety Specification for Baby Monitors.		N/A
	Storage batteries and battery management equipment, other than associated with lead-acid batteries, and including battery backup systems that are not an integral part of stationary AV and ICT equipment, such as provided in separate cabinets, are required to be certified (listed) to the appropriate standard(s) for such storage batteries and equipment.		N/A
Annex DVA (5.6)	For Pluggable Equipment Type A, the protection in the installation is assumed to be 20A.	Considered	P
Annex DVA (6.3)	The maximum quantity of flammable liquid stored in equipment is required to comply with NFPA 30.		N/A

IEC62368_1E ATTACHMENT			
Clause	Requirement + Test	Result - Remark	Verdict
Annex DVA (6.4.8)	For ITE room applications, enclosures with combustible material measuring greater than 0.9 m <sup>2</sup> (10 sq ft) or a single dimension greater than 1.8 m (6 ft) are required to have a flame spread rating of 50 or less. For equipment with the same dimensions for other applications, an external surface that is not a fire enclosure requires a minimum flammability classification of V-1.		N/A
Annex DVA (10.3)	Equipment with lasers is required to meet the U.S. Code of Federal Regulations 21 CFR 1040 (and the Canadian Radiation Emitting Devices Act, REDR C1370).		N/A
Annex DVA (10.5)	Equipment that produces ionizing radiation is required to comply with the U.S. Code of Federal Regulations, 21 CFR 1020 (and the Canadian Radiation Emitting Devices Act, REDR C1370).		N/A
Annex DVA (F.3.3.4)	Equipment for use on a.c. mains supply systems with a neutral and more than one phase conductor (e.g. 120/240 V, 3-wire) require a special marking format for electrical ratings. Additional considerations apply for voltage ratings that exceed the attachment cap rating or that are lower than the "Normal Operating Condition" in Table 2 of CAN/CSA C22.2 No. 235."	Shall be evaluated during national approval.	N/A
Annex DVA (F.3.3.6)	Equipment identified for ITE (computer) room installation is required to be marked with the rated current.		N/A
Annex DVA (G.1)	Vertically-mounted disconnect switches and circuit breakers are required to have the "on" position indicated by the handle in the up position.		N/A
Annex DVA (G.3.4)	Suitable NEC/CEC branch circuit protection rated at the maximum circuit rating is required for all standard supply outlets and receptacles (such as supplied in power distribution units) if the supply branch circuit protection is not suitable.		N/A
	Where a fuse is used to provide Class 2 or Class 3 current limiting, it is not operator-accessible unless it is non-interchangeable.		N/A
Annex DVA (G.4.2)	Equipment with isolated ground (earthing) receptacles is required to comply with NEC 250.146(D) and CEC 10-400 and 10-612.		N/A

IEC62368_1E ATTACHMENT			
Clause	Requirement + Test	Result - Remark	Verdict
Annex DVA (G.4.3)	Interconnection of units by conductors supplied by a limited power source, or a Class 2 circuit defined in the NEC/CEC may have field wiring connections other than specified in DVH.3, such as wire-wrap and crimp-on types, if the limited power source and Class 2 circuits are separated from all other circuits by barriers, routing or fixing.		N/A
Annex DVA (G.5.3)	Power distribution transformers distributing power at 100 volts or more, and rated 10 kVA or more, require special transformer overcurrent protection.		N/A
Annex DVA (G.5.4)	Motor control devices are required for cord-connected equipment with a mains-connected motor if the equipment is rated more than 12 A, or if the equipment has a nominal voltage rating greater than 120 V, or if the motor is rated more than 1/3 hp (locked rotor current over 43 A).		N/A
Annex DVA (G.7)	Flexible cords used outdoors are required to have the suffix "W" marked on the flexible cord.		N/A
Annex DVA (M)	For ITE room applications, equipment with battery systems capable of supplying 750 VA for five minutes are required to have a battery disconnect means that may be connected to the ITE room remote power-off circuit.		N/A
Annex DVA (Q)	If applicable per NEC 725.121(C), some limited power sources supplied from AV/ICT equipment are required to have a label indicating the maximum voltage and maximum current, or maximum voltage and nominal current output for each connection point. Where multiple connection points have the same rating, a single label is permitted to be used.		N/A
	Wiring terminals intended to supply Class 2 outputs in accordance with the NEC or CEC Part 1 are required to be marked with the voltage rating and "Class 2" or equivalent. The marking is located adjacent to the terminals and visible during wiring.		N/A
	Applicable parts of Chapter 8 of the NEC, and Rules 54 and 60 of the CEC, may be applicable to ITE installed outdoors with connections to communication systems.		N/A

IEC62368_1E ATTACHMENT			
Clause	Requirement + Test	Result - Remark	Verdict
Annex DVB (1)	Additional requirements apply for equipment used for entertainment purposes intended for installation in general patient care areas of health care facilities.		N/A
Annex DVC (1)	Additional requirements apply for equipment intended for mounting under kitchen cabinets.		N/A
Annex DVE (4.1.1)	Some equipment, components, sub-assemblies and materials associated with the risk of fire, electric shock, or personal injury are required to have component or material ratings in accordance with the applicable national (U.S. and Canadian) component or material requirements. These equipment and components include: appliance couplers, attachment plugs, battery backup systems, circuit breakers, communication circuit accessories, connectors (used for current interruption of non-LPS circuits), direct plug-in equipment, electrochemical capacitor modules (energy storage modules with ultracapacitors), enclosures (outdoor), flexible cords and cables, fuses (branch circuit), ground-fault current interrupters, interconnecting cables, modular data centers, power supply cords, some power distribution equipment, printed wiring, protectors for communications circuits, receptacles, surge protective devices, vehicle battery adapters, wire connectors, and wire and cables.		N/A
Annex DVH	Equipment for permanent connection to the mains supply is subjected to additional requirements.		N/A
Annex DVH (DVH.1)	Wiring methods (terminals, leads, etc.) used for the connection of the equipment to the mains are required to be in accordance with the NEC/CEC.		N/A
Annex DVH (DVH.3.2)	Terminals for permanent wiring, including protective earthing terminals, are required to be suitable for U.S./Canadian wire gauge sizes, rated 125 percent of the equipment rating, and be specially marked when specified.		N/A
	Wire binding screws are not permitted to attach conductors larger than 10 AWG (5.3 mm <sup>2</sup> ).		N/A
Annex DVH (DVH.4)	Permanently connected equipment is required to have a suitable wiring compartment and wire bending space.		N/A



IEC62368_1E ATTACHMENT			
Clause	Requirement + Test	Result - Remark	Verdict
Annex DVH (DVH 5.5)	Equipment connected to a centralized d.c. power system, and having one pole of the DC mains input terminal connected to the main protective earthing terminal in the equipment, is required to comply with special earthing, wiring, marking and installation instruction requirements.		N/A
Annex DVI (6.7)	Equipment intended for connection to telecommunication network outside plant cable is required to be protected against overvoltage from power line crosses.		N/A
Annex DVJ (10.6.1)	Equipment connected to a telecommunication and cable distribution networks and supplied with an earphone intended to be held against, or in the ear is required to comply with special acoustic pressure requirements.		N/A

IEC62368_1E ATTACHMENT			
Clause	Requirement + Test	Result - Remark	Verdict

<b>ATTACHMENT TO TEST REPORT</b> <b>IEC 62368-1</b> <b>SINGAPORE NATIONAL DIFFERENCES</b> Audio/video, information and communication technology equipment - Part 1: Safety requirements			
<b>Differences according to</b> ..... : Special National Conditions			
<b>TRF template used</b> :..... : IECEE OD-2020-F3, Ed. 1.1			
<b>Attachment Form No.</b> .... : SG_ND_IEC62368_1E			
<b>Attachment Originator</b> ..... : Intertek Testing Services (Singapore) Pte Ltd			
<b>Master Attachment</b> ..... : 2022-07-08			
<b>Copyright © 2022 IEC System for Conformity Testing and Certification of Electrical Equipment (IECEE), Geneva, Switzerland. All rights reserved.</b>			
	<b>National Differences</b>		
	Not Applicable		N/A
Chapter 4.2	<b>Special national conditions (if any)</b> Controlled goods under the Consumer Protection (Safety Requirements) Registration Scheme (CPS) are required to be tested to additional requirements stipulated by the Consumer Product Safety Office (CPSO) of Enterprise Singapore in Chapter 7 of the CPS information booklet.  The CPS information booklet is updated on an ongoing basis. At the point of testing, refer to the latest copy of the CPS information booklet for the minimum edition of standard to apply for testing of products under the CPS scheme and any new requirements.  Link to CPS information booklet: <a href="https://www.consumerproductsafety.gov.sg/files/cps-info-booklet.pdf">https://www.consumerproductsafety.gov.sg/files/cps-info-booklet.pdf</a>		N/A
<u>Clause</u> 1	All appliances must be tested to 230 VAC, 50 Hz.		P
4	Appliance fitted with voltage selector shall be tested as follows: Connect appliance to 230 VAC mains with voltage selector switch to settings not suitable for operation at 230 VAC.		N/A
5	All appliances (with tropical test requirements in applicable Standards) shall comply with the tropical condition test as stated in the relevant IEC Standards.		P

IEC62368_1E ATTACHMENT			
Clause	Requirement + Test	Result - Remark	Verdict
7	All Class I appliances must be fitted with 3-pin mains plugs that are registered with the CPSO.		N/A
8	a) All Class II appliances must be fitted with 2-pin mains plug complying with EN 50075. b) Class II appliances that are fitted with 3-pin mains plugs must use plugs that are registered with the CPSO.		N/A
9	Detachable power cord set must be listed in the test report critical component list.		N/A
14	AC Adaptor incorporated with 13A socket-outlet to be tested to additional tests clauses 13, 17 and 18 of SS 145 Part 3: 2020.		N/A
15	Supplier who is supplying AC adaptors with detachable interchangeable plug pins must include with its products, written instructions to inform customer on the type of detachable interchangeable plug pins that are approved and suitable to use in Singapore. These instructions are to be submitted to the Conformity Assessment Body for verification when applying for Certificate of Conformity.		N/A
16	For AC Adaptors supplied together with Personal Mobility Devices: <ol style="list-style-type: none"> <li>1. Registered Supplier to declare the model of the AC adaptor that is to be used with/ bundled together with the PMDs;</li> <li>2. Registered Supplier to provide valid IEC 60950-1 or IEC 62368-1 test reports for certification and registration of the declared AC adaptor under the CPS scheme; and</li> <li>3. Registered Supplier to provide the UL 2272 test report as supporting document, showing that the listed AC adaptor in the UL 2272 test report is the model declared to be used with/ bundled together with the PMDs.</li> </ol>		N/A
18	CD/ DVD ROMs (used in personal computers) to have test certificate showing that CD/DVD ROM drive has complied with IEC 60825- 1.		N/A
19	Modem card incorporated in the personal computer must be tested at set level (sub-clauses 5.1 & 6 of IEC 60950) or at component level.		N/A
20	Powerline Ethernet Adaptor incorporated with 13A socket-outlet, to be tested to additional test clauses 13, 17 & 18 of SS 145 Part 3: 2020.		N/A
	Other additional requirements which may be included in Chapter 7 of the information booklet in ongoing basis at the time of testing.		N/A

## EN 50075: 1990 (Partial)

Clause	Requirement – Test	Result - Remark	Verdict
--------	--------------------	-----------------	---------

**European plug portion test for EU plug portion (MODEL: MC-68-EU)**

6	<b>Marking</b>		<b>P</b>
	Appliances shall be marked as follows:	Incorporated with adaptor.	<b>P</b>
	Rated current in amperes (A)		<b>P</b>
	Rated Voltage in volts (V)		<b>P</b>
	Symbol for nature of supply (~)		<b>P</b>
	Name, trade mark or identification mark of manufacturer or responsible vendor		<b>P</b>
	Type reference		<b>P</b>

7	<b>Dimensions</b>		<b>P</b>	
	Plug shall comply with Standard Sheet 1		<b>P</b>	
	Between two pins (pin base)	18.0 – 19.2 mm	18.27 mm	<b>P</b>
	Between two pins (pin top)	17.0 – 18.0 mm	17.68 mm	<b>P</b>
	Diameter of pin (metallic part)	4 <sup>±0.06</sup> mm	4.00 mm	<b>P</b>
	Diameter of pin (pin base)	max. 4.0 mm	3.99 mm	<b>P</b>
	Distance from the engagement face of the plug <sup>3)</sup>	max. 4.0 mm	3.81 mm	<b>P</b>
	Diameter of pin (middle part)	max. 3.8 mm	3.70 mm	<b>P</b>
	Pin length	19 <sup>±0.5</sup> mm	19.10 mm	<b>P</b>
	Length of pin except metal part	10 <sup>+1.0</sup> mm	10.52 mm	<b>P</b>
	Shape of pin top		Round shape	<b>P</b>
	Length of plug base	35.3 <sup>±0.7</sup> mm	35.56 mm	<b>P</b>
	Width of plug base	13.7 <sup>±0.7</sup> mm	14.27 mm	<b>P</b>
	Diagonal dimension of plug base within a distance of 18mm	26.1 <sup>±0.5</sup> mm 26.1 <sup>±0.5</sup> mm	26.13 mm 26.30 mm	<b>P</b>
	Angle	45°	45 °	<b>P</b>
	Radius	R 5 -0, +1 mm	R5.70 mm	<b>P</b>

8	<b>Protection against electric shock</b>		<b>P</b>
8.1	Live parts of the plug not accessible (standard test finger)	Incorporated with adaptor.	<b>P</b>
8.2	No connection between one plug-pin and socket outlet		<b>P</b>
8.3	External parts of insulating material		<b>P</b>

9	<b>Construction</b>	<b>P</b>
---	---------------------	----------

EN 50075: 1990 (Partial)			
Clause	Requirement – Test	Result - Remark	Verdict
9.1	Plugs are not replaceable	Incorporated with adaptor.	P
9.2	Switches, fuse, lampholder not incorporated		P
9.3	Solid pins	See clause 13	P
	Adequate mechanical strength		P
9.4	Pins locked against rotation	See clause 13.1 & 13.4	P
	Adequate fixed into the body		P
9.5	Kind of connection		P
9.6	Easily to be withdrawn from socket-outlet	Incorporated with adaptor	P
<b>10</b>	<b>Resistance to humidity</b>		<b>P</b>
	-Humidity treatment for 48 hours	Tested with adaptor.	P
<b>11</b>	<b>Insulation resistance and electric strength</b>		<b>P</b>
11.1	Insulation resistance (500V, min 5M $\Omega$ )	200M $\Omega$	P
11.2	Electric strength (2000V)	(see appended table)	P
<b>13</b>	<b>Mechanical strength</b>		<b>P</b>
13.1	Pressed with 150N for 5 min		P
13.2	Tumbling barrel according to EN 61558-1 Number of cycles:	Adaptor mass: 84g Number of cycles:50 falls (All pin holder and enclosure sources are tested)	P
	No damages after the test		P
	Requirements of clause 7 and 8.2 still fulfilled		N/A
13.3	Rubbing test of plug-pins: 10000 cycles, 4N		P
	No damage of the pins		P
13.4	Pull test at 70°C with 40N		P
	Pins not more than 1 mm displaced	Displacement: 0.2 mm	P
<b>14</b>	<b>Resistance to heat and to aging</b>		<b>P</b>
14.1	Sufficient resistant to heat	Incorporated with adaptor.	P
14.1.1	After 1 h in heating cabinet at 100°C no damage shown	Tested with adaptor. (All pin holder sources are tested)	P
14.1.2	After 1 h in heating cabinet at 80°C and a force of 20N through the jaws no damage shown		P
14.2	Aging test		P
	-at 70°C for 168h		P
	-at room temperature for 96h		P

## EN 50075: 1990 (Partial)

Clause	Requirement – Test	Result - Remark	Verdict
--------	--------------------	-----------------	---------

	No traces of cloth at a force of 5N		P
	No damage leads to non-compliance		P

15	Current-carrying parts and connections resistance to heat and to aging		P
15.1	Connections withstand the mechanical stresses occurring in normal use		P
15.2	Contact pressure not through isolating material		P
15.3	Current carrying parts of copper		P
	No electroplated coating when part is subjected to mechanical wear		P
	Other metals having a mechanical strength, an electrical conductivity and a resistance to corrosion		N/A

16	Creepage distances, clearances and distances through insulation		P
	Live parts of different polarity: 3mm	5.0mm	P
	Through insulation between live parts and accessible surfaces: 1.5mm	2.0mm	P

17	Resistance of insulation material to abnormal heat and fire		P
	Insulating material not unduly affected by abnormal heat and by fire	(see appended table)	P

EN 50075: 1990 (Partial)

Clause	Requirement – Test	Result - Remark	Verdict
--------	--------------------	-----------------	---------

11.1	TABLE: Insulation resistance measurements		P
Measured between:		Result	
Pins connected together and the body ( $\geq 5M\Omega$ )		200M $\Omega$	P
Each pins in turn and the other, the latter being connected to the body ( $\geq 5M\Omega$ )		200M $\Omega$	P
Note: --			

11.2	TABLE: electric strength measurements		P
Test voltage applied between:		Test voltage (V)	Break down
Pins connected together and the body		2000VAC	No
Each pins in turn and the other, the latter being connected to the body		2000VAC	No
Note: --			

17.3	TABLE: Resistance of insulating material to abnormal heat and to fire		P
Parts that retain current-carrying parts in position: 750°C			P
Other parts: 650°C			P
Note: All pin holder and enclosure sources are tested.			

EN 50075: 1990 (Partial)			
Clause	Requirement – Test	Result - Remark	Verdict

### Standard sheet 1

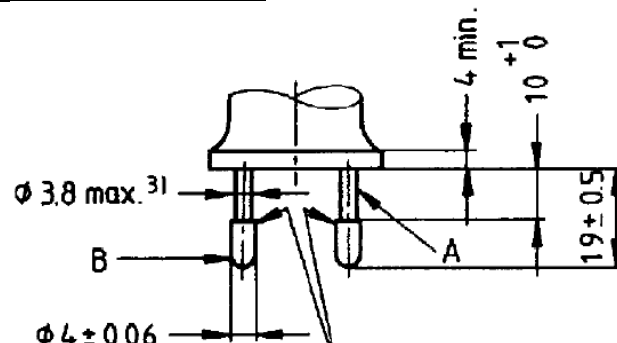
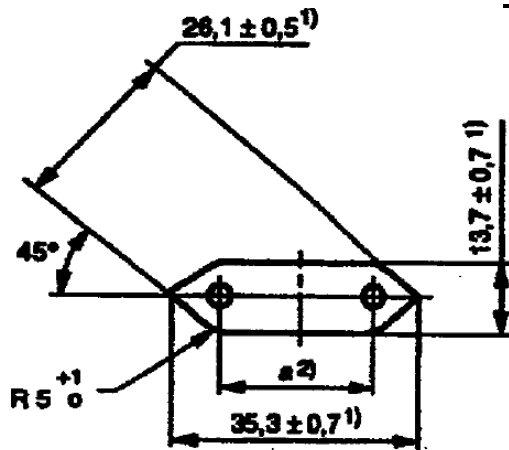

The edges of the metal parts shall be either chamfered or rounded off

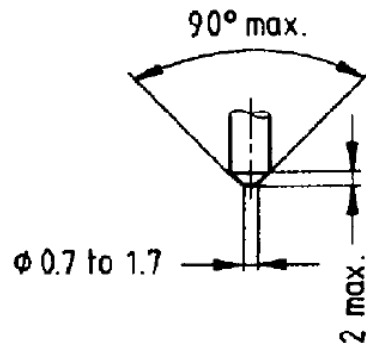

Alternative for end of pins

Dimensions in millimetres

A = insulating collar

B = metal pin

<sup>1)</sup> These dimensions shall not be exceeded within a distance of 18 mm from the engagement face of the plug.

<sup>2)</sup> Dimension  $a$  is:

18 mm to 19,2 mm in the plane of the engagement face;

17 mm to 18 mm at the ends of the pins.

<sup>3)</sup> This dimension may be increased to 4 mm within a distance of 4 mm from the engagement face of the plug.

Pin ends shall be rounded, or conical as shown in detail sketch.

The sketches are not intended to govern design except as regards the dimensions shown.



BS 1363-1: 2016+A1:2018 (Partial)			
Clause	Requirement – Test	Result - Remark	Verdict

British plug portion: (MODEL: MC-68-UK)			
12	Construction of Plugs		P
12.1	The disposition of the pins shall be shown as figure 4.	The dispositions of the pins were shown as figure 4.	P
12.2	Pin and sleeve dimensions, body outline were checked according to figure 4 of BS1363: Part 1.	9.30 mm was measured from the engagement surface. (It shall not less than 6.35 mm)	P
		The dimensions were found within the specified limits as shown in figure 4. (please refer to attached appendix 1 for details)	P
	The plug portion shall enter the gauge fully with a force less than 10N was applied to the centre of the sample at right angle	Sample could enter into the gauge fully with a force less than 10 N.	P
12.3	No parts of a line or neutral pin shall be less than 9.5mm from the periphery of the plug measured along the engagement surface.	Complied.	P
12.9	Plug pins were constructed of brass or nickel plated brass	Brass.	P
12.9.1	Exposed surface of plug pins were smooth and free from burrs or sharp edges and other irregularities, which could cause damage or excessive wear to sockets or shutters.	Complied.	P
12.9.4	The adaptor plug pins were tested as specified in the standard.	After test at 1100 N, the pin portions couldfit the relevant gauge.	P
12.9.5	Plugs with nickel plated brass shall not cause excessive wear to socket contacts or shutters of socket-outlets.	See below	P
	Each plug is inserted into and withdrawn from the socket-outlet at a rate of six insertions and six withdrawals per minute, the speed of travel of the plug being approximately 150 mm/s. The periods during which the plug is inserted and withdrawn shall be approximately equal. The plug pins are renewed or a new plug is used after each 5 000 insertions and withdrawals.	The socket-outlet show no sign of damage that would impair further use. The plugs show no damage and conform to the dimensional requirements of 12.2. The shutters of the socket-outlet operate satisfactorily and the socket contacts shall be safely shielded.	P
12.9.6	Each pin of the adapter was subjected to a torque of 1Nm for 60s as specified in the standard.	After the test, the pin portion couldfit the relevant gauge.	P
12.11	The adaptors were tested as specified in standard. After being placed in an oven at 70°C for 1 hour, each pin of the samples was subjected for 60s to a pull of 100N in the oven.	After the test, no plug pin was detached and the plug pins couldfit the relevant gauge.	P

## BS 1363-1: 2016+A1:2018 (Partial)

Clause	Requirement – Test	Result - Remark	Verdict
12.12	The degree of the flexibility of mounting of the plug pins was checked by inspection	Complied.	P
12.13	Suitable means shall be provided for withdrawing the plug without subjecting the flexible cord to stress.	Complied.	P
12.16	Line and neutral plug pin shall be fitted with insulating sleeves. The dimensions of the pin and sleeve shall fall within the specific limit.	Both line and neutral pins were fitted with insulating sleeve.	P
12.17.1	Plug pin sleeve shall be compliance with 12.17.2 to 12.17.4	Complied.	P
12.17.2	Electric strength test applied between the metal part of the plug pin and the sleeve. (1250V±30V for 60s)		P
12.17.3	Abrasion test for plug pin sleeve The plug pin sleeves were subjected to 20000 movements of abrasion as specified in the standard.	After the test, the sleeves showed no damage that impaired further use and could satisfy the electric strength test in 12.17.2	P
12.17.4	Resistance to deformation The plug pins with sleeves were placed in a heating cabinet at 200°C and tested according to the standard for 120min. The test shall be carried out at 125°C based on the UK deviation to clause 4.3.6 for Direct plug-in equipment in IEC 62368-1:2018	After the test carried out at 125 °C for 120 min, only slightly impression observed, the impressions were less than 50 % of the thickness measured before the test.	P
22.2	Parts of insulating material shall be sufficiently resistant to heat and still shaving its location and function.	Complied. See 22.2.1	P
22.2.1	Compliance checked as follows: a) Parts of ceramic material are used; b) external parts of plugs tested according to 22.1.3; c) all other parts of insulating material including ISOD subjected to the ball pressure at a temperature of 75°C ± 5°C	See appended table 22.2.1	P
23	Resistance to abnormal heat, fire and tracking		P
23.1	Plugs shall be proof against abnormal heat, fire and tracking		P
23.1.1	Compliance shall be checked by the test described in 23.2		P
23.2	Glow-wire test The test is performed according to BS EN 60695-2-11:2014 and at the test temperature given in Table 10 a) Parts necessary to retain live parts in position including ISOD were tested at 750°C. Parts not necessary to retain live in position were tested at 650°C.	See appended table 23.2	P

BS 1363-1: 2016+A1:2018 (Partial)			
Clause	Requirement – Test	Result - Remark	Verdict

Additional Requirements (Clause 12.2, 12.9.4.3, 12.9.5, 12.9.6, 22.2 and 23) for the ISOD According to the standard BS 1363-1			
12.2	Solid insulated shutter opening device should comply all the dimensions specified in Figure 4 with exception of the width of the ISOD should be 4.05 mm maximum and 3.90 mm minimum. and its height which should be 8.05 mm maximum and 7.75 mm minimum	The measured dimensions were found to be within the specified limits. (see attached appendix 1 for details)	P
12.9.4	Solid insulated shutter opening device were tested as specified in the standard.	After subjected to a force of 400N, the pin portion still could fit the relevant gauge.	P
12.9.5	Plugs with ISOD shall not cause excessive wear to socket contacts or shutters of socket-outlets.	See below	P
	Each plug is inserted into and withdrawn from the socket-outlet at a rate of six insertions and six withdrawals per minute, the speed of travel of the plug being approximately 150 mm/s. The periods during which the plug is inserted and withdrawn shall be approximately equal. The plug pins are renewed or a new plug is used after each 5 000 insertions and withdrawals.	The socket-outlet show no sign of damage that would impair further use.  The plugs show no damage and conform to the dimensional requirements of 12.2.  The shutters of the socket-outlet operate satisfactorily and the socket contacts shall be safely shielded.	P
12.9.6	ISOD of the adapter was subjected to a torque of 1Nm for 60s as specified in the standard.	After the test, the pin portion could fit the relevant gauge.	P

22.2.1	TABLE: Ball-pressure test						
Specimen				Ball-pressure test			
Part	Material	Material-thickness [mm]	Colour	[C°]	Measured [mm]	Required [mm]	Result
Plug portion (including ISOD)	LOTTE CHEMICAL CORPORATION / HN-1064(+)	1.5mm*2	Black	75	0.9	< 2.0	Pass
Plug portion (including ISOD)	SABIC INNOVATIVE PLASTICS US L L C / 945 (GG)	1.5mm*2	black	75	0.9	< 2.0	Pass
Plug portion (including ISOD)	SABIC JAPAN L L C / 945 (GG)	1.5mm*2	black	75	1.0	< 2.0	Pass
Plug portion (including ISOD)	COVESTRO DEUTSCHLAND AG [PC RESINS] / FR6005	1.5mm*2	black	75	1.0	< 2.0	Pass

## BS 1363-1: 2016+A1:2018 (Partial)

Clause	Requirement – Test	Result - Remark	Verdict
--------	--------------------	-----------------	---------

Plug portion (including ISOD)	DONGGUAN HUAZHE METALS & PLASTICS LTD / HZ-88	1.5mm*2 black 75	1.0	< 2.0	Pass
-------------------------------	-----------------------------------------------	------------------	-----	-------	------

Supplementary information:

23.2	TABLE: Glow-wire-test [60 s]								
Specimen				Flame					
Part	Material	Material-thickness [mm]	Colour	[°C]	Start [s]	End [s]	Height [mm]	Ignition of tissue paper	Result
Enclosure/ Plug portion (including ISOD)	LOTTE CHEMICAL CORPORATION / HN-1064(+)	1.5mm*2	black	750	--	--	--	No	Pass
Enclosure/ Plug portion (including ISOD)	SABIC INNOVATIVE PLASTICS US L L C / 945 (GG)	1.5mm*2	black	750	--	--	--	No	Pass
Enclosure/ Plug portion (including ISOD)	SABIC JAPAN L L C / 945 (GG)	1.5mm*2	black	750	--	--	--	No	Pass
Enclosure/ Plug portion (including ISOD)	COVESTRO DEUTSCHLAND AG [PC RESINS] / FR6005	1.5mm*2	black	750	--	--	--	No	Pass
Enclosure/ Plug portion (including ISOD)	DONGGUAN HUAZHE METALS & PLASTICS LTD / HZ-88	1.5mm*2	black	750	--	--	--	No	Pass

Supplementary information:

BS 1363-1: 2016+A1:2018 (Partial)

Clause	Requirement – Test	Result - Remark	Verdict
--------	--------------------	-----------------	---------

UK plug portion for switching power adapter

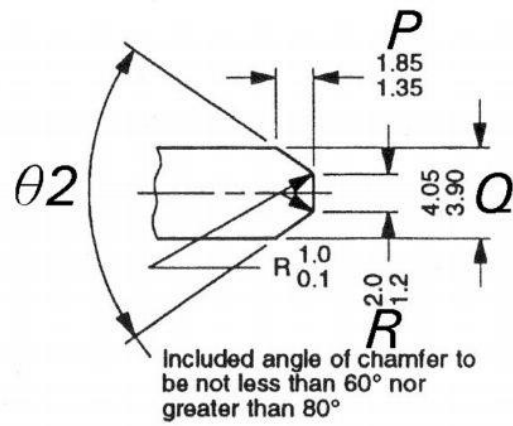
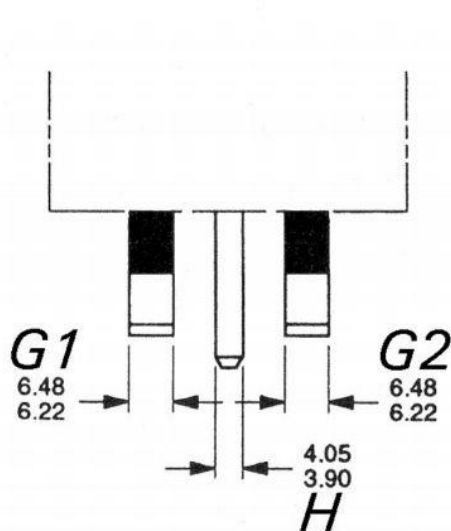
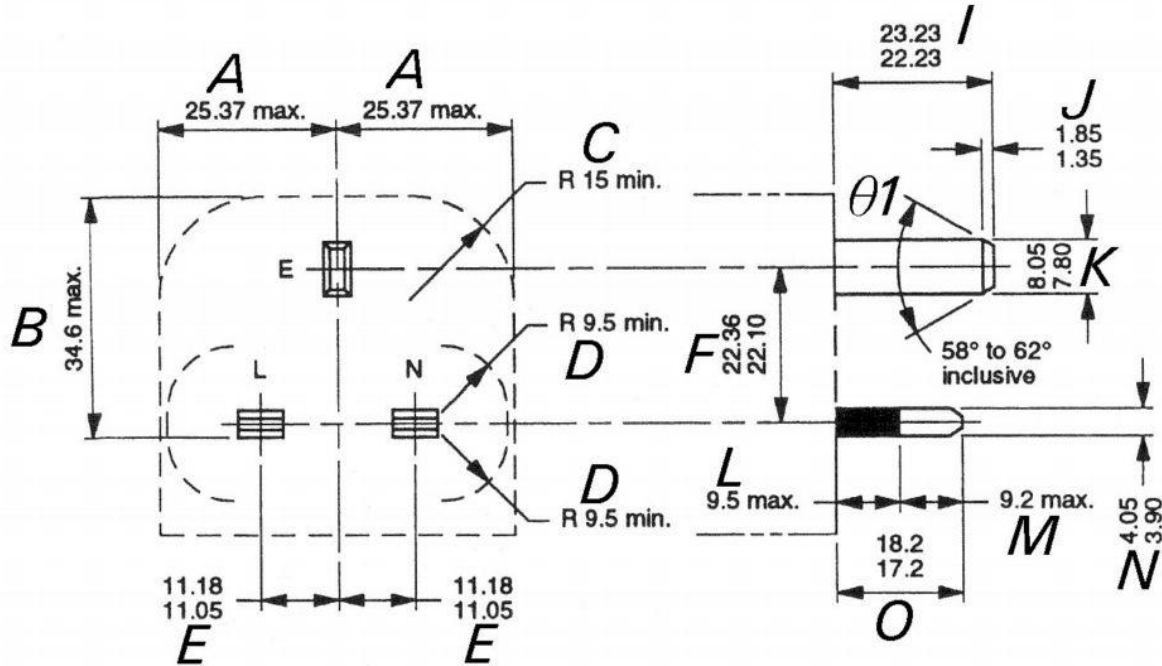

Pin end chamfer detail

All dimensions are in millimetres.

Clause	Requirement – Test	Result - Remark	Verdict
--------	--------------------	-----------------	---------

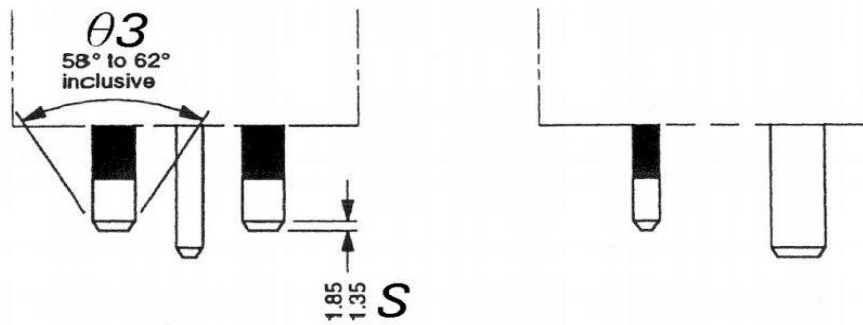

Permitted additional chamfers on L and N pins  
(if additional chamfer is used it has to be on both pins)

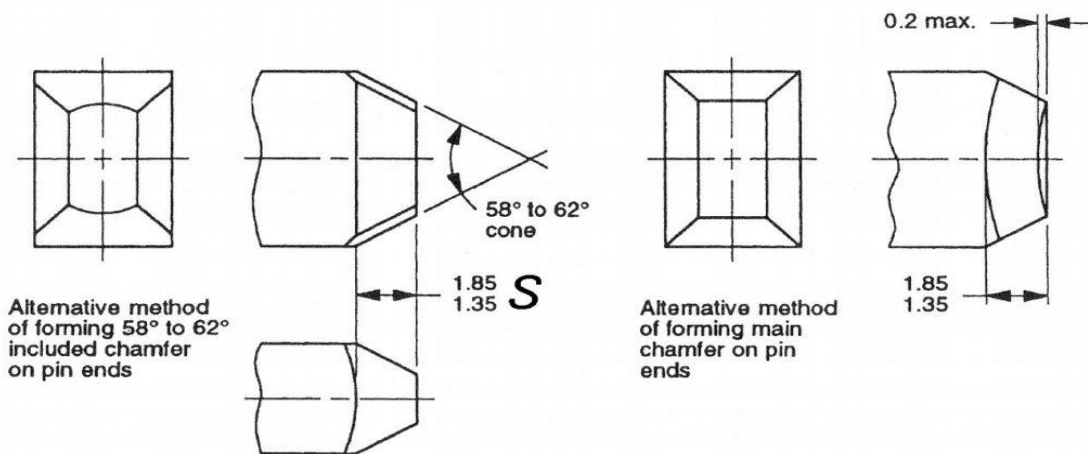

All dimensions are in millimetres.

NOTE 1. External edges of pins are to be free from burrs or sharp edges and may have a radius not exceeding 1 mm.

NOTE 2. The surfaces of pins are to be flat within the specified tolerances.

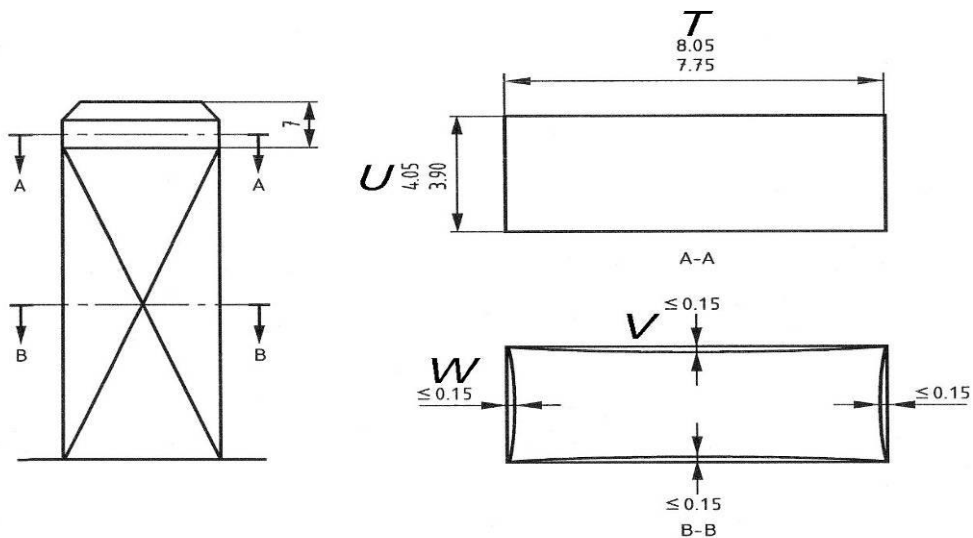

Solid insulated shutter opening device (ISOD)

NOTE Section A-A to be measured away from chamfer as shown.

BS 1363-1: 2016+A1:2018 (Partial)			
Clause	Requirement – Test	Result - Remark	Verdict

Appendix 1 (Refer to 12.2)

**13A Plug Portion Dimensions**

<u>Linear Dimensions (mm)</u>	<u>Measurement</u>	<u>Limit</u>	<u>Verdict</u>
A	24.42	25.37 max.	P
B	16.75	34.6 max.	P
C	--	15 min.	P
D	10.61	9.5 min.	P
E (from L to E)	11.15	11.05 - 11.18	P
(from N to E)	11.16		P
F	22.34	22.10 - 22.36	P
G1	6.32	6.22 – 6.48	P
G2	6.30	6.22 – 6.48	P
H	4.02	3.90 – 4.05	P
I	22.30	22.23 – 23.23	P
J	1.48	1.35 – 1.85	P
K	7.91	7.80 – 8.05	P
L (line)	8.80	9.5 max.	P
(neutral)	8.78		P
M (line)	8.47	9.2 max.	P
(neutral)	8.48		P
N (line) (sleeve)	3.99	3.90 – 4.05	P
(neutral) (sleeve)	3.97		P
O (line)	17.27	17.20 – 18.20	P
(neutral)	17.26		P
P (line)	1.59	1.35 – 1.85	P
(neutral)	1.57		P
(earth)	1.63		P
Q (line) (metal)	3.99	3.90 – 4.05	P

## BS 1363-1: 2016+A1:2018 (Partial)

Clause	Requirement – Test	Result - Remark	Verdict
(neutral) (metal)	3.97		P
(earth) (metal)	--		P
R (line)	1.38		P
(neutral)	1.36	1.2 – 2.0	P
(earth)	1.33		P
S (line/ neutral)	1.59	1.35 – 1.85	P
θ1	59.83°	58° – 62°	P
θ2 (line/ neutral)	69.48°/69.83°	60° – 80°	P
(earth)	69.56°		P
θ3	59.97°	58° – 62°	P
<sup>1)</sup> The outline of the plug is different from shown in figure, but it can insert the gauge fully with a force less than 10 N. So the dimension C is not applicable for the case.			

For solid insulated shutter opening device

<u>Linear Dimensions (mm)</u>	<u>Measurement</u>	<u>Limit</u>	<u>Verdict</u>
T	7.94	7.75 – 8.05	P
U	4.00	3.90 – 4.05	P
V (E → L)	0.10	0.15 max.	P
(E → N)	0.10	0.15 max.	P
W (E → Top)	0.10	0.15 max.	P
(E → L&N)	0.10	0.15 max.	P



JIS C 8303: 2007 (Partial)			
Clause	Requirement – Test	Result - Remark	Verdict

Japanese plug portion test for JP plug portion (MODEL: MC-68-JP)			
APPENDIX II	JIS C 8303: 2007 – PLUGS AND RECEPTACLES FOR DOMESTIC AND SIMILAR GENERAL USE (TYPE INSPECTION)		P
EXPLANATION FOR ABBREVIATIONS P=Pass, F=Fail, N/A=Not applicable. Placed in the column to the right.			
5	Performance		P
5.1	Retaining force	For socket only and movable blade plug only	N/A
5.2	Temperature Rise	For socket only and movable blade plug only	N/A
5.3	Contact resistance	Not required for plug and socket without earth pole	N/A
5.4	Make and Break	For socket only and movable blade plug only	N/A
5.5	Insulation resistance	5M Ohm required after make and break test.	P
5.6	Dielectric withstand voltage	1500V, 10mA, 1 min. required	P
5.7	Resistance to heat	No resin moldings or rubber moldings	P
5.8	Strength of screw terminal and lead-wire joint		P
5.9	Strength of blade fixing part	Tested according to 6.10(3)	P
5.10	Rotating property of movable plug type		N/A
5.11	Strength of enclosure	Tested according to 6.11	P
5.12	Strength of Cord anchorage		N/A
5.13	Strength of Cord outlet		N/A
5.14	Performance of screwless terminals		N/A
5.15	Endurance to ammonia gas	Applied for socket-outlets only	N/A
5.16	Tensile load		N/A
5.17	Waterproof		N/A
5.18	Flame retardance	No supply wire connected	N/A
5.19	Moisture resistance		N/A

6	Construction, dimensions and material		P
6.1	Construction in general		P
6.2	Terminals	AC plug pins were moulded into enclosure directly	N/A
6.3	Insulation	Enclosure material: min. V-0	P
6.4	Materials of conductive metal parts		P
6.5	Material of non-conductive metal parts	No such part	N/A

**JIS C 8303: 2007 (Partial)**

Clause	Requirement – Test	Result - Remark	Verdict
6.6	Shapes and dimensions of blades and blade receiving holes	See measured dimension	<b>P</b>
6.7	Dimensions of mounting parts of recessed socket-outlets		<b>N/A</b>
6.8	Dimensions of cable entry		<b>N/A</b>
6.9	Insulation distance		<b>P</b>
6.10	Symbol of poles	No earth pole or a pole of earth side.	<b>N/A</b>
6.11	Locking type, slip-check connectors		<b>N/A</b>
6.12	Waterproof connectors		<b>N/A</b>
7	Testing methods		<b>P</b>
7.1	Construction test	Considered.	<b>P</b>
7.2	Retaining force test		<b>N/A</b>
7.3	Temperature rise test		<b>N/A</b>
7.4	Contact resistance test		<b>N/A</b>
7.5	Make and break test		<b>N/A</b>
7.7	Insulation resistance test	Considered according to JIS C 8306:1996. see cl. 7	<b>P</b>
7.7	Dielectric withstand voltage test	Considered according to JIS C 8306:1996, see cl. 8	<b>P</b>
7.8	Heat resistance test		<b>P</b>
7.9	Strength test of screw terminal and lead-wire joint		<b>P</b>
7.10	Strength of blade fixing part	For mold on plug pins on thermoplastic material, (2) and (3) considered.	<b>P</b>
	(2): pull test from blade holes, 100N downward for 2 mins		<b>P</b>
	(3): Molded-on connectors		<b>P</b>
	(b) Specimen keep in temperature 20±2°C for 1 hr. in figure 2. blade move right and left 15° for 30 times, 10 times per minute.		<b>P</b>
	(c) Blade fixed as figure 3 move right and left 30° for 5 times.		<b>P</b>
7.11	Enclosure Strength tests		<b>P</b>
	(1) Enclosure compressing test	600N applied on the wider side of specimen between 5mm thick, hardness Ho 60 rubber sheet on top of 15mm or more thick hardwood board for 1 minute.	<b>P</b>

**JIS C 8303: 2007 (Partial)**

Clause	Requirement – Test	Result - Remark	Verdict
	(2) Pendulum free fall test (Impact test)	Height: 1m, Length of cord: 1m	<b>P</b>
	(3) Single body free fall test (Drop test)	Height: 1m	<b>P</b>
7.12	Strength test of Cord anchorage		<b>N/A</b>
7.13	Strength test of Cord outlet		<b>N/A</b>
7.14	Tensile strength test of screwless terminals		<b>N/A</b>
7.15	Bending test for screwless terminal		<b>N/A</b>
7.17	Cyclic heating test for screwless terminal		<b>N/A</b>
7.17	Withstand overcurrent test for screwless terminal		<b>N/A</b>
7.18	Ammonia gas durability test		<b>N/A</b>
7.19	Rotating test of movable plug-blade type		<b>N/A</b>
7.20	Tensile load test		<b>N/A</b>
7.21	Waterproof test		<b>N/A</b>
7.22	Flame retardance test		<b>N/A</b>
8	Inspection		<b>P</b>
8.1	Type inspection	Testing method clause 7 considered. See clause 5, 6 and 10 requirement.	<b>P</b>
10	Marking	Plug portion is an integral part on appliance enclosure, refer to appliance ratings.	<b>P</b>

JIS C 8303: 2007 (Partial)			
Clause	Requirement – Test	Result - Remark	Verdict

Measured dimensions of the plug portion (per JIS C 8303 or IEC 60 083)				P
Location	Measured dimensions (mm)			Limit of dimensions (mm)
	Sample 1	Sample 2	Sample 3	
A	14.12	14.10	14.14	Under 14,6
B	11.14	11.16	11.12	Over 10,8
C	1.49	1.47	1.51	1,5 ± 0,15
D	6.28	6.27	6.28	6,3 ± 0,3
E	6.29	6.28	6.27	8 ± 0,2 <sup>1)</sup>
F	3.24	3.23	3.25	Φ 3 + 0,3 / - 0,2
G	3.73	3.72	3.75	Over Φ 3,5
H	11.81	11.79	11.83	11,7 ± 0,4
J	16.21	16.19	16.18	17 ± 1,3
K	0.82	0.79	0.82	Under 0.9

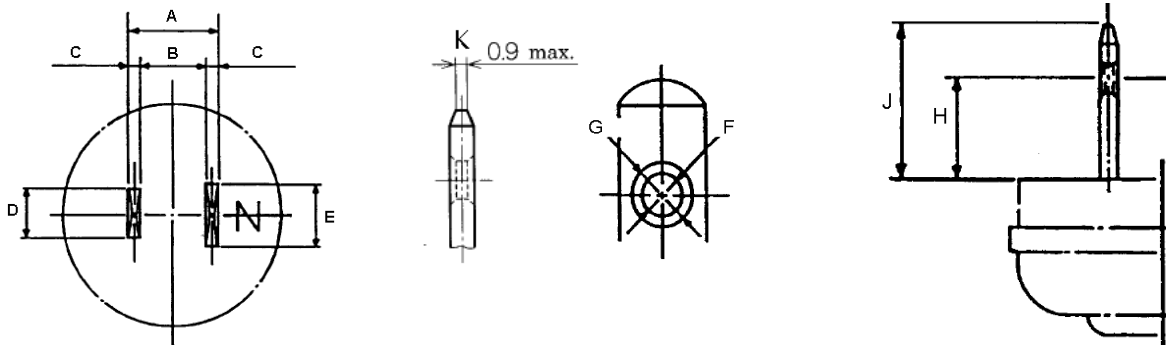

Notes:

1) In case of those without having distinction of polarity, the width of blade shall be 6,3mm ± 0,3 mm.

2) The original requirement in JIS C 8303:2007 is 1,5 ± 0,1 mm. However, based on DENAN technical interpretation issued by METI, the original requirement is replaced by the dimension of DENAN Appendix 4 (1,5 ± 0,15 mm) in this TRF.

JIS C 8303: 2007 (Partial)

Clause	Requirement – Test	Result - Remark	Verdict
--------	--------------------	-----------------	---------

Additional requirement for plug pins covered with resin mold ( <i>pins with insulated material</i> )				N/A
Location	Measured dimensions (mm)			Limit of dimensions (mm)
	Sample 1	Sample 2	Sample 3	
a	--	--	--	<6.7
b	--	--	--	<1.9
c	--	--	--	<5.0
W	--	--	--	6,3 ± 0,3
T	--	--	--	1,5 ± 0,15

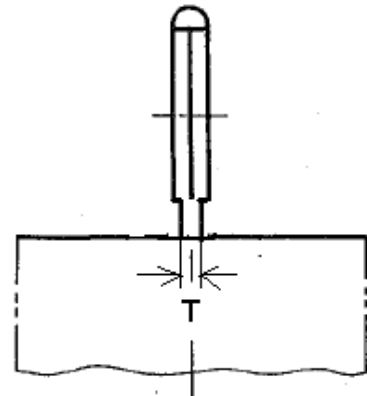
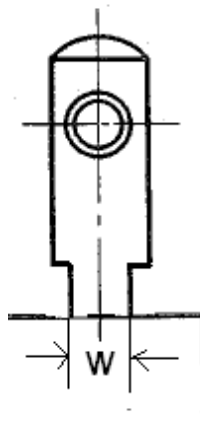
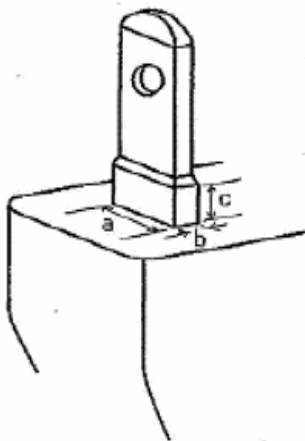

Notes:

1) W and T were tested with the resin mold removed.

IRAM 2063:2009 (Partial)			
Clause	Requirement – Test	Result - Remark	Verdict

**Argentina plug dimension check according to IRAM 2063:2009**

Plug dimensions (IRAM 2063: 2009) (plug portion model MC-68-AR)				
Location	Requirement	Measured	Verdict	
Marking of neutral with N	Fig. 3	marked	P	
A: Distance from edge to L and N pins	min. 8 mm	9.38 mm	P	
Distance between pin center	13.72±0.1 mm	13.74 mm	P	
g: Pin length	18.2±0.2 mm	18.28 mm	P	
a: Pin width	6.25±0.1 mm	6.29 mm	P	
e: Pin thickness	1.55±0.07 mm	1.59 mm	P	
b: Pin center to plug center	7.92 mm	7.92 mm	P	
One half distance of pin center to pin center	6.86±0.1 mm	6.87 mm	P	
Maximum dimensions of the outer perimeter (mm)	I	Max. 22 mm	21.02 mm	P
	K	Max. 22 mm	10.38 mm	P
	J	Max. 44 mm	42.02 mm	P
	L	Max. 44 mm	28.42 mm	P
Pin angle	120°±5'	120°	P	
Ending of the contact pins be rounded	Fig. 4a or 4b	Rounded as Fig. 4a	P	

Table 1: Table 1 - Measures of the plug (mm)

Ficha	a	b	e	g
10 A	6,25 ± 0,10	7,92	1,55 ± 0,07	18,2 ± 0,2

Minimum outer perimeter measures  
A= 8 mm

Dashed line refers only the minimum of construction.

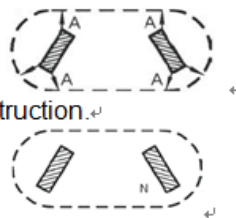
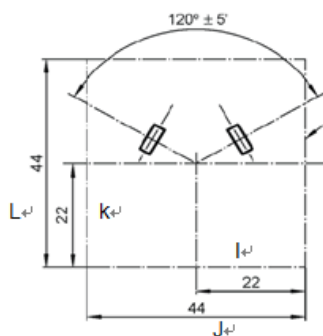
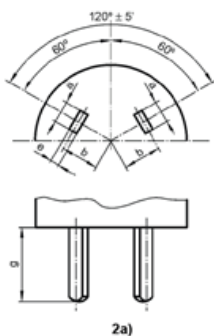

Figure 1 - Identification of the plug pins, seen from the pins



Maximum dimensions of the outer perimeter (mm)

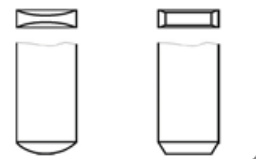
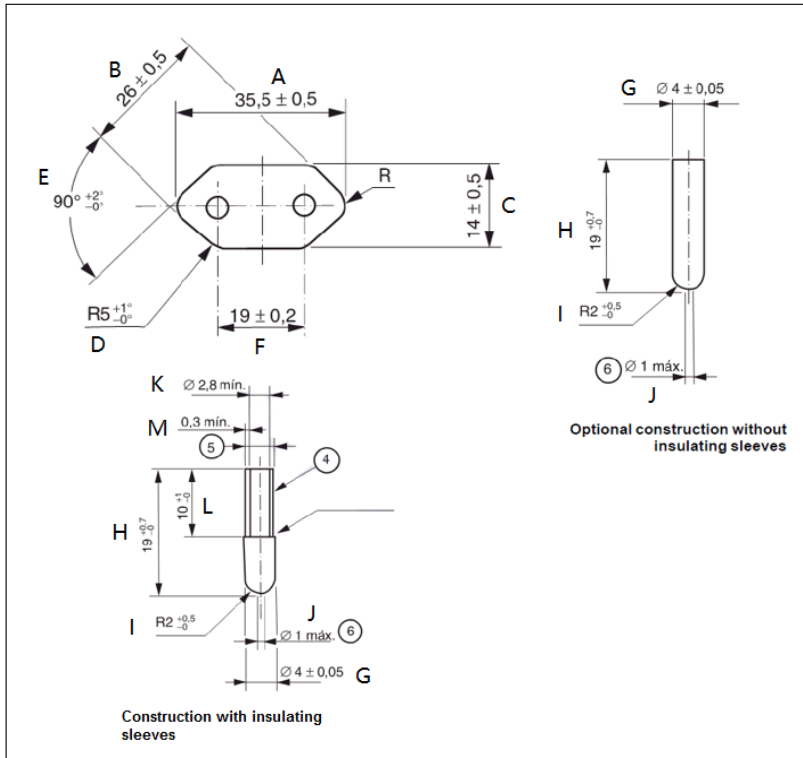

Figure 2 - Measures of the plug ..... Figure 4a and 4b - Ends of the connection blades

## NBR 14136 (Partial)

Clause	Requirement – Test	Result - Remark	Verdict
--------	--------------------	-----------------	---------

**Brazilian plug dimension check according to NBR 14136: BR plug portion(MC-68-BR)**

Symbol	Requirement (mm)	Measured (mm)	Symbol	Requirement (mm)	Measured (mm)
A	35.5 ± 0.5	35.82	J	1.0 max.	0.9
B	26 ± 0.5	26.02	K	2.8 min.	--
C	14 ± 0.5	14.27	L	10.0 – 11.0	--
D	R 5 – 6	5.6	M	0.3 min.	--
E	90° – 92°	90.8°			
F	19 ± 0.2	18.89			
G	4 ± 0.5	3.99			
H	19.0 – 19.7	19.28			
I	R 2 – 2.5	2.3			

Note:

 Plug construction with insulating sleeves.  Plug construction without insulating sleeves.

SASO 2203:2018(Partial)			
Clause	Requirement – Test	Result - Remark	Verdict

<b>SASO 2203:2018 plug portion: (Saudi plug portion MODEL: MC-68-UK)</b>			
<b>All tests shall be performed as per clause 5 of the standard BS 1363-1:2016+A1</b>			
<b>Related tests of BS 1363-1:2016 as below:</b>			
<b>12</b>	Construction of Plugs		<b>P</b>
12.1	The disposition of the pins shall be shown as figure 4.	The dispositions of the pins were shown as figure 4.	P
12.2	Pin and sleeve dimensions, body outline were checked according to figure 4 of BS1363: Part 1.	9.30 mm was measured from the engagement surface. (It shall not less than 6.35 mm)	P
		The dimensions were found within the specified limits as shown in figure 4. (please refer to attached appendix 1 for details)	P
	The plug portion shall enter the gauge fully with a force less than 10N was applied to the centre of the sample at right angle	Sample could enter into the gauge fully with a force less than 10 N.	P
12.3	No parts of a line or neutral pin shall be less than 9.5mm from the periphery of the plug measured along the engagement surface.	Complied.	P
12.9	Plug pins were constructed of brass or nickel plated brass	Brass.	P
12.9.1	Exposed surface of plug pins were smooth and free from burrs or sharp edges and other irregularities, which could cause damage or excessive wear to sockets or shutters.	Complied.	P
12.9.4	The adaptor plug pins were tested as specified in the standard.	After test at 1100 N, the pin portions couldfit the relevant gauge.	P
12.9.5	Plugs with nickel plated brass shall not cause excessive wear to socket contacts or shutters of socket-outlets.	See below	P
	Each plug is inserted into and withdrawn from the socket-outlet at a rate of six insertions and six withdrawals per minute, the speed of travel of the plug being approximately 150 mm/s. The periods during which the plug is inserted and withdrawn shall be approximately equal. The plug pins are renewed or a new plug is used after each 5 000 insertions and withdrawals.	The socket-outlet show no sign of damage that would impair further use. The plugs show no damage and conform to the dimensional requirements of 12.2. The shutters of the socket-outlet operate satisfactorily and the socket contacts shall be safely shielded.	P
12.9.6	Each pin of the adapter was subjected to a torque of 1Nm for 60s as specified in the standard.	After the test, the pin portion couldfit the relevant gauge.	P



SASO 2203:2018(Partial)			
Clause	Requirement – Test	Result - Remark	Verdict
12.11	The adaptors were tested as specified in standard. After being placed in an oven at 70°C for 1 hour, each pin of the samples was subjected for 60s to a pull of 100N in the oven.	After the test, no plug pin was detached and the plug pins could fit the relevant gauge.	P
12.12	The degree of the flexibility of mounting of the plug pins was checked by inspection	Complied.	P
12.13	Suitable means shall be provided for withdrawing the plug without subjecting the flexible cord to stress.	Complied.	P
12.16	Line and neutral plug pin shall be fitted with insulating sleeves. The dimensions of the pin and sleeve shall fall within the specific limit.	Both line and neutral pins were fitted with insulating sleeve.	P
12.17.1	Plug pin sleeve shall be compliance with 12.17.2 to 12.17.4	Complied.	P
12.17.2	Electric strength test applied between the metal part of the plug pin and the sleeve. (1250V±30V for 60s)		P
12.17.3	Abrasion test for plug pin sleeve The plug pin sleeves were subjected to 20000 movements of abrasion as specified in the standard.	After the test, the sleeves showed no damage that impaired further use and could satisfy the electric strength test in 12.17.2	P
12.17.4	Resistance to deformation The plug pins with sleeves were placed in a heating cabinet at 200°C and tested according to the standard for 120min. The test shall be carried out at 125°C based on the UK deviation to clause 4.3.6 for Direct plug-in equipment in IEC 62368-1:2018	After the test carried out at 125 °C for 120 min, only slightly impression observed, the impressions were less than 50 % of the thickness measured before the test.	P
22.2	Parts of insulating material shall be sufficiently resistant to heat and still shaving its location and function.	Complied. See 22.2.1	P
22.2.1	Compliance checked as follows: a) Parts of ceramic material are used; b) external parts of plugs tested according to 22.1.3; c) all other parts of insulating material including ISOD subjected to the ball pressure at a temperature of 75°C ± 5°C	See appended table 22.2.1	P
23	Resistance to abnormal heat, fire and tracking		P
23.1	Plugs shall be proof against abnormal heat, fire and tracking		P
23.1.1	Compliance shall be checked by the test described in 23.2		P

SASO 2203:2018(Partial)			
Clause	Requirement – Test	Result - Remark	Verdict

23.2	<p>Glow-wire test</p> <p>The test is performed according to BS EN 60695-2-11:2014 and at the test temperature given in Table 10</p> <p>b) Parts necessary to retain live parts in position including ISOD were tested at 750°C.</p> <p>Parts not necessary to retain live in position were tested at 650°C.</p>	See appended table 23.2	P
------	-----------------------------------------------------------------------------------------------------------------------------------------------------------------------------------------------------------------------------------------------------------------------------------------------------------------	-------------------------	---

**Additional Requirements (Clause 12.2, 12.9.4.3, 12.9.5, 12.9.6, 22.2 and 23) for the ISOD  
According to the standard BS 1363-1**

12.2	Solid insulated shutter opening device should comply all the dimensions specified in Figure 4 with exception of the width of the ISOD should be 4.05 mm maximum and 3.90 mm minimum. and its height which should be 8.05 mm maximum and 7.75 mm minimum	The measured dimensions were found to be within the specified limits. (see attached appendix 1 for details)	P
12.9.4	Solid insulated shutter opening device were tested as specified in the standard.	After subjected to a force of 400N, the pin portion still could fit the relevant gauge.	P
12.9.5	Plugs with ISOD shall not cause excessive wear to socket contacts or shutters of socket-outlets.	See below	P
	Each plug is inserted into and withdrawn from the socket-outlet at a rate of six insertions and six withdrawals per minute, the speed of travel of the plug being approximately 150 mm/s. The periods during which the plug is inserted and withdrawn shall be approximately equal. The plug pins are renewed or a new plug is used after each 5 000 insertions and withdrawals.	<p>The socket-outlet show no sign of damage that would impair further use.</p> <p>The plugs show no damage and conform to the dimensional requirements of 12.2.</p> <p>The shutters of the socket-outlet operate satisfactorily and the socket contacts shall be safely shielded.</p>	P
12.9.6	ISOD of the adapter was subjected to a torque of 1Nm for 60s as specified in the standard.	After the test, the pin portion could fit the relevant gauge.	P

22.2.1	<b>TABLE: Ball-pressure test</b>						
	Specimen			Ball-pressure test			
Part	Material	Material-thickness [mm]	Colour	[C°]	Measured [mm]	Required [mm]	Result
Plug portion (including ISOD)	LOTTE CHEMICAL CORPORATION / HN-1064(+)	1.5mm*2	Black	75	0.9	< 2.0	Pass
Plug portion (including ISOD)	SABIC INNOVATIVE PLASTICS US L L C / 945 (GG)	1.5mm*2	black	75	0.9	< 2.0	Pass

SASO 2203:2018(Partial)							
Clause	Requirement – Test				Result - Remark		Verdict

Plug portion (including ISOD)	SABIC JAPAN L L C / 945 (GG)	1.5mm*2	black	75	1.0	< 2.0	Pass
Plug portion (including ISOD)	COVESTRO DEUTSCHLAND AG [PC RESINS] / FR6005	1.5mm*2	black	75	1.0	< 2.0	Pass
Plug portion (including ISOD)	DONGGUAN HUAZHE METALS & PLASTICS LTD / HZ-88	1.5mm*2	black	75	1.0	< 2.0	Pass

Supplementary information:

23.2	TABLE: Glow-wire-test [60 s]								
Specimen				Flame					
Part	Material	Material-thickness [mm]	Colour	[°C]	Start [s]	End [s]	Height [mm]	Ignition of tissue paper	Result
Enclosure/ Plug portion (including ISOD)	LOTTE CHEMICAL CORPORATION / HN-1064(+)	1.5mm*2	black	750	--	--	--	No	Pass
Enclosure/ Plug portion (including ISOD)	SABIC INNOVATIVE PLASTICS US L L C / 945 (GG)	1.5mm*2	black	750	--	--	--	No	Pass
Enclosure/ Plug portion (including ISOD)	SABIC JAPAN L L C / 945 (GG)	1.5mm*2	black	750	--	--	--	No	Pass
Enclosure/ Plug portion (including ISOD)	COVESTRO DEUTSCHLAND AG [PC RESINS] / FR6005	1.5mm*2	black	750	--	--	--	No	Pass
Enclosure/ Plug portion (including ISOD)	DONGGUAN HUAZHE METALS & PLASTICS LTD / HZ-88	1.5mm*2	black	750	--	--	--	No	Pass

Supplementary information:

Clause	Requirement – Test	Result - Remark	Verdict
--------	--------------------	-----------------	---------

UK plug portion for switching power adapter

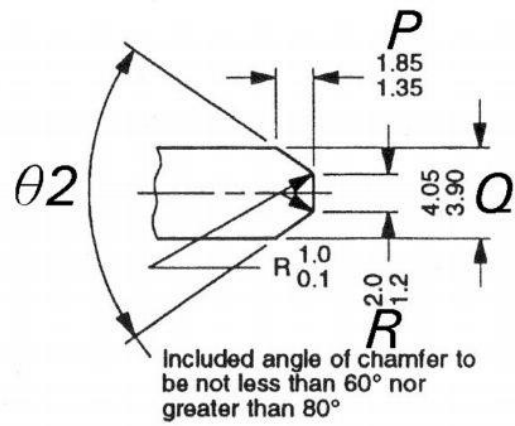
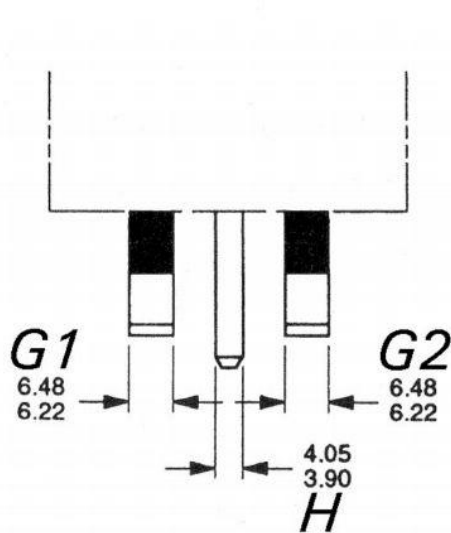
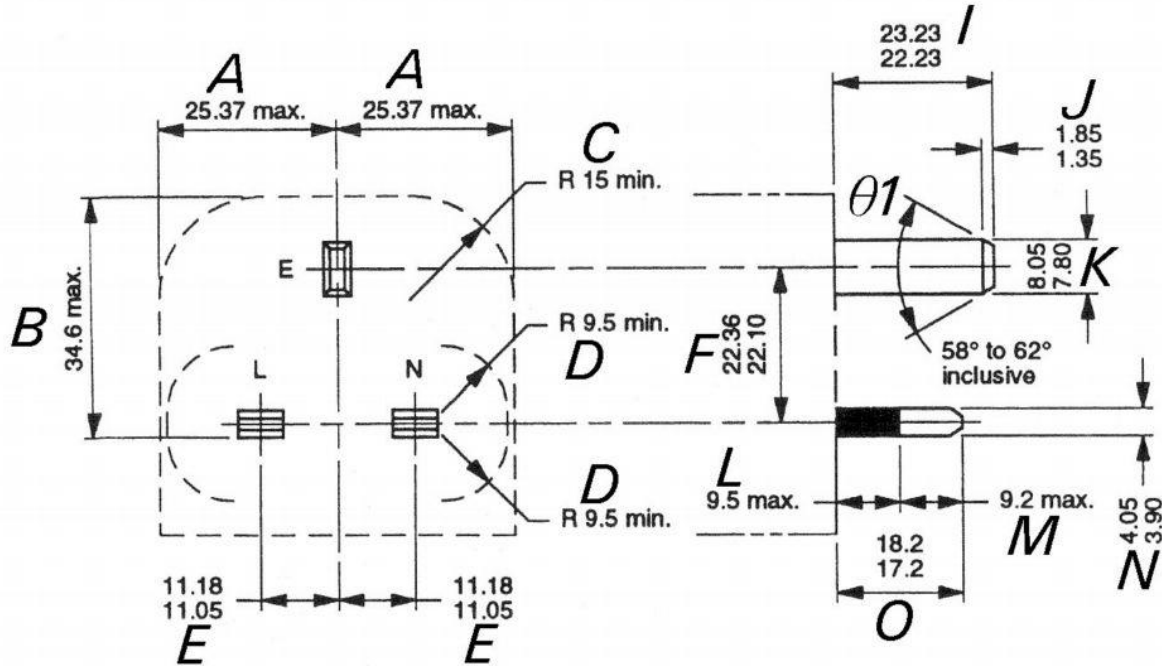

Pin end chamfer detail

All dimensions are in millimetres.

SASO 2203:2018(Partial)

Clause	Requirement – Test	Result - Remark	Verdict
--------	--------------------	-----------------	---------

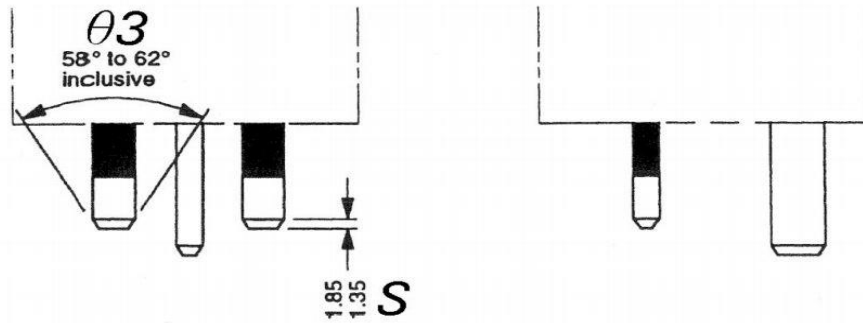

Permitted additional chamfers on L and N pins  
(if additional chamfer is used it has to be on both pins)

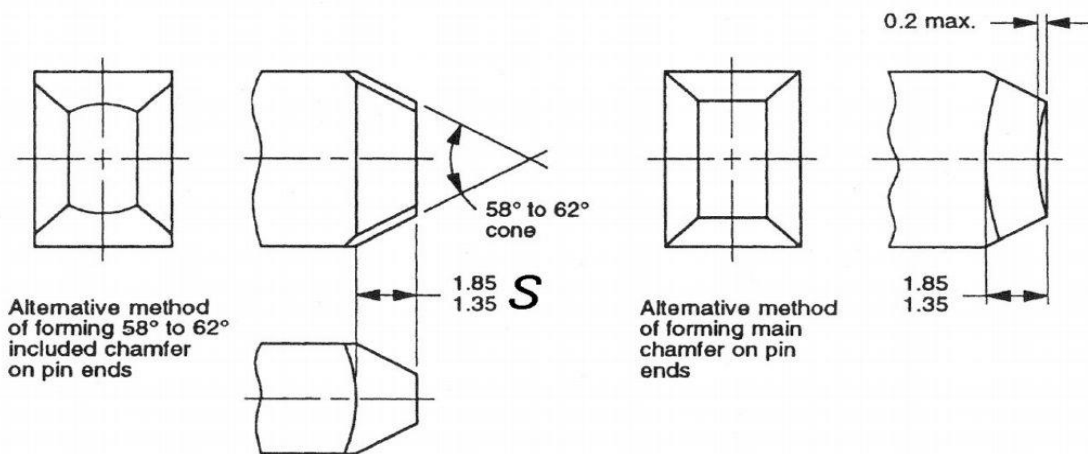

All dimensions are in millimetres.

NOTE 1. External edges of pins are to be free from burrs or sharp edges and may have a radius not exceeding 1 mm.

NOTE 2. The surfaces of pins are to be flat within the specified tolerances.

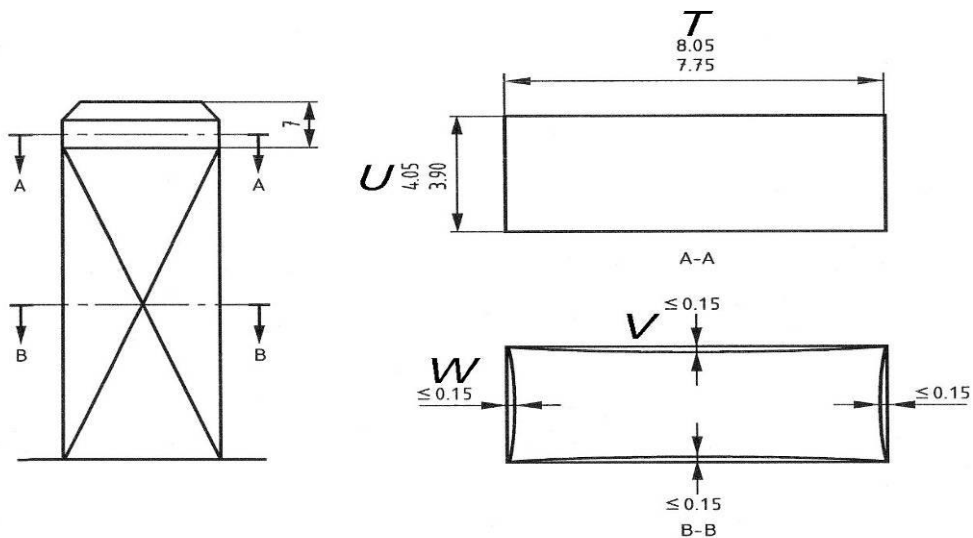

Solid insulated shutter opening device (ISOD)

NOTE Section A-A to be measured away from chamfer as shown.

SASO 2203:2018(Partial)			
Clause	Requirement – Test	Result - Remark	Verdict

Appendix 1 (Refer to 12.2)

**13A Plug Portion Dimensions**

<u>Linear Dimensions (mm)</u>	<u>Measurement</u>	<u>Limit</u>	<u>Verdict</u>
A	24.42	25.37 max.	P
B	16.75	34.6 max.	P
C	--	15 min.	P
D	10.61	9.5 min.	P
E (from L to E)	11.15	11.05 - 11.18	P
(from N to E)	11.16		P
F	22.34	22.10 - 22.36	P
G1	6.32	6.22 – 6.48	P
G2	6.30	6.22 – 6.48	P
H	4.02	3.90 – 4.05	P
I	22.30	22.23 – 23.23	P
J	1.48	1.35 – 1.85	P
K	7.91	7.80 – 8.05	P
L (line)	8.80	9.5 max.	P
(neutral)	8.78		P
M (line)	8.47	9.2 max.	P
(neutral)	8.48		P
N (line) (sleeve)	3.99	3.90 – 4.05	P
(neutral) (sleeve)	3.97		P
O (line)	17.27	17.20 – 18.20	P
(neutral)	17.26		P
P (line)	1.59	1.35 – 1.85	P
(neutral)	1.57		P
(earth)	1.63		P
Q (line) (metal)	3.99	3.90 – 4.05	P

SASO 2203:2018(Partial)			
Clause	Requirement – Test	Result - Remark	Verdict
(neutral) (metal)	3.97	1.2 – 2.0	P
(earth) (metal)	--		P
R (line)	1.38		P
(neutral)	1.36		P
(earth)	1.33		P
S (line/ neutral)	1.59	1.35 – 1.85	P
θ1	59.83°	58° – 62°	P
θ2 (line/ neutral)	69.48°/69.83°	60° – 80°	P
(earth)	69.56°		P
θ3	59.97°	58° – 62°	P
<sup>1)</sup> The outline of the plug is different from shown in figure, but it can insert the gauge fully with a force less than 10 N. So the dimension C is not applicable for the case.			

For solid insulated shutter opening device

<b><u>Linear Dimensions (mm)</u></b>	<b><u>Measurement</u></b>	<b><u>Limit</u></b>	<b><u>Verdict</u></b>
T	7.94	7.75 – 8.05	P
U	4.00	3.90 – 4.05	P
V (E → L)	0.10	0.15 max.	P
(E → N)	0.10	0.15 max.	P
W (E → Top)	0.10	0.15 max.	P
(E → L&N)	0.10	0.15 max.	P

## SASO 2203:2018(Partial)

Clause	Requirement – Test	Result - Remark	Verdict
--------	--------------------	-----------------	---------

<b>4</b>	<b>MATERIALS, DESIGN AND CONSTRUCTION</b>		—
4.1	Materials and construction	Comply	P
4.2	Terminals		N/A
4.3	Plugs	Refer to above BS 1363-1 Plug portion dimension result.	P
4.4	Socket-outlets		N/A
4.5	Clearance and creepage distances	Refer to main report test result.	P
<b>5</b>	<b>RATING AND CHARACTERISTICS</b>		—
5.1	Rating shape and dimensions		P
5.2	Protection against electric shock		P
5.3	Insulation resistance		P
5.4	Electrical strength		P
5.5	Temperature rise		P
5.6	Contact resistance	Refer to cl. 12.9.5 of BS 1363-1	P
5.7	Current breaking capacity of socket contacts		N/A
5.8	Normal operation		N/A
5.9	Resistance to heat	Refer to cl. 22 of BS 1363-1 test result.	P
5.10	Mechanical strength	Should be checked by end product	N/A
5.11	Resistance to abnormal heat and fire		P
5.12	Resistance to ageing and humidity		P
5.13	Resistance to excessive residual stresses and to rusting		P



AS/NZS 3112: 2017+A1:2021 (Partial)			
Clause	Requirement – Test	Result - Remark	Verdict

Appendix J of AS/NZS 3112: 2017+A1:2021 (MODEL: MC-68-AU)			
J1	Scope		P
J2	Definitions		P
J2.1	Detachable plug portion		N/A
	(a) Type A (see Figure J1)		N/A
	(b) Type B (see Figure J2)		N/A
	(c) Type C (see Figure J3)		N/A
J2.2	Integral plug portion		P
	A plug portion that is integral to the equipment enclosure and is not detachable.		P
J2.3	Plug portion		P
	The portion of equipment with integral pin shown in Figure 2.1, including the plug pins, terminals of the plug pins and external dimensions of the 'maximum projection'.		P
J3	Requirements for plug portion		P
J3.1	General		P
	The following provisions apply to the dimensions apply to the dimensional and constructional requirements of the plug portion of equipment	See appendix 1	P
	and any detachable connection for (a) to (d).		N/A
	(a) For detachable plug portions intended for connection to the equipment in multiple orientations, the relevant tests are performed in the most onerous orientation.		N/A
	(b) For Type A detachable plug portion, the relevant requirements of AS/NZS 3105 are applicable, in addition to conformance with relevant clauses of this Appendix.		N/A
	(c) For Type B detachable plug portions, the conformance is shown by the relevant clauses of this Appendix.		N/A
	(d) For Type C detachable plug portions, conformance is shown by assessment to Section 2 of this Standard (plugs) and relevant clauses of this Appendix.		N/A
J3.2	Plug pin of plug portions:	See below	P
	The requirements of clause 2.2 are applicable for plug pins.	See cl. 2.2	P

## AS/NZS 3112: 2017+A1:2021 (Partial)

Clause	Requirement – Test	Result - Remark	Verdict
Clause 2.2 Clause 2.2.1	Material for pins: Current carrying parts of plug pins shall be of metal having, under the conditions occurring in the plug, sufficient mechanical strength, electrical conductivity and resistance to corrosion adequate for their intended use. Compliances shall be check by inspection and where in doubt, by chemical analysis.	See below	P
	a) copper;		N/A
	b) copper alloy containing at least 58% copper for parts made from cold rolled sheet or at least 50% copper for other parts; or	Brass, Cu:>58%	P
	c) stainless steel containing at least 13% chromium and not more than 0.09% carbon.		N/A
Clause 2.2.2	Assembly of pins: Where, during assembly, pin may become detached from the body of a plug yet remain attached to the conductors of a flexible cord, or have to be detached from the body to enable connection, it shall not be possible for a plus to be assembled with any pin located in a position other than that intended.  In a plug made of resilient insulating material, the pins and terminals shall be held securely in position.	Moulded on the plug portion	P
Clause 2.2.3	Form of pin: The plug pins shall be adequately proportioned throughout and the portion adjacent to the connection shall be designed so as not to introduce a stress concentration which may lead to a fracture of the pin, and shall be suitably shaped to prevent abrasion or cutting of conductor strands due to flexure in normal use.	It can easily enter into the gauge without additional force applied. No sharp edges	P
	The exposed ends of plug pins shall have a bevel or radius to facilitate entry into socket-outlets and to operate shutters.	See below	P
	Round pins shall have a semicircular end profile.		P
	Flat pins with the following width and thickness profiles are deemed to comply:	See below	P
	a) Flat-pins with a radius on the end with side bevels, as shown in figure 2.1(h), may have a -	See appendix 1	P
	- i) width profile with an arc on the centre line of the pin of -	See appendix 1	P
	A) 6 mm for all pins of 10A plugs and live pins of 15A plug; or	See appendix 1	P
	B) 11 mm for each pins of 15A plugs and all pins of 20A plug; and	10 A plug	N/A

## AS/NZS 3112: 2017+A1:2021 (Partial)

Clause	Requirement – Test	Result - Remark	Verdict
	- ii) thickness profile with each corner beveled 0.3 mm to 0.4 mm along the sides finishing along the pin at 0.8 mm to 1.0 mm.	See appendix 1	P
	b) Flat-pins square on the end with corner bevels and side bevels, as shown in figure 2.1(i), may have a -	Flat-pins with radius on the end with side bevels	N/A
	- i) width profile which is square and with each corner beveled 0.6 mm finishing along the pin at 0.8 mm to 1.0 mm; and		N/A
	- ii) thickness profile with each corner beveled 0.3 mm to 0.4 mm along the sides finishing along the pin at 0.8 mm to 1.0 mm.		N/A
	c) Flat-pins square on the end with corner bevels and a radius on the sides, as shown in figure 2.1(j), may have a -	Flat-pins with radius on the end with side bevels	N/A
	- i) width profile which is square and with each corner beveled 0.6 mm finishing along the pin at 0.8 mm to 1.0 mm; and		N/A
	- ii) thickness profile with a radius of approximately half the material thickness along the sides, finishing along the pin at 0.8 mm to 1.0 mm.		N/A
	The contact portion of the pin shall be smooth and free from openings or indentations; however, for flat pin plug, a longitudinal seam or opening in the contact portion of one face up to 0.3 mm width is deemed to comply. The thickness of any pin at the seam is measured using a 0.3 mm thick blade as indicated in Figure 2.3	Smooth, no seam	P
	The exposed portion of plug pins of other than insulated pin plug shall be free from any non-metallic coverings or coatings.		P
Clause 2.2.4	Insulation of plug pins: Live parts of insulated pin plugs shall not be exposed when the plug is partially or fully engaged with the associated socket	See below	P
	Compliance for plugs of the types shown in figure 2.1 is checked by measurement to Figure 2.4	See appendix 1	P
	For purpose of this clause, lacquer, enamel or sprayed insulating coating is not considered to be insulation material.	No such materials used	P
	All live pins on low voltage plugs except for those shown in Figure 2.1(a2), (b) and (g) shall be of the insulated pin type from 5 years after the publication of this Standard.	Insulated pin sleeve used	P
J3.3	Rating and dimensions for low voltage plug portions:	See below	P
	The requirements of clause 2.8.1 and 2.8.4 are applicable for ratings and dimensions.	See cl. 2.8.1 and 2.8.4	P

## AS/NZS 3112: 2017+A1:2021 (Partial)

Clause	Requirement – Test	Result - Remark	Verdict
Clause 2.8.1	Plugs with ratings up to and including 20 A, shall conform to the appropriate dimensions shown in Figure 2.1.	Two-pin plug. Complying with Figure 2.1(c), (e)	P
	In addition to dimensions of Figure 2.1, the distance between a live part pin of any plug and the edge of the moulding of the plug, shall be not less than 9 mm. Where doubt exists regarding compliance with this requirement, the gauge of Figure A1 in Appendix A or Figure B1 in Appendix B, or Figure F1(a) or Figure F1(b) in Appendix F, as appropriate, shall be place over the pin so as to contact the highest points associated with the plug face between the plug and the plug gauge, penetration to within 9 mm of the live pin shall not be possible.	The distance between a live part pin of any plug and its edge:9.50 mm ( required: >9 mm )	P
	No point on the front face of the plug shall protrude by more than 0.5 mm. The pin lengths shall be measured from a plane normal to the pin passing through the highest point on the front face of the plug, to the end of the pin.	No point on the front face of the plug with protrusion	P
Clause 2.8.4	Compliance with dimensional requirements of Figure 2.1	See appendix 1	P
	Low voltage plug shall be checked for compliance with the prescribed dimensions of Figure 2.1 by any suitable means, except that compliance with the nominal dimensions covering disposition of pins, i.e. spacing from centre and angular orientation, shall be checked by a gauge complying with Appendix A, Appendix B or Appendix F, as appropriate.	See appendix 1	P
	In addition, low voltage flat-pin, or combination of flat and round pin, plug having ratings up to 15A of the Figure 2.1(a1), Figure 2.1(c), Figure 2.1(d), Figure 2.1(f) or Figure 2.1(g) type, shall comply with the dimensional requirements of Figure 2.1(e1 and e2).	Two-pin plug. Complying with Figure 2.1(c), (e). See appendix 1	P
	20 A plugs of the Figure 2.1(a2) type shall comply with the dimensional requirements of Figure 2.1(e2).		N/A
	Plugs with insulated pins, complying with this Standard, need not comply with dimension R20 $\pm 1.0$ mm of Figure 2.1(e2) provided there is at least 9mm from the edge of the live pins to the edge of the plug face Figure 2.1(e3).	Insulated pins used	P
J3.4	Internal connections for plug portions:	See below	P
	Internal connections for plug portions: The requirements of Clause 2.9 are applicable for internal connections unless requirements are contained in the relevant product standard.	See cl. 2.9	P

## AS/NZS 3112: 2017+A1:2021 (Partial)

Clause	Requirement – Test	Result - Remark	Verdict
Clause 2.9	Internal connections	See below	N/A
	The design and construction of a plug provided with earthing connections shall be such that when the plug is correctly wired and completely assembled:	Two-pin plug	N/A
	a) a loose terminal screw or conductive material cannot bridge and live parts or earthing parts;		—
	b) the earthing parts are effectively isolated from contact with a live conductor which may become detached ; and		—
	c) the live parts are effectively isolated from contact with any earthing conductor which may become detached		—
	Any connections for auxiliary devices, such as radio interference suppressors or visual indicators, shall comply with the above requirements.	Compliance shall be checked by end-product standard	N/A
J3.5	Arrangement of earthing connections for plug portions	Two-pin plug	N/A
	The requirement of Clause 2.10 are applicable for arrangement of earthing connections.		N/A
Clause 2.10	The earthing pin of any low voltage, three-pin plug shall be that pin which is radial to the circle embracing the pins (see Figure 2.1(a), Figure 2.1(f), Figure 2.1(g)).	Two-pin plug	N/A
J3.6	Configuration of plug portions	See below	P
	The requirement of Clause 2.12.6 are applicable for configuration of plug portions	See cl. 2.12.6	P
Clause 2.12.6	A plug conforming to Figure 2.1(a), Figure 2.1(c), Figure 2.1(f) or Figure 2.1(g) shall have its pins disposed as that, when the pins are correctly connected, the pin configuration, viewed as from the pins, shall be earth, neutral and active in a clockwise direction.	Conforming to figure 2.1(c)	P
	Where there is no earthing, the live part pins shall conform to this configuration	Two-pin plug	N/A
<b>J4</b>	<b>Test</b>		<b>P</b>
J4.1	General		P
	Plug portions of equipment with integral pin shall be subjected to the following tests and unless stated otherwise, shall comply with the requirement specified in section 2 for each test. The number of test samples shall be in accordance with table J1. (AS/NZS 3112:2017/A1:2021)	The number of test samples used in accordance with table J1	P

## AS/NZS 3112: 2017+A1:2021 (Partial)

Clause	Requirement – Test	Result - Remark	Verdict
	For equipment with a detachable plug portion, the assessment(s) of Table J1 tests 2, 3, 5, 10 and 11 shall be conducted on the—  (a) assembled equipment with the detachable plug portion connected; and  (b) the detachable plug portion after it has been separated from the equipment (AS/NZS 3112:2017/A1:2021)		P
J4.2	High voltage test	See below	P
	The requirement of clause 2.13.3 are applicable unless requirements are contained in the relevant product standard.	See cl. 2.13.3	P
Clause 2.13.3	High voltage test		P
	The plug shall withstand without failure an a.c voltage of the value indicated in table 2.3, applied between the parts set out in item (a) and (c) of clause 2.13.2 for 1 min. in each case		P
	a) Between all poles of the plug, taken in pairs.	Applied 1000 V a.c.	P
	c) Between live poles of plug and the earthing terminal of exposed metal, the live poles being connected together.	Applied 1000 V a.c.	P
	The plug shall further withstand, without failure, a voltage of 3000 V a.c. applied between the parts set out in Items (b) and (d) of clause 2.13.2 for 1 min. in each case.		P
	b) Between live poles of plug and any external metal, all live poles of plug being connected together.	To be evaluated by end product standard	N/A
	d) Between live poles and a flexible electrode applied to non-conducting parts normally handled in service all live poles connected together.	Applied 3000 V a.c. to live parts with metal foil wrapping over insulated mouldings	P
	The insulation of insulated pin plugs shall withstand a voltage of 1250V a.c. for 1 min applied in accordance with Clause 2.13.2(e)	See below	P
	e) for insulated pin plug, between live poles and a metal foil applied around the insulation on each live pin for a distance of approximately 4 mm from plug face, all live poles being connected together.	Applied 1250 V a.c. to live parts with metal foil wrapping over insulated pin	P
J4.3	Mechanical strength of pin test	See below	P
J4.3.1	Tumbling barrel test	See below	P
	The tumbling test is applied to determine the mechanical strength of the plug portions and equipment having integral or detachable plug portions.		P

AS/NZS 3112: 2017+A1:2021 (Partial)			
Clause	Requirement – Test	Result - Remark	Verdict
	For equipment with a detachable plug portion, the detachable plug portion may become detached during the test. If this occurs the detachable plug portion shall be reassembled with the equipment when the pins are straightened as per (a) and (b) below. (AS/NZS 3112:2017/A1:2021)		
	Three sample which have not been subjected to any previous test are tested to the requirements of clause 2.13.7.1 however, the test is modified for plug portion of equipment with integral pin as follows:		P
	A sample of equipment with integral pins is dropped-	See below	P
	a) 500 times if the mass of the specimen does not exceed 250g. The pins being straightened after 100 drops and at the completion of the test to pass through the appropriate gauge of Figure A1, B1 or F1; and	Weight: 81.0 g. 500 times of falls were conducted Three samples tested. Not damaged. At the completion of the test it can pass through the gauge of Figure A1, B1 or F1, as appropriate.	P
	b) 250 times if the mass of the specimen exceed 250g. The pins being straightened after 25 drops and at the completion of the test to pass through the appropriate gauge of Figure A1, B1 or F1; and		N/A
	Following each test the samples shall comply with item Clause 2.13.7.1.	See below	P
	item (a)-(e) of clause 2.13.7.1: (a): Live parts shall not have become exposed to the standard test finger. (b): For earth pins, the resistance of the plug/socket-outlet circuit shall be such that conformance with Clause 3.14.7 is maintained. (c): Any other function affecting safety shall not be impaired. (d): No live part shall have become detached or loosened, to the extent that a hazardous situation is created (see Clause 2.9). (e): The pins shall be inspected with normal, or corrected to normal, vision. Insulation may be removed if necessary. Pins shall not be broken or show cracking.	No pins broken off, no cracking	P
J4.3.2	Impact test (AS/NZS 3112:2017/A1:2021)		P
	Plug portions and equipment having integral plug portions or detachable plug portions shall withstand lateral impact forces. All samples that were subjected to the tests in Paragraph J4.3.1 shall be tested as follows:		P

AS/NZS 3112: 2017+A1:2021 (Partial)			
Clause	Requirement – Test	Result - Remark	Verdict
	(a) The sample shall be positioned at the centre of a steel plate with a thickness of at least 6 mm. Apertures in the steel plate for the plug pins to pass through shall conform to the corresponding socket Standard. The sample shall be held against the steel plate by clamping all the pins.		P
	(b) Samples shall be subjected to blows, with an impact energy of $1.0 \pm 0.05$ J by any means having the same performance as the spring-operated impact-test apparatus of AS/NZS 3100.		P
	(c) Three blows shall be applied to every point that is most likely to directly or indirectly stress the enclosure joints of the sample		P
	Compliance shall be checked by Paragraph J4.3.3	See below	P
J4.3.3	Specific compliance criteria (AS/NZS 3112:2017/A1:2021)		P
	This Paragraph provides the common compliance assessment criteria for tests specified in Paragraphs J4.3.1 and J4.3.2.		P
	For equipment with an integral plug portion, the assessment(s) shall be made on the complete equipment.		N/A
	For equipment with a detachable plug portion, the assessment(s) shall be conducted on the— (a) assembled equipment with the detachable plug portion connected; and (b) the detachable plug portion after it has been separated from the equipment		P
	Following each test the samples shall comply with Clause 2.13.7.1		P
	(a) Live parts shall not have become exposed to the standard test finger.		P
	(b) For earth pins, the resistance of the plug/socket-outlet circuit shall be such that conformance with Clause 3.14.7 is maintained. The resistance shall not exceed 0.1 $\Omega$ .	No earth pins	N/A
	(c) Any other function affecting safety shall not be impaired		P
	(d) No live part shall have become detached or loosened, to the extent that a hazardous situation is created		P
	(e) The pins shall be inspected with normal, or corrected to normal, vision. Insulation may be removed if necessary. Pins shall not be broken or show cracking.		P
	The detachable plug portion after it has been separated from the equipment.		P
	(a) Live parts shall not have become exposed to the standard test finger.		P
	(b) For earth pins, the resistance of the plug/socket-outlet circuit shall be such that conformance with Clause 3.14.7 is maintained. The resistance shall not exceed 0.1 $\Omega$ .	No earth pins	N/A



AS/NZS 3112: 2017+A1:2021 (Partial)			
Clause	Requirement – Test	Result - Remark	Verdict
	(c) Any other function affecting safety shall not be impaired		P
	(d) No live part shall have become detached or loosened, to the extent that a hazardous situation is created		P
	(e) The pins shall be inspected with normal, or corrected to normal, vision. Insulation may be removed if necessary. Pins shall not be broken or show cracking.		P
	The sample shall conform to the 'Guarding of live parts' requirements of AS/NZS 3100:2015 cl 5.1.		P
	Following each test, no internal conductive material or conductive part shall have become detached or loosened, to the extent that it creates a hazardous situation. The sample shall conform to the 'Separation of live parts from non-current-carrying conductive parts' requirements of AS/NZS 3100. <i>NOTE Specific attention is drawn to the separation of any live parts to exposed metal parts or low voltage to extra low voltage parts.</i>		P
J4.3.4	Pin bending test	See below	P
	The pin of the plug portion of three samples not subjected to any previous tests shall be tested for compliance with the pin bending test of Clause 2.13.7.2 (AS/NZS 3112:2017/A1:2021)	Tested according to cl. 2.13.7.2.	P
Clause 2.13.7.2	All flat-pins of plugs rated up to and including 15A shall be subjected to a pin bending test. Three samples not subject to any previous tests shall be test as following:	New three samples	P
	Pin of assembled plug shall be tested by clamping the plug in a rigid holding block and applying a bending force, as shown in figure 2.8, to the pin under test.		—
	The pin shall be straight at the beginning of the test. If there is any doubt about the straightness of the pin, it shall be checked by the appropriate plug gauge shown in Appendices A, B or F.	Checked with the appropriate plug gauge before conducting test	—
	The portion of application of the force shall be 14±0.5mm from the face of the plug.	The force applied on 14 ± 0.5 mm from the face of the plug	—
	The direction of the force shall be along a line parallel to the face of the plug.	The direction of the force applied along a line parallel to the face of the plug	—

## AS/NZS 3112: 2017+A1:2021 (Partial)

Clause	Requirement – Test	Result - Remark	Verdict
	Active and neutral pins shall be forced towards the centroid of the plug and then back to the starting point. On the first sample plug, any earth pin shall be forced but in one direction only and then back to the starting point. On the second sample plug, any earth pin shall be forced in the opposite direction to that used for testing the first sample plug. On the third sample plug, any earth pin shall be force in the direction that gave the least favourable result during testing of the first two sample plugs.	Tested according to the procedure	—
	The distance moved from the point of application shall be $7.5 \pm 0.3$ mm, and then the pin shall be forced back to the starting point. Any “spring-back” is ignored.	The distance moved from the point of application was $7.5 \pm 0.3$ mm	—
	The travel from the starting point, to the end point (7.5 mm), and back to the starting point is one cycle. (i.e. one cycle is two separate movements)		—
	The speed of deflection shall be maximum of 50 mm/s.	50 mm/s of the speed of deflection	—
	The interval between successive cycles shall be a minimum of 10 s.	10s of the interval	—
	The pins shall be tested for 20 movement cycles.	20 movement cycles	P
	After the tests the pins shall be inspected with normal or corrected to normal vision.		P
	The pin shall not be broken off.	No pins broken off	P
	If in doubt pins shall be disassembled from the plug and any insulation removed.		N/A
J4.4	Temperature rise test	See below	P
	The relevant requirements of clause 2.13.8 are applicable for the temperature rise test, except that the test current shall be that specified in the relevant product standard.	See cl. 2.13.8	P
	The temperature rise of the pins shall not exceed 45K irrespective of the temperature rise of parts specified in end product standards.	See appended table	P
Clause 2.13.8	Plug shall be so constructed that they comply with the following temperature rise test:		P
	a) Non-rewireable plugs are tested as delivered. (specially prepared sample with access to terminals for temperature measurement)	Non-rewireable plug	P
	b) Rewireable plugs are fitted with polyvinyl chloride flexible cord with conductors having the minimum cross-sectional area specified in the manufacturers instructions.	Non-rewireable plug	N/A
	The terminal screws or nuts are tightened with a torque to two-thirds of that specified in test No. 5	No terminal screws or nuts used	N/A

## AS/NZS 3112: 2017+A1:2021 (Partial)

Clause	Requirement – Test	Result - Remark	Verdict
--------	--------------------	-----------------	---------

	To ensure normal cooling of the terminals, the conductors connected to plugs shall have a length of at least 1 m.	See above	N/A
	The plug shall be tested in a draught-free environment at the centre of a plane wooden board, which shall be at least 6 + 2 mm thick, 500 mm wide and 500 mm long with the rear completely enclosed in a wooden mounting enclosure (wall box) of 90 × 60 × 40 mm.		P
	Apertures in the wooden board for the plug pins to pass through are specified in Table 3.1, see Figure 2.9.		P
	Plugs are tested as follows:		P
	The appropriate clamping units with the dimensions specified in Figure 2.10 are fitted on each live pin of the plug, together with the thermocouple.		P
	The screw is then placed approximately in the middle of the bare part of the pin and tightened with a torque of 0.8 Nm. The clamping unit is fitted with PVC-insulated conductors at least 1 m long, having nominal cross-sectional areas as shown in Table 3.3.		P
	Where the conductors pass through the wooden mounting enclosure (wall box) there shall be a complete airtight seal between the conductors and the enclosure.		P
	The plug is inserted into the socket outlet and an alternating current of 1.1 times rated current is passed for 1 h.	Test current: 1.1x0.7A	P
	The temperature of the flexible cord terminal is determined by means of melting particles, colour changing indicators or thermocouples, so chosen and positioned that have negligible effect on the temperature being determined.	K type thermocouple used	P
	Temperature rise of the terminals shall not exceed 45K	See appended table	P

Measurement location	Temperature rise in K	Maximum allow. temp. rise in K	—
Neutral terminal	11.2	45	P
Active terminal	10.5	45	P
Ambient	25.0°C	—	

Notes: Measurement uncertainties were adjudged to be ± 2 °C

J4.5	Securement of pin of the plug portion	See below	P
------	---------------------------------------	-----------	---

## AS/NZS 3112: 2017+A1:2021 (Partial)

Clause	Requirement – Test	Result - Remark	Verdict
	The requirements of clause 2.13.9 are applicable for the securement of pins	See cl. 2.13.9	P
Clause 2.13.9	Securement of pins	See cl. 2.13.9.1 and 2.13.9.2	P
Clause 2.13.9.1	Movement of pins	See below test result	P
	Plug shall be tested for pin movement by clamping the pin or pins not under test in a rigid holding block positioned $5 \pm 0.5$ mm from the plug face and applying a force of $18 \pm 1$ N to the pin under test. The design of the block shall be such that the pin under test shall not come into contact with the block during the test.	A force of $18 \pm 1$ N applied	P
	Except for non-rewireable plugs, the test shall be carried out without a cord attached to the plug, and with the terminal screws loosened sufficiently to allow a $1 \text{ mm}^2$ conductor to be connected.	Non-rewireable plug	N/A
	The plug and test equipment shall be preconditioned at a temperature of $40 \pm 1$ °C for 1 h, without the test force applied. Throughout the test, all parts of the plug test equipment shall be maintained at this temperature.	Preconditioned at a temperature of $40 \pm 1$ °C for 1h	P
	For all plugs, the point of application of the force shall be $14 \pm 0.5$ mm from the face of the plug along the pins, and the direction of the force shall be	Complied	—
	a) in both direction along the line perpendicular to the plane of the pin, and passing through the centre of the pin; and	Both directions tested	P
	b) in that plane in both directions along a line at right angle to that specified in item (a)	Both directions tested	P
	Over a period of 10 s, the force shall be gradually applied to each of the pins in the manner prescribed in item (a) and (b), maintained at its maximum value for 10 s, and then released. The deflection of the pins shall be measured along the line of force relative to the face of the rigid holding block during the period when the force is applied. The maximum deflection shall not exceed 2.0 mm.	Required: 2.0 mm Measured: 0.3 mm	P
	Following the test on all pins of a plug conforming to Figure 2.1, any distortion 5 min. after the completion of the test on the last pin shall be such that it will not prevent the plug from being inserted in the appropriate standard gauges shown in Appendix A, Appendix B and Appendix F without the application of undue force,	After test it can still be inserted in the standard gauge shown in Appendix A, Appendix B or Appendix F, as appropriate, without the application of undue force	P
	For other types of plug, any distortion after 5 min shall be such as will not prevent the plug being inserted into an appropriate socket-outlet without the application of undue force.	All pins of plug confirming to figure 2.1	P

## AS/NZS 3112: 2017+A1:2021 (Partial)

Clause	Requirement – Test	Result - Remark	Verdict
Clause 2.13.9.2	Fixing of pins	See below for test result	P
	A separate sample of a plug, shall be heated to a temperature of $50 \pm 2^\circ\text{C}$ for 1 h and maintained at that temperature during the whole of these tests, including the 5 min. period after removal of the test load.	Heated to a temperature of $50 \pm 2^\circ\text{C}$ for 1h	P
	The plug shall be held firmly in such a manner that there will be no undue squeezing or distortion of the body, and the means of holding shall not assist in maintaining the pins in their original position.	Firmly held without applying undue squeezing or distortion to the body	P
	Each pin, in turn, shall have applied to it a force which, over a period of 10 s, shall be increased steadily to $60 \pm 0.6\text{N}$ and held at this value for 10 min.	A force of $60 \pm 0.6\text{N}$ applied	P
	Two test on each pin shall be conducted, one with the direction of force along the length of the pin toward the body of the plug, and the other with the direction of force along the length of the pin away from the body.	Two tests on each pin were conducted	P
	The attachment of pins shall be considered inadequate if any pin is displaced relative to the adjacent material of the body by more than 2.4 mm at any time during these tests, or if any pin fails to return to within 0.8mm of its nominal length specified in Figure 2.1 within 5 min. of the removal of the test force.	No displacements on any pins of plug were observed	P
J4.6	Tests on the insulation material of insulated pin plug portions.	See below	P
	The requirements of clause 2.13.13 are applicable for insulating material of insulated plug pins.	See cl. 2.13.13	P
Clause 2.13.13	Additional test for plug with insulation pins	See below	P
Clause 2.13.13.1	General		
	The material of the pin-insulation shall be resistant to the stresses to which it may be subjected at the high temperature likely to occur in conditions approaching the bad connection conditions and at low temperature in particular conditions of service.	See below	P
	Compliance shall be checked by the test of Clause 2.13.13.2 to 2.13.13.6	See cl. 2.13.13.2 to 2.13.13.6	P
Clause 2.13.13.2	Pressure test at high temperature	See below	P
	A specimen of one insulated pin only shall be subjected to the following test by means of the apparatus shown in Figure 2.5. This apparatus shall have a round shape with a distance of 6 mm and a thickness of 0.7 mm.	Tested by using of test equipment shown in Figure 2.5	P

## AS/NZS 3112: 2017+A1:2021 (Partial)

Clause	Requirement – Test	Result - Remark	Verdict
	The specimens shall be placed in position as shown in the Figure 2.5 and a force of 2.5N shall be applied through the blade to the specimen.	A force of 2.5 N applied	P
	The apparatus, which the specimen in position, shall be maintained for 2 h in a heating cabinet at a temperature of 160± 5°C. The specimen shall then be removal from the apparatus and, within 10 s, cooled by immersion in cold water.	Tested in a heating cabinet at a temperature of 160 ± 5 °C for 2 h	P
	The thickness of the insulation shall be measured immediately at the point of impression. The thickness within the area of the impression shall not less than 50% of the thickness measured before the test.	After the test, the thickness of sleeve of plug pins (line and neutral pins) remaining at the impression point were reduced approximately 10 % that not more than 50 %. As below plastic were considered: 1. LOTTE CHEMICAL CORPORATION / HN-1064(+) 2. SABIC INNOVATIVE PLASTICS US L L C / 945(GG) 3. SABIC JAPAN L L C / 945(GG) 4. COVESTRO DEUTSCHLAND AG [PC RESINS] / FR6005 + (z) 5. DONGGUAN HUAZHE METALS & PLASTICS LTD / HZ-88	P
	Visual inspection shall be made and no cracks on the insulation material shall be visible with normal, or corrected to normal, vision without additional magnification, and the dimension of the insulating material shall not have changed below the minimum size shown in Figure 2.4	Compliance checked	P
Clause 2.13.13.3	Static damp heat test	See below	P
	An insulated pin plug shall be subjected to two damp heat cycles in accordance with IEC60068-2-30. Db (12+12 h cycle), 95% relative humidity, lower temperature 25±3°C and upper temperature 40°C	Tested in accordance with IEC 60068-2-30	P
	After this treatment and after recovery to room temperature, the specimen shall subjected to:	See below	P
	a) the insulation resistance test in accordance with Clause 2.13.2(e)	500 MΩ	P
	b) high voltage test in accordance with Clause 2.13.3 and;	See cl. 2.13.3	P
	c) abrasion test in accordance with Clause 2.13.13.6	See 2.13.13.6	P
Clause 2.13.13.4	Low temperature test	See below	P

## AS/NZS 3112: 2017+A1:2021 (Partial)

Clause	Requirement – Test	Result - Remark	Verdict
	An insulated pin plug shall be maintained at -15±2°C for at least 24 h and returned to room temperature.	Maintained at -15 ± 2 °C for 24 h	P
	a) the insulation resistance test in accordance with Clause 2.13.2 (e)	500 MΩ	P
	b) high voltage test in accordance with Clause 2.13.3 and;	See cl. 2.13.3	P
	c) abrasion test in accordance with Clause 2.13.13.6	See cl. 2.13.6	P
Clause 2.13.13.5	Impact test at low temperature	See below	P
	A specimen of one insulated pin only shall be subjected to an impact test by means of the apparatus shown in Figure 2.6. The mass of the falling weight shall be 100±1 g,	See below	P
	The apparatus, on a sponge rubber pad 40 mm thick, together with the specimen, shall be maintained at -15±2°C for at least 24 h.	Maintained -15 ± 2 °C for at least 24 hrs	P
	At the end of this period, the specimen shall be placed in position, as shown in Figure 2.6, and the falling weight shall be allowed to fall from a height of 100 mm. Four impacts shall be applied successively to the same specimen, rotating it through 90° between impacts.	Tested by using test equipment shown in Figure 2.6	P
	After the test the specimen shall be allowed to return to room temperature and then examined. No cracks of the insulating material shall be visible with normal, or corrected to normal, vision without additional magnification.	No cracks of the insulating material	P
Clause 2.13.13.6	Abrasion test	See below	P
	An insulated pin of an insulated pin plug shall be subjected to the following test by means of an apparatus as shown in Figure 2.7	See below	P
	The test apparatus comprises a horizontally disposed beam, which shall be pivoted about its center point. A short length of steel wire, 1 mm in diameter and bent into a U-shape, the base of U being straight, shall be rigidly attached, at both ends, to one end of the beam, so that the straight part project below the beam and shall be parallel to the axis of the beam pivot.		P
	The plug shall be held in a suitable clamp in such a position that the straight part of the steel wire rests on the major axis face of the plug pin, at right angles to it. The pin shall slope downwards at an angle of 10° to the horizontal.	Tested at a pin was sloped downwards at an angle of 10° to the horizontal	P
	The beam shall be loaded so that the wire exerts a force of 4 N on the pin	A force of 4N applied	P

## AS/NZS 3112: 2017+A1:2021 (Partial)

Clause	Requirement – Test	Result - Remark	Verdict
	The plug shall be moved backwards and forwards in a horizontal direction in the plane of the axis of the beam, so that the wire rubs along the pin. The length of the pin thus abraded shall be approximately 9 mm, of which approximately 7 mm shall be over the insulation		P
	The number of movements shall be 20,000 (10,000 in each direction) and the rate of operation shall be 30 movements per min.	20,000 of movements with the rate of 30 movements per min	P
	After the test, the pins shall show no damage which may affect safety or impair the further use of the plug, in particular, the insulating sleeve shall not have punctured or rucked up.	No rucked up or punctured of insulating sleeve observed	P
J4.7	Equipment with integral pins intended to be supported by the contacts of a socket-outlet	See below	P
	Unless requirements are contained in the relevant product standard, compliance is checked by inserting the equipment with integral pins, as in normal use, into a flash-mounting combination switch socket-outlet complying with this standard, the socket-outlet being pivoted about a horizontal axis through the centre-lines of the contact apertures at a additional torque, which has to applied to the socket-outlet to maintain the engagement face in the vertical plane, shall not exceed 0.25N.m.	Weight: 109.0 g. The maximum measured torque: 0.050 N·m	P
	Where the equipment with integral pins is fitted with a flexible cord, the test is conducted with the centre-line of the axis of pivot of the socket-outlet located at a point 500 mm above a horizontal surface. The flexible cord is allowed to hang freely from the equipment with that flexible cord in excess of 500 mm resting on the horizontal surface during the test.	Tested as delivered	P
J4.8	Additional requirements for detachable plug portions		N/A
J4.8.1	Access to live parts		N/A
	Detachable plug portion shall be not possible to contact live parts with the small test finger of Figure 13 of IEC 61032.		N/A
	If an opening does not allow entry of the test finger, a force on the test finger in the straight position is increased to 20 N.		N/A
J4.8.2	Construction of detachable contacts where the input current of the equipment exceeds 0.2 A		N/A



## AS/NZS 3112: 2017+A1:2021 (Partial)

Clause	Requirement – Test	Result - Remark	Verdict
	<p>Contacts of the equipment shall be such that they make and maintain, under normal service conditions, satisfactory electrical and mechanical contact with the corresponding contact of the detachable plug portion.</p> <p>The effectiveness of the contacts is checked by inspection and by the plug portion detachment requirements of Paragraph J4.8.3.</p>		N/A
J4.8.3	Plug portion detachment requirements		N/A
	The plug portion and the equipment/adaptor shall be connected and disconnected 50 times (100 strokes).		N/A
	<p>The plug portion shall be securely held in position. A force which, over a period of 10 s, shall be increased steadily to <math>60 \pm 0.6</math> N and held at this value for a further 10 s, shall be applied evenly at the connecting equipment in a direction parallel to the pins. This procedure shall be conducted three times on the same plug portion, at intervals of 5 min, without disturbing the plug portions between tests.</p> <p>During the test period, the plug portion shall not separate from the equipment.</p>		N/A
	The test of AS/NZS 3112 'temperature rise test' for plugs shall be conducted immediately after the above test without disturbing the sample.		N/A
J4.8.4	Resistance of insulating material to heat and fire		N/A
J4.8.4.1	Resistance to heat		N/A
	<p>Subjecting the relevant part to the ball pressure test of IEC 60695-10-2 as specified below.</p> <p>The test is carried out at a temperature of <math>40 \pm 2</math>°C plus the maximum temperature rise determined during the temperature test of Paragraph J4.4, but it shall be at least:</p> <p>(a) <math>75 \pm 2</math>°C, for external parts;</p> <p>(b) <math>125 \pm 2</math>°C, for parts supporting live parts.</p>		N/A
J4.8.4.2	Resistance to fire		N/A
	Plug portions shall comply with the requirements for resistance to fire in accordance with AS/NZS 3100. The glow-wire test temperature 'T' shall be 750°C.		N/A
Appendix K	NON-DETACHABLE PARTS TEST		N/A

AS/NZS 3112: 2017+A1:2021 (Partial)

Clause	Requirement – Test	Result - Remark	Verdict
--------	--------------------	-----------------	---------

Appendix 1: Dimension measurement for 2-pin plug:

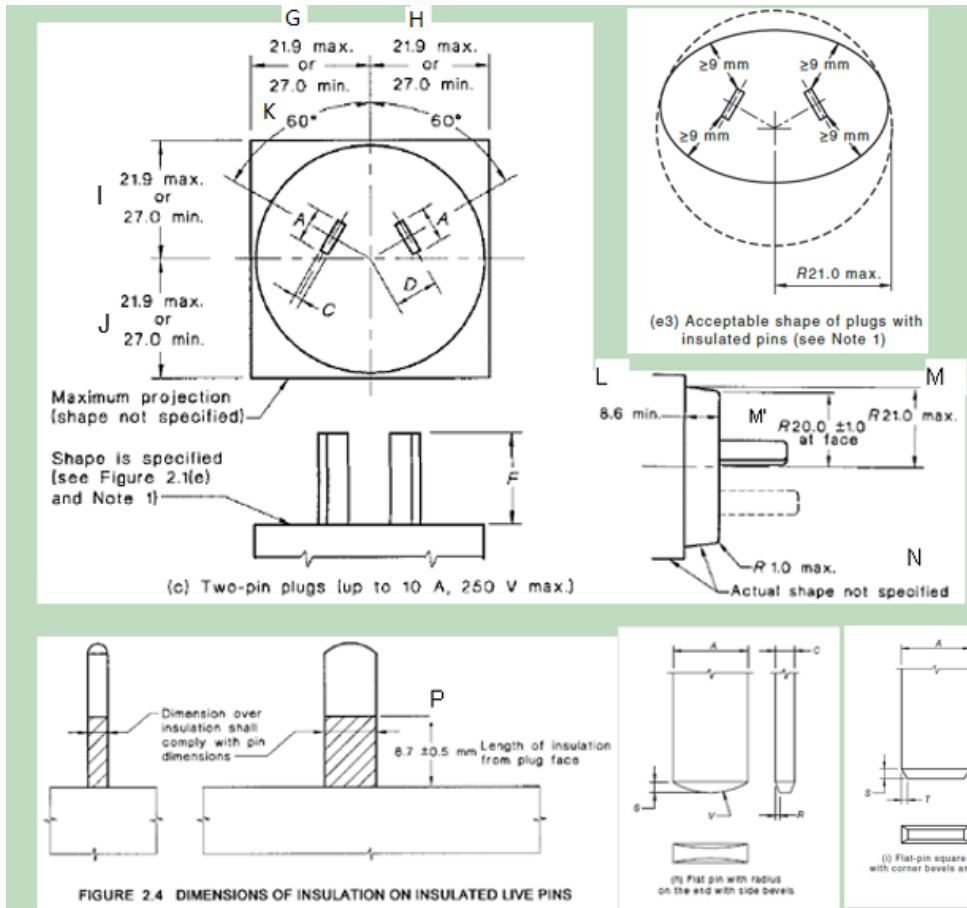

Symbol	Requirement (mm)	Measured (mm)	Symbol	Requirement (mm)	Measured (mm)
A	6.2 – 6.5	6.40	L	≥ 8.6	8.86
C	1.58 – 1.78	1.63	M	R 21.0 max.	20.45
D	7.92	Fit to gauge	M'(only for non-insulated pin type)	R 19.0 – 21.0	--
F	16.66 – 17.46	17.05	N	≤ R 1.0	0.78
G	≤ 21.9 or ≥ 27.0	21.02	P	8.2 – 9.2	9.07
H	≤ 21.9 or ≥ 27.0	21.04	S	0.90±0.10	0.95
I	≤ 21.9 or ≥ 27.0	17.01	V	6.0	Fit to gauge
J	≤ 21.9 or ≥ 27.0	10.98	R	0.35±0.05	0.37
K	60°	60°	T	≥0.60	N/A
The distance between a live pin of any plug and the edge of the moulding of the plug				Min. 9mm	9.24

**Model:**                    MC-681N, MC-682N, MC-683N, MC-685N, MC-686N, MC-687N,  
MC-689N

<b>TABLE: Evaluation of voltage limiting components</b>				--
Component (measured between)	max. voltage (V) (normal operation)		Voltage Limiting Components	Corresponding classification (ES)
	V peak	V d.c.		
Model: MC-682N (Loading: 11Vdc 6.2A)				
T1 (pin 5-6)	82.0	--	--	--
After Q2 pin D-S	--	11.4	--	--
Model: MC-682N (Loading: 20Vdc 3.4A)				
T1 (pin 5-6)	78.0	--	--	--
After Q2 pin D-S	--	21.0	--	--
supplementary information:				
Test voltage 240 Vac, 60 Hz.				

Fault test performed on voltage limiting components	Voltage measured (V) in SELV circuits (V peak or V d.c.)
Q2 pin D-S Short-circuit (MC-682N) (Loading: 11Vdc, 6.2A)	0 (unit shutdown immediately)
Q2 pin D-S Short-circuit (MC-682N) (Loading: 20Vdc, 3.4A)	0 (unit shutdown immediately)
supplementary information:	
Test voltage: 264V Test frequency: 60Hz	

**Model:**                    MC-681N, MC-682N, MC-683N, MC-685N, MC-686N, MC-687N,  
MC-689N

<b>Appended table G.5.3.2</b>	<b>TABLE: transformers (T1)</b>						P
Loc.	Tested insulation	Working voltage peak / V	Working voltage rms / V	Required electric strength	Required clearance / mm	Required creepage distance / mm	Required distance thr. insul.
Primary winding to secondary winding	Reinforced insulation	592	284	4000Vpk	4.5	5.8	0.4mm/2 layers insulation tape/TIW
Core to secondary winding	Reinforced insulation	592	284	4000Vpk	4.5	5.8	0.4mm/2 layers insulation tape/TIW
Loc.	Tested insulation			Test voltage/ V	Measured clearance / mm	Measured creepage dist./ mm	Measure d distance thr. insul. / mm; number of layers
Primary winding to secondary winding pins	Reinforced insulation			4000Vpk	7.1	7.1	TIW
Core to secondary winding pin	Reinforced insulation			4000Vpk	9.2	9.2	TIW
<p>Supplementary information:  Concentric windings on phenolic bobbin. Outer winding is primary, two layers of insulation tape around outer winding. Details see photo document.  The equipment was evaluated for a maximum operating altitude of 5000 m. therefore the requirements of IEC 62368-1 for clearances were considered and the required clearance was multiplied with an altitude correction factor of 1.48.</p>							

**Model:** MC-681N, MC-682N, MC-683N, MC-685N, MC-686N, MC-687N, MC-689N

**Shape structure:**

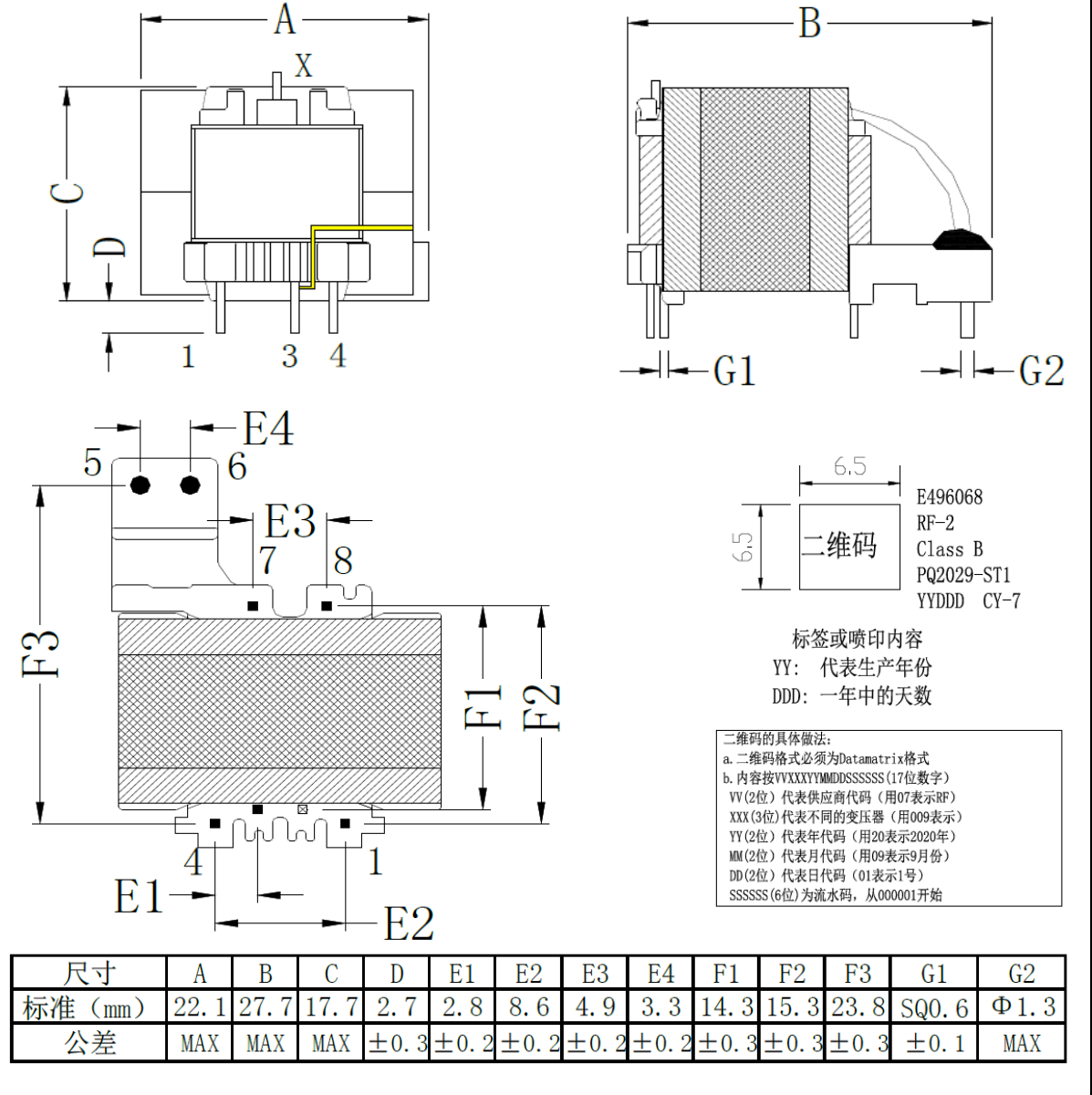

**Model:**                    MC-681N, MC-682N, MC-683N, MC-685N, MC-686N, MC-687N,  
 MC-689N

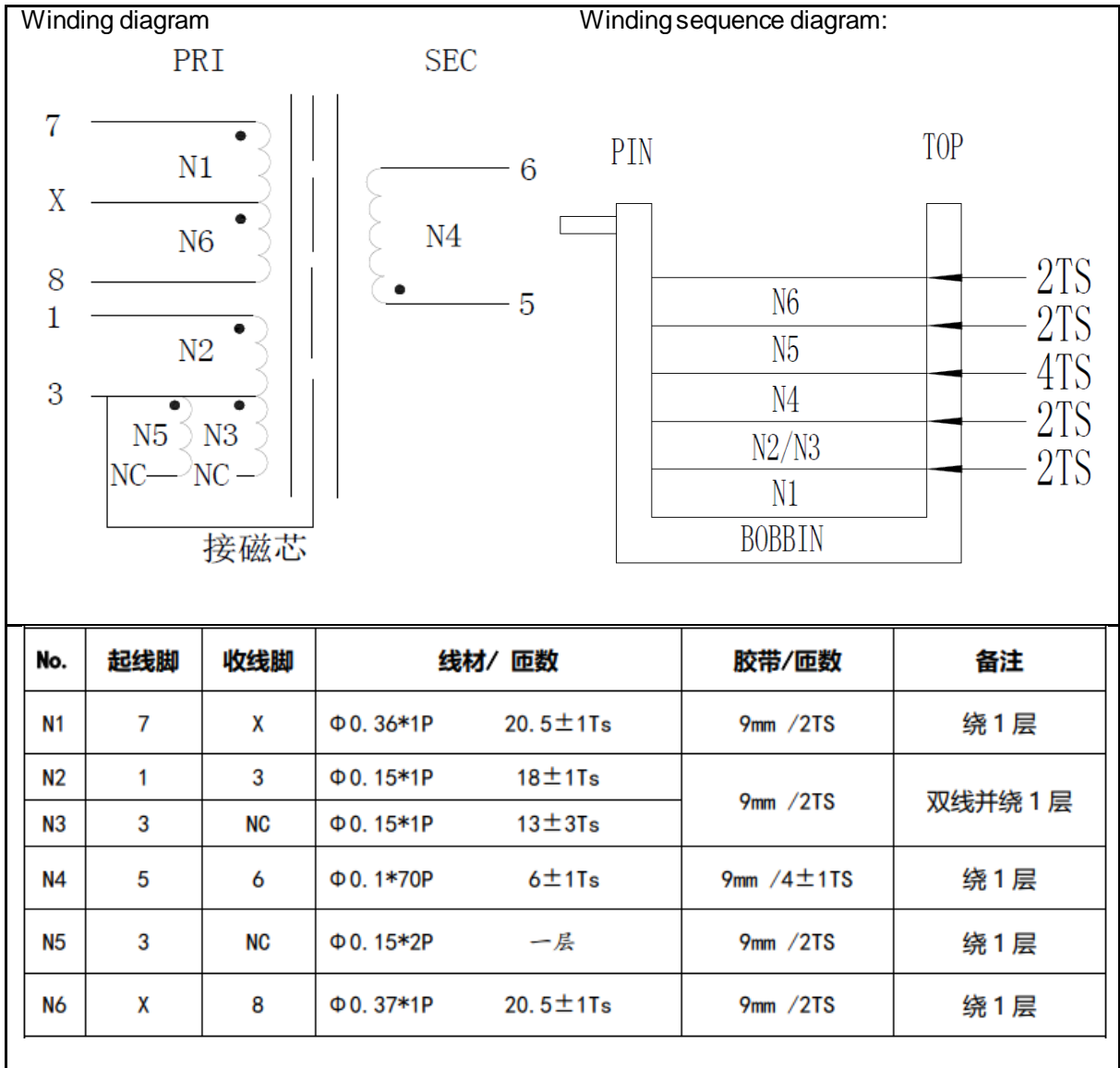

**Model:** MC-681N, MC-682N, MC-683N, MC-685N, MC-686N, MC-687N,  
MC-689N



Picture 1. Overall view (EU plug)



Picture 2. Overall view (EU plug)

**Model:** MC-681N, MC-682N, MC-683N, MC-685N, MC-686N, MC-687N, MC-689N



Picture 3. Internal view (EU plug)



Picture 4. Overall view (AR plug)



**Model:** MC-681N, MC-682N, MC-683N, MC-685N, MC-686N, MC-687N, MC-689N



Picture 5. Overall view (AR plug)

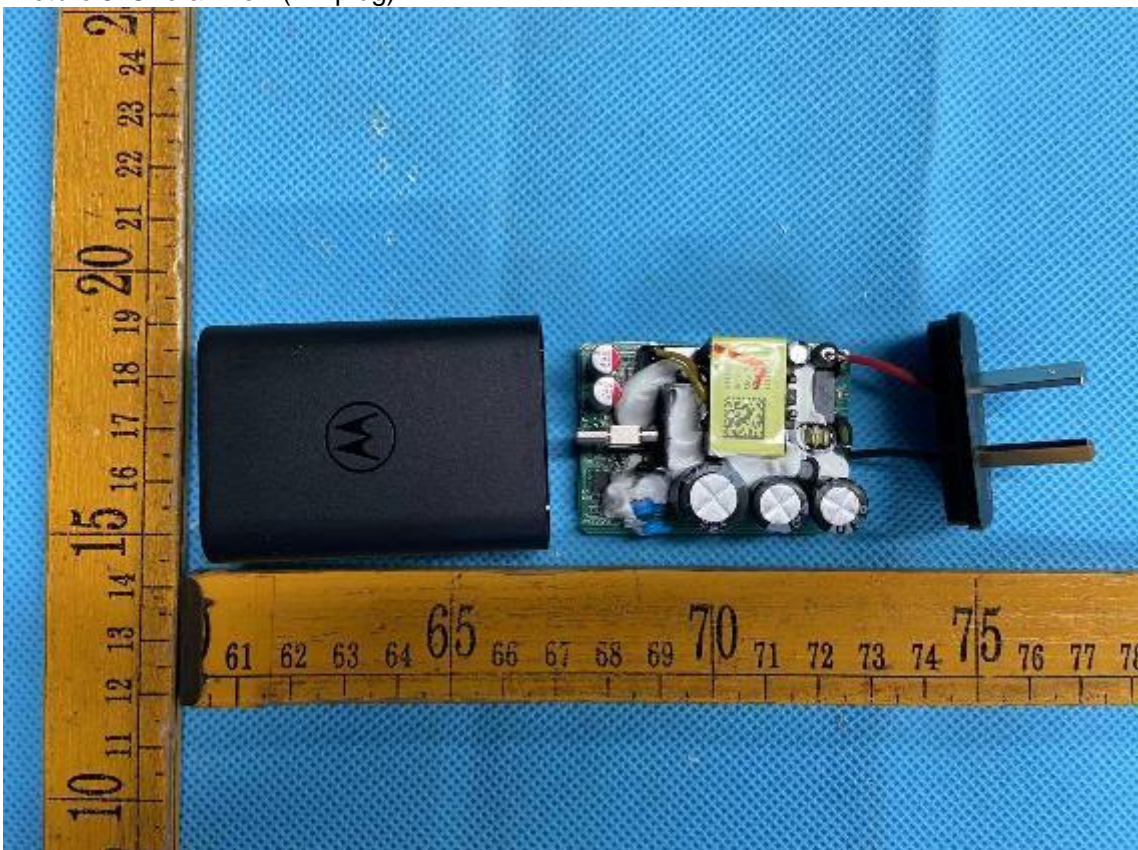

Picture 6. Internal view (AR plug)

**Model:** MC-681N, MC-682N, MC-683N, MC-685N, MC-686N, MC-687N,  
MC-689N



Picture 7. Overall view (USA plug, JP plug)



Picture 8. Overall view (USA plug, JP plug)

**Model:** MC-681N, MC-682N, MC-683N, MC-685N, MC-686N, MC-687N, MC-689N



Picture 9. Internal view (USA plug, JP plug)



Picture 10. Overall view (BR plug)

**Model:** MC-681N, MC-682N, MC-683N, MC-685N, MC-686N, MC-687N, MC-689N



Picture 11. Overall view (BR plug)



Picture 12. Internal view (BR plug)

**Model:** MC-681N, MC-682N, MC-683N, MC-685N, MC-686N, MC-687N,  
MC-689N



Picture 13. Overall view (AU plug)



Picture 14. Overall view (AU plug)

**Model:** MC-681N, MC-682N, MC-683N, MC-685N, MC-686N, MC-687N, MC-689N



Picture 15. Internal view (AU plug)



Picture 16. Overall view (UK plug, Saudi plug)

**Model:** MC-681N, MC-682N, MC-683N, MC-685N, MC-686N, MC-687N, MC-689N



Picture 17. Overall view (UK plug, Saudi plug)



Picture 18. Internal view (UK plug, Saudi plug)

Model: MC-681N, MC-682N, MC-683N, MC-685N, MC-686N, MC-687N,  
MC-689N



Picture 19.PCB trace view



Picture 20.PCB trace view



**Model:** MC-681N, MC-682N, MC-683N, MC-685N, MC-686N, MC-687N, MC-689N

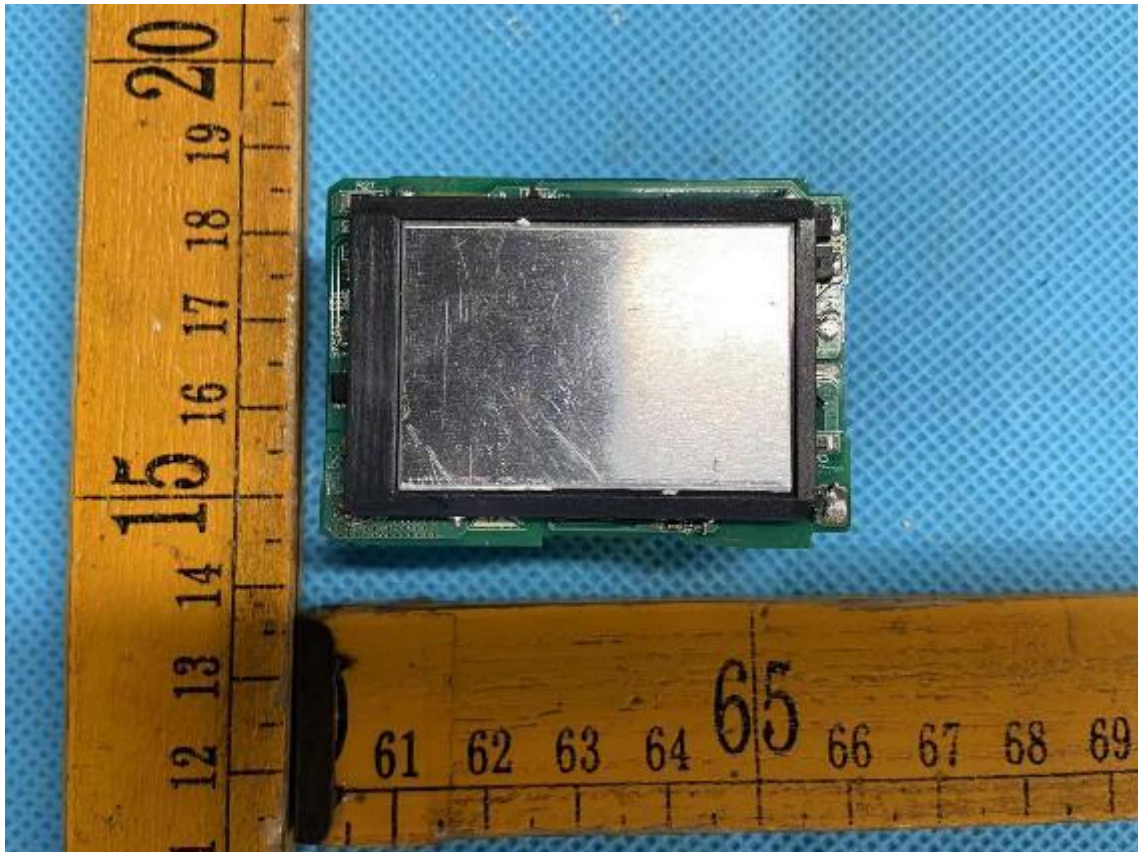

Picture 21.PCB trace view



Picture 22.PCB trace view

Model: MC-681N, MC-682N, MC-683N, MC-685N, MC-686N, MC-687N, MC-689N

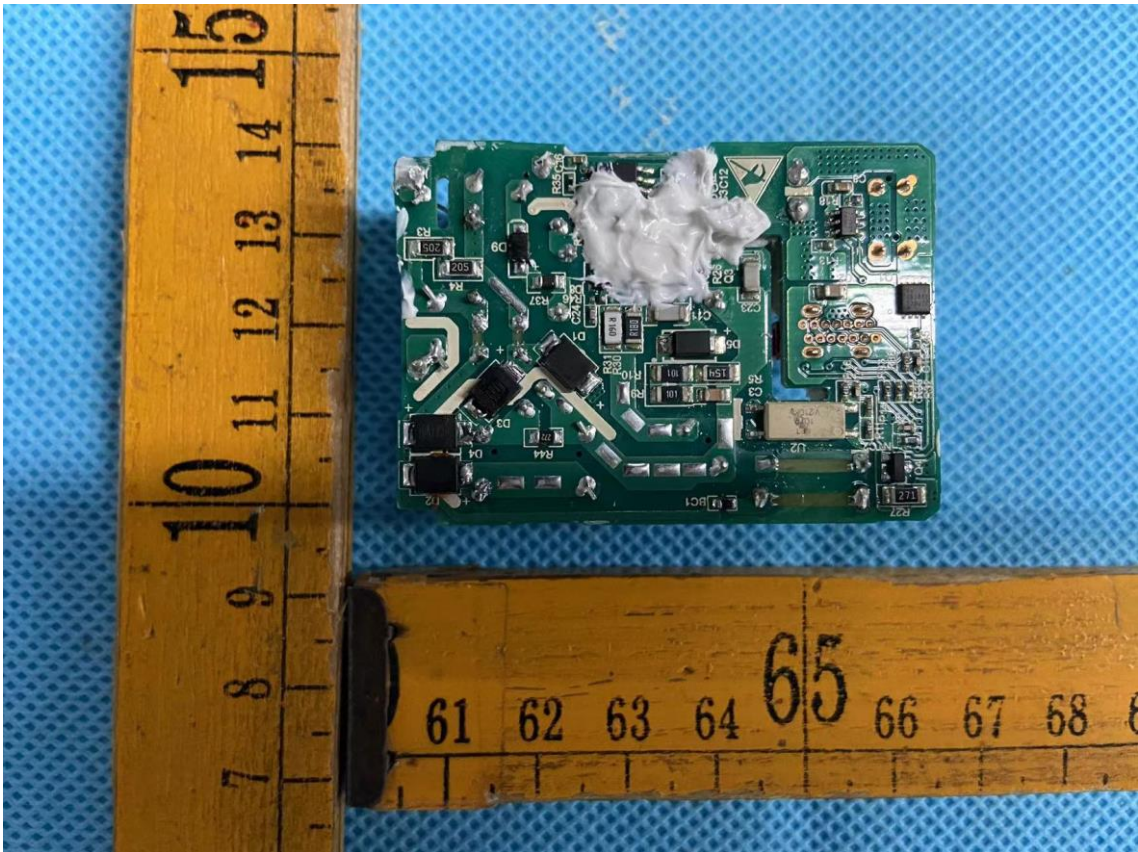

Picture 23.PCB trace view (final with glue)



Picture 24.PCB trace view

**Model:** MC-681N, MC-682N, MC-683N, MC-685N, MC-686N, MC-687N,  
MC-689N



Picture 25. Top View of Transformer

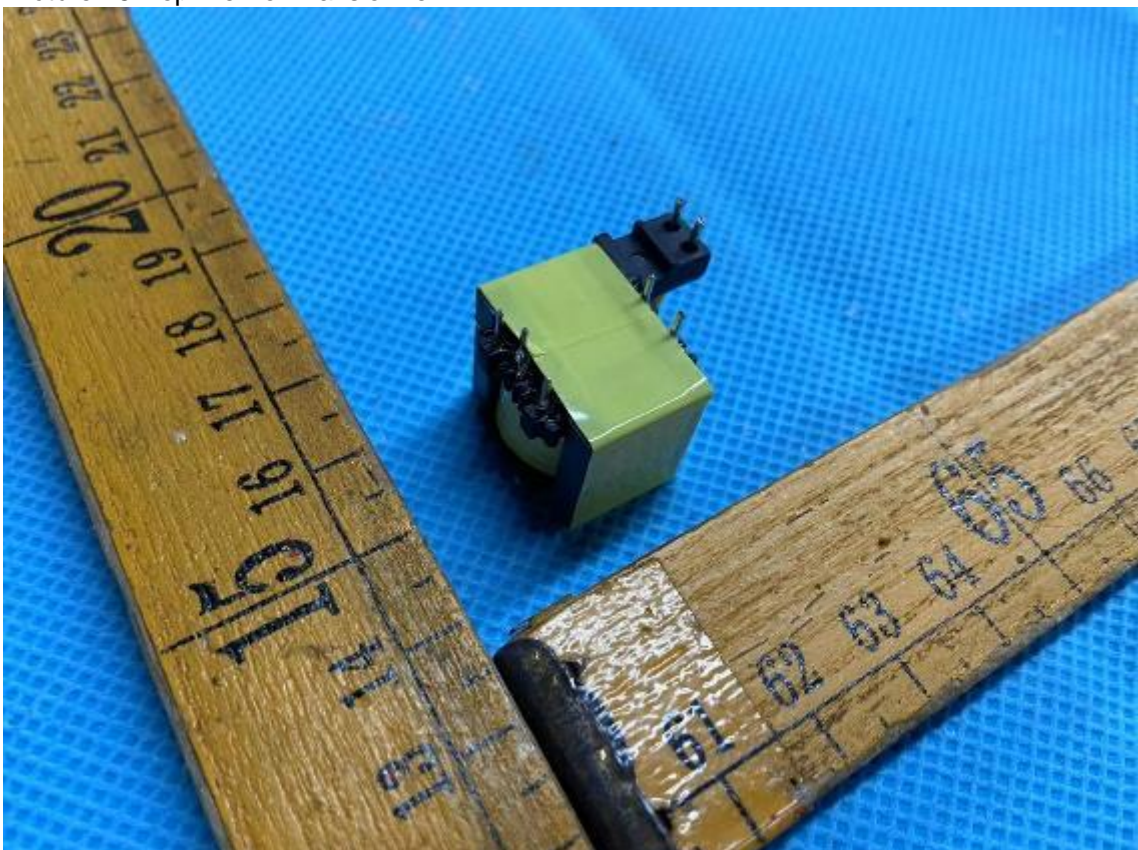

Picture 26. Bottom View of Transformer

**Model:** MC-681N, MC-682N, MC-683N, MC-685N, MC-686N, MC-687N,  
MC-689N



Picture 27. Bottom View of Transformer



Picture 28. Transformer View

**Model:** MC-681N, MC-682N, MC-683N, MC-685N, MC-686N, MC-687N, MC-689N



Picture 29. Transformer



Picture 30. Transformer

**Model:** MC-681N, MC-682N, MC-683N, MC-685N, MC-686N, MC-687N, MC-689N



Picture 31. Transformer



Picture 32. Transformer

**Model:** MC-681N, MC-682N, MC-683N, MC-685N, MC-686N, MC-687N, MC-689N



Picture 33. Transformer



Picture 34. Transformer

**Model:** MC-681N, MC-682N, MC-683N, MC-685N, MC-686N, MC-687N,  
MC-689N



Picture 35. Transformer



Picture 36. Transformer



**Model:** MC-681N, MC-682N, MC-683N, MC-685N, MC-686N, MC-687N, MC-689N



Picture 37. Transformer



Picture 38. Transformer

**Model:** MC-681N, MC-682N, MC-683N, MC-685N, MC-686N, MC-687N,  
MC-689N



Picture 39. Transformer

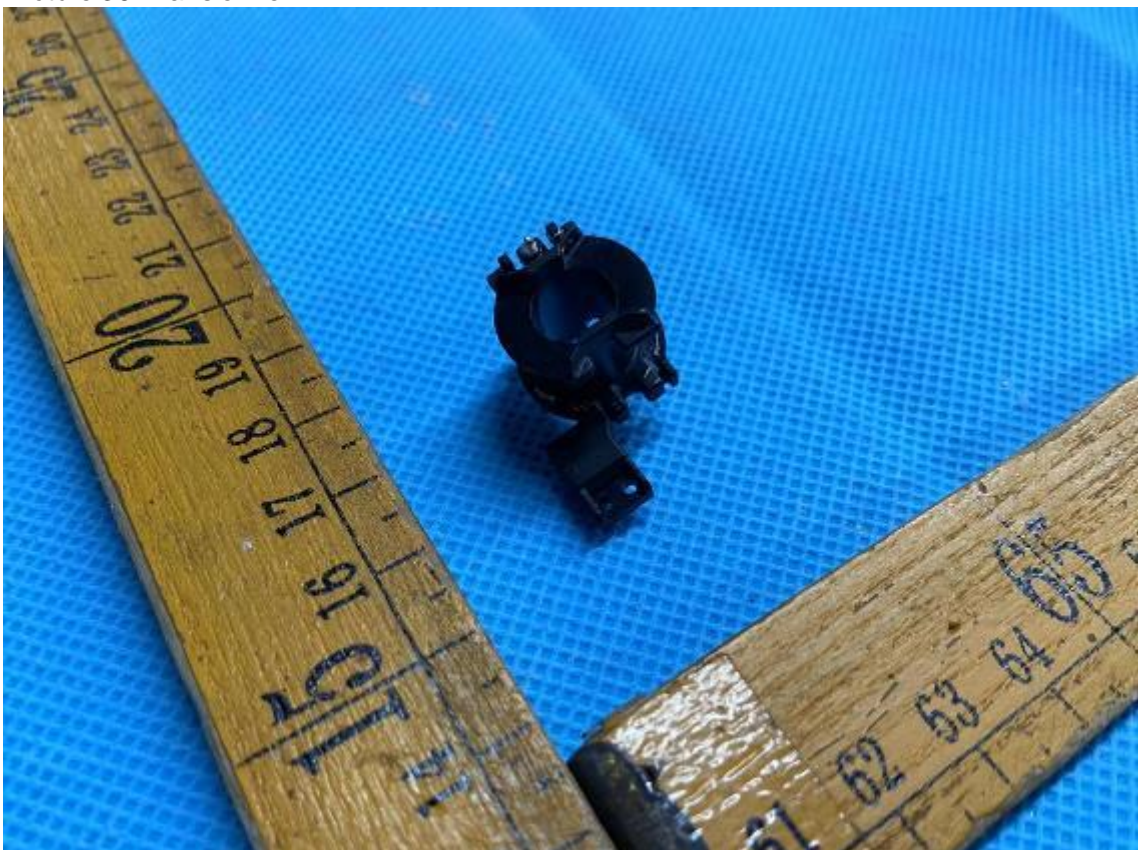

Picture 40. Transformer

IEC 62368-3			
Clause	Requirement - Test	Result	Verdict
<b>4</b>	<b>GENERAL REQUIREMENTS</b>		P
	Equipment serving as a PD or a PSE using voltages at ES1 or ES2,	PSE using voltages at ES1	P
	Equipment used as PSE or PD with proprietary connectors	Used USB port.	N/A
	Equipment where a proprietary protocol is used to enable the power transfer		N/A
<b>5</b>	<b>POWER TRANSFER USING ES1 OR ES2 VOLTAGES</b>		P
<b>5.1</b>	<b>General requirements</b>		P
	Maximum rated output voltage of PSE (V).....:	See appended table 5.1	—
	under conditions of no load (V).....:		—
	normal load (V) .....		—
	maximum rated load (V) .....		—
	Rated limits of intended communication systems:	USB power delivery up to 20V max.	P
	PD or PSE have the capability to both provide power and receive power	No such equipment.	N/A
<b>5.2</b>	<b>Electrical-caused injury, electrical sources and safeguards</b>		P
	For a PSE classified as ES1 and ES2, the requirements of IEC 62368-1 clause 5.2 apply.		P
<b>5.3</b>	<b>Electrical-caused fire, power sources and safeguards</b>		P
5.3.1	Output power reduces the likelihood of ignition.	Not such interconnection to building wiring	N/A
	Output current does not cause damage to communication cables, building wiring, and other devices including PD.		N/A
	PSE circuits comply with IEC 62368 1, Annex Q.1 requirements for limited power source (LPS).		N/A
	Interconnection of PSE circuits to other devices for DC power transfer via building wiring		N/A
	PSE maximum continuous current (A) .....		—
	Minimum wire gauge specified in the equipment installation instruction (mm <sup>2</sup> or AWG) .....		—
	Current limits of minimum wire gauge (A) .....		—
	PD receives multiple PSE power inputs. PD implements power limiting in accordance with PS2 or IEC 62368-1, Annex Q	See appended table 5.3.1	N/A

IEC 62368-3			
Clause	Requirement - Test	Result	Verdict
	PSE connected to external paired conductor cable having a minimum wire diameter of 0.4 mm (IEC 62368-1:2014, Table 14, ID 1 and 2 IEC 62368-1:2018, Table 13, ID 1 and 2)		N/A
	Current limited to not more than 1.3 A .....		—
5.3.2	DC power transfer interconnection to other equipment, where it is unknown that attached devices are likely to comply with IEC 62368-1, PSE circuit shall comply with requirements of IEC 62368-1 for PS2 or Clause Q.1	The USB port comply with requirements of IEC 62368-1 for PS2 and Clause Q.1, detail see IEC 62368-1 test report.	P
	Available output current under abnormal operating conditions and single fault conditions in the PSE does not exceed the specified fault current rating in power delivery specification.	Complied, see below.	P
	Fault current rating in power delivery specification (A).....	USB-C Rating Current 6.2A max.	—
	Available output current under abnormal operating conditions and single fault conditions in the PSE (A).....	Max. 6.49A	—
	No prescribed maximum fault current specified for standardized interface. Available current not exceeding:	See below	P
	8.0 A under any circumstances	Max. 6.49A	P
	Circuits > 2 A, 130% for more than 5 s .....	Complied	P
	Circuits ≤ 2 A, 150% for more than 5 s:.....		N/A
<b>5.4</b>	<b>Safeguards to protect against a single fault condition in the PSE</b>		P
5.4.1	Requirement for the PSE	See appended table 5.4.1	P
	PSE with a single output voltage .....		N/A
	Nominal rated output voltage (V) .....		—
	Single fault conditions output voltage (V) .....		—
	ES2 limit (DC 120V, 50V RMS, 70.7 V peak)		N/A

<b>IEC 62368-3</b>			
Clause	Requirement - Test	Result	Verdict
	PSE delivering a range of output voltages via negotiation with the PD .....	5V/9V/15V/20V/11V	P
	Single fault conditions output voltage (V) .....	See appended table 5.4.1	—
	Negotiated > 5 V, output 130% (min. 7.5 V) .....	See appended table 5.4.1	P
	Negotiated ≤ 5 V, output 150% .....	See appended table 5.4.1	P
5.4.2	Requirement for the PD	PSE	N/A
	Nominal rated input voltage (V) .....		—
	Nominal > 5 V, supplied with 130% (min. 7.5 V) :		N/A
	Nominal ≤ 5 V supplied with 150% .....		N/A
	Any consequential failure of components in the PD .....		N/A

IEC 62368-3			
Clause	Requirement - Test	Result	Verdict
<b>6</b>	<b>POWER TRANSFER USING RFT</b>		N/A
<b>6.1</b>	<b>General requirements</b>		N/A
	Access to RFT circuit conductors is restricted to a skilled person .....		N/A
	Access by an instructed person is restricted in accordance with IEC 62368-1, clause 5.3.2.1 and 5.3.2.2.....		N/A
<b>6.2</b>	<b>Connection to ICT networks</b>		N/A
	RFT circuit directly connected to an ICT network:		N/A
<b>6.3</b>	<b>Electrically caused injury</b>		N/A
6.3.1.1.1	The current limits in 6.3.1.1.2 to 6.3.1.1.4 are inherently met.	See appended table 6.3.1.1	N/A
	The RFT-C circuit has a monitoring and control device that maintains the required current limits		N/A
6.3.1.1.2	Limits under normal operating conditions		N/A
	a) steady state current from supply equipment into ICT network under any load condition (mA) .....		N/A
	b) using a resistor of $2\,000\ \Omega \pm 2\%$ , max. steady state current from one conductor of equipment through ICT network to earth (mA).....		N/A
	c) RFT-C circuit is limited to voltage rating of ICT network wiring, if this voltage is known (V).....		N/A
	d) RFT-C circuit voltage rating of insulation between conductors and from any conductor to earth is coordinated with max. RFT-C circuit supply equipment voltage (V) .....		N/A
6.3.1.1.3	Current measured under single fault conditions did not exceed the line-to-earth and line-to-line limits in Figure 1	See appended table 6.3.1.1	N/A
6.3.1.1.4	Current limits with one RFT-C conductor accidentally earthed, between the other conductor and earth measured through a $2\,000\ \Omega \pm 2\%$ resistor, under any external load condition .....		N/A
	Current not exceeding line-to-earth limits in Figure 1 with a limit of 25 mA after 10 s .....		N/A
	Open circuit voltage between other conductor and earth not exceeding maximum RFT-C circuit voltage determined in 6.3.1.1.2 c) and 6.3.1.1.2 d), after 2 s .....		N/A

IEC 62368-3			
Clause	Requirement - Test	Result	Verdict
6.3.1.2	RFT-V circuit limits	See appended table 6.3.1.2	N/A
6.3.1.2.1	Limits under normal operating conditions		N/A
	Steady state open circuit voltage between earth and each RFT-V circuit conductor that normally connects to an ICT network, not exceeding (V) - 140 V DC .....: - 200 V DC with monitoring and control device in accordance with 6.3.1.2.3 .....		N/A
	Voltage rating of insulation of RFT-V circuit receiving power via ICT network is suitable for - 400 V between conductors and - 200 V from any conductor to earth .....		N/A
6.3.1.2.2	Voltage limits within RFT-V circuit supply equipment under single fault conditions (see IEC 62368-1, clause B.4)		N/A
	with any conductor of RFT-V circuit that normally connects to ICT network being earthed (V).....:		—
	without any conductor of RFT-V circuit that normally connects to ICT network being earthed (V) .....		—
	Not exceeding Figure 2 limits during first 200 ms, measured across a $5\,000\ \Omega \pm 2\%$ resistor with all load circuits disconnected		N/A
	Not exceeding 6.3.1.2.1 limits after first 200 ms		N/A
6.3.1.2.3	Voltage limits with one RFT-V conductor earthed, between the other conductor and earth:		N/A
	Not exceeding maximum RFT-V circuit supply voltage after 200 ms (V).....:		N/A
	For RFT-V circuits with normal open circuit voltage exceeding 140 V DC, current between the other conductor and earth not exceeding Figure 1 line-to-earth limits, measured through a $2\,000\ \Omega \pm 2\%$ resistor, under any external load condition .....		N/A
	This current not exceeding 10 mA DC after 10 s :		N/A
6.3.2	Accessibility to electrical energy sources and safeguards (See also IEC 62368-1, 5.3.2)		N/A
6.3.2.1	Accessibility for an ordinary person		N/A
	Adequate protection against contact with RFT circuits bare parts for all positions of the equipment wired and operated as in normal use.		N/A
	Not accessible: bare parts at ES3; and an ES3 basic safeguard		N/A

IEC 62368-3			
Clause	Requirement - Test	Result	Verdict
	Not accessible: bare parts at ES2, except for pins of connectors. However, such pins are not accessible under normal operating conditions by IEC 62368-1, Figure V.3 blunt probe		N/A
	Protection achieved by insulation, guarding (electrical enclosure), interlocks :	See appended table 4.1.2	N/A
6.3.2.2	Accessibility for an instructed person (See also IEC 62368-1, clause 4.3.3)		N/A
	Contact is possible with RFT circuit bare parts by the IEC 62368-1, Figure V.3 blunt probe		N/A
	RFT circuit bare parts so located or guarded that unintentional contact is unlikely.		N/A
6.3.2.3	Accessibility for a skilled person (See also IEC 62368-1, clause 4.3.4 and 5.3)		N/A
	RFT circuits bare parts located or guarded so that accidental shorting to ES1 or ES2 parts is unlikely		N/A
	Required guards easily removable and replaceable if necessary for servicing.		N/A
6.3.3	Safeguards		N/A
6.3.3.1	RFT circuits separated from other circuits and parts.....:		N/A
	- from other RFT circuits by functional insulation. If shorted, neither circuit exceeds 6.3.1.1 and 6.3.1.2 limits		N/A
	- from other RFT circuits separated as if one was at ES3		N/A
	- from earthed accessible parts, earthed ES1 circuits and earthed ES2 circuits by basic insulation		N/A
	- from unearthed accessible parts, ES1, ES2 and ES3 circuits by one or both: <ul style="list-style-type: none"> <li>• double insulation or reinforced insulation;</li> <li>• basic insulation, together with a conductive screen as protective bonding conductor.</li> </ul>		N/A
6.3.3.2	Interconnection of equipment		N/A
6.3.3.2.1	General requirements.....:		N/A
	Interconnecting cable containing more than one type of circuit .....		N/A
6.3.3.2.2	Interconnection between RFT circuits		N/A
	RFT-C circuits in supply equipment are connected to RFT-C circuits in other equipment .....		N/A
	RFT-V circuits in supply equipment are connected to RFT-V circuits in other equipment .....		N/A
6.3.4	Installation instructions for equipment using an RFT circuit do specify:		N/A
6.3.4 a)	RFT circuit voltage (V).....:		N/A



<b>IEC 62368-3</b>			
Clause	Requirement - Test	Result	Verdict
6.3.4 b)	EUT effective capacitance between connection points		N/A
	1) for the ICT network conductors (nF) .....		—
	2) for ICT network one conductor and earth (nF):		—
6.3.4 c)	A system assessment shall be carried out at the time of installation, to ensure:		N/A
	Effective capacitance of the total system, including the capacitance of the EUT, does not exceed the values specified in Figure 3 .....		N/A
6.3.4 d)	Checking is done that the voltage rating of ICT network wiring is adequate for normal RFT circuit voltage, together with superimposed transients.:		N/A
6.3.4 e)	Checking is done that circuits to be connected together are either all RFT-C circuits or all RFT-V circuits.....		N/A
6.3.4 f)	Where an RFT circuit is directly connected to an ICT network, that the building cabling termination records are updated to indicate which terminals are used for an RFT circuit .....		N/A
<b>6.4</b>	<b>Electrically caused fire</b>		N/A
6.4.1	Classification of RFT power sources		N/A
6.4.1.1	RFT-C power source is a PS2 circuit (See IEC 62368-1, clause 6.2.2.5 or 6.2.2.6) .....		N/A
	RFT-C circuit limited by maximum current (60 mA) and maximum voltage (usually < 800 V).		N/A
	RFT-C circuits comply with requirements of 6.4.2.		N/A
6.4.1.2	RFT-V power source is a PS2 circuit (See IEC 62368-1, clause 6.2.2.5).....		N/A
	RFT-V circuits comply with requirements of 6.4.2.		N/A
6.4.2	Fire protection requirements		N/A
	RFT circuit power in accordance with Table 1 ...:		N/A
	Output voltage (V) .....		—
	Maximum current (A) .....		—
	Maximum Power (W) .....		—
	Steady state current that can be supplied to ICT network complies with IEC 62368-1:2014, 6.5.3 IEC 62368-1:2018, 6.5.2 .....		N/A

IEC 62368-3					
Clause	Requirement - Test	Result			Verdict
<b>5.1</b>	<b>Table: Power transfer using ES1 or ES2 voltages. General requirements</b>				
Output Connector	Components	Output voltage V dc)			
		No load	Normal load	Max. rated road	Limits
USB /5V	Normal	5.03	5.03 Max.	4.83	5.25V
USB /9V	Normal	9.00	9.00 Max.	8.73	20V
USB /15V	Normal	15.00	15.00 Max.	14.70	20V
USB /20V	Normal	19.58	19.58 Max.	19.17	20V
USB /11V	Normal	10.76	10.76 Max.	10.03	20V
Supplementary Information: For USB ports, applied normal load equal to max. rated load.					

<b>5.3.2</b>	<b>TABLE: DC power transfer interconnection to other equipment</b>					P
Note: Measured each port with maximum attainable current:						
Output Circuit	Components	Fault current rating (A)	Any circumstance (A)		More than 5 s (A)	
			Meas.	Limit	Meas.	Limit <sup>1)</sup>
USB-C (Loading: 5VDC, 3A)	Normal operation	N/A	3.15	8	3.15	8A
USB-C (Loading: 5VDC, 3A)	S-C U2 pin 1-2	N/A	0	8	0	8A
USB-C (Loading: 9VDC, 3A)	Normal operation	N/A	3.15	8	3.15	8A
USB-C (Loading: 9VDC, 3A)	S-C U2 pin 1-2	N/A	0	8	0	8A
USB-C (Loading: 15VDC, 3A)	Normal operation	N/A	3.15	8	3.15	8A
USB-C (Loading: 15VDC, 3A)	S-C U2 pin 1-2	N/A	0	8	0	8A
USB-C (Loading: 20VDC, 3.4A)	Normal operation	N/A	3.61	8	3.61	8A
USB-C (Loading: 20VDC, 3.4A)	S-C U2 pin 1-2	N/A	0	8	0	8A

IEC 62368-3						
Clause	Requirement - Test			Result		Verdict
USB-C (Loading: 11VDC, 6.2A)	Normal operation	N/A	6.49	8	6.49	8A
USB-C (Loading: 11VDC, 6.2A)	S-C U2 pin 1-2	N/A	0	8	0	8A
Supplementary Information: Fault current rating: > 2 A, limit 130%, ≤ 2 A, limit 150% Fault conditions tested: SC=Short circuit, OC=Open circuit						

5.4.1	TABLE: Requirement for the PSE					P
Note: Measured U fault (V) with all load circuits disconnected:						
Output Circuit	Components	U nominal rated (V)	U fault (V)		Fault conditions tested	
			Meas.	Limit		
USB-C (Loading: 5VDC, 3A)	--	5.0	5.03	7.5	Overload	
USB-C (Loading: 5VDC, 3A)	S-C U2 pin 1-2	5.0	0	7.5	Short circuit	
USB-C (Loading: 9VDC, 3A)	--	9.0	9.00	11.7	Overload	
USB-C (Loading: 9VDC, 3A)	S-C U2 pin 1-2	9.0	0	11.7	Short circuit	
USB-C (Loading: 15VDC, 3A)	--	15.0	15.00	19.5	Overload	
USB-C (Loading: 15VDC, 3A)	S-C U2 pin 1-2	15.0	0	19.5	Short circuit	
USB-C (Loading: 20VDC, 3.4A)	--	20.0	19.58	26.0	Overload	
USB-C (Loading: 20VDC, 3.4A)	S-C U2 pin 1-2	20.0	0	26.0	Short circuit	

IEC 62368-3					
Clause	Requirement - Test	Result			Verdict
USB-C (Loading: 11VDC, 6.2A)	--	11.0	10.76	14.3	Overload
USB-C (Loading: 11VDC, 6.2A)	S-C U2 pin 1-2	11.0	0	14.3	Short circuit
Supplementary Information: Fault conditions tested: SC=Short circuit, OC=Open circuit					

5.4.2	TABLE: Requirement for the PD					N/A
Note: Measured U input at PSE with all other load circuits disconnected:						
Input Circuit	Components	U nominal rated (V)	U input (V)		Observation	
			Meas.	Limit	Component	Hazard
Supplementary Information: Conditions tested: PD supplied with voltage above nominal rated input voltage. Nominal > 5 V, supplied with 130% (min. 7.5 V) Nominal ≤ 5 V supplied with 150%						

IEC 62368-3							
Clause	Requirement - Test			Result			Verdict
<b>6.3.1.1</b>	<b>TABLE: RFT-C circuit limits</b>						N/A
No.	Supply Voltage	Location (e.g. circuit designation)	Test conditions	Parameters			Observation
				U (V DC)	I (mA DC)	limit	
1			Normal load			60 mA	
			Abnormal load			60 mA	
			To earth			2 mA	
			Single fault			60 mA	
			Single fault – to earth			25 mA	
2			Normal load			60 mA	
			Abnormal load			60 mA	
			To earth			2 mA	
			Single fault –			60 mA	
			Single fault – to earth			25 mA	
Supplementary information:							
1) Current flow from the RFT-C CIRCUIT supply equipment into the TELECOMMUNICATION NETWORK							
2) Current flow from one conductor of the RFT-C CIRCUIT supply equipment through the TELECOMMUNICATION NETWORK to earth. Use of a resistor of 2000 $\Omega$ $\pm$ 2 %							

IEC 62368-3			
Clause	Requirement - Test	Result	Verdict

6.3.1.2		TABLE: RFT-V circuit limits					N/A
No.	Supply Voltage	Location (e.g. circuit designation)	Test conditions	Parameters			Observation
				U (V DC)	I (mA DC)	limit	
1			Open circuit			140 V	
			Open circuit, monitored			200 V	
			Single fault – < 200 ms			Figure 2	
			Single fault – > 200 ms			140 V	
			Single fault – > 200 ms, monitored			200 V	
			Conductor earthed > 200 ms			Figure 1	
			Conductor earthed > 10 s			10 mA	
2			Open circuit			140 V	
			Open circuit, monitored			200 V	
			Single fault – < 200 ms			Figure 2	
			Single fault – > 200 ms			140 V	
			Single fault – > 200 ms, monitored			200 V	
			Conductor earthed > 200 ms			Figure 1	
			Conductor earthed > 10 s			10 mA	
Test Conditions: Normal – Abnormal - Supplementary information: SC=Short Circuit, OC=Open Circuit							

IEC 62368-3			
Clause	Requirement - Test	Result	Verdict

4.1.2	TABLE: List of critical components					N/A
Object / part No.	Manufacturer/ trademark	Type / model	Technical data	Standard	Mark(s) of conformity <sup>1</sup>	
- Description <sup>2)</sup> :						
- Description <sup>2)</sup> :						
- Description <sup>2)</sup> :						

Supplementary information: See referred IEC 62368-1 test report.

<sup>1)</sup> Provided evidence ensures the agreed level of compliance. See OD-2039.

<sup>2)</sup> Description line content is optional. Main line description needs to clearly detail the component used for testing