

**(D)** *Montageanleitung*

**(NL)** *Handleiding voor de montage*

**(TR)** *Montaj talimatı*

**(FR)** *Notice de montage*

**(CZ)** *Montážní návod*

**(HU)** *Szerelési útmutató*

**(GB)** *Assembly instructions*

**(PL)** *Instrukcja montażu*

**(RU)** *Инструкция по монтажу*

**(IT)** *Istruzioni di montaggio*

**(SK)** *Návod na montáž*

**(RO)** *Instrucțiuni de montaj*

Name • Nom • Nome • Naam • Nazwa • Jméno •  
Názov • Név • Denumire • Isim • Название

Nr. • No. • N° • Номер • Č • Sz

Typ • Type • Tip • Típus • Tipo • Тип

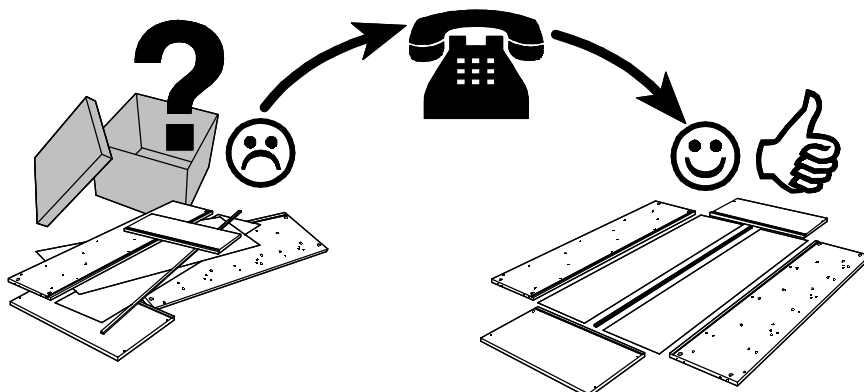
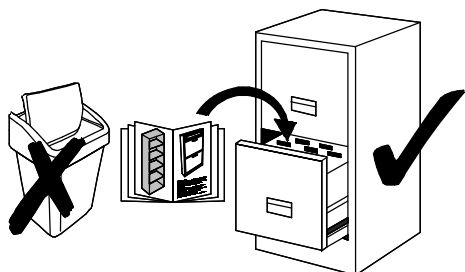

<b>A</b>	8 x	<b>C</b>	2 x	<b>Ce</b>	2 x	<b>Dd</b>	2 x	<b>Ea</b>	4 x	<b>Fb</b>	1 x
Ø8 x 35		2 mm		fk.9		M4 x 20		Ø3,5 x 15		3 mm	
<b>G</b>	4 x	<b>Ga</b>	4 x	<b>Hc</b>	4 x	<b>I</b>	25 x	<b>lb</b>	1 x	<b>Lk</b>	1 x
L - 34		Ø15 x 11		Ø5 x 50		Ø1,2 x 20		45 x 20 x 16		2 set	
<b>N</b>	8 x	<b>No</b>	1 x								
Ø5 / Ø5		131 x 20									

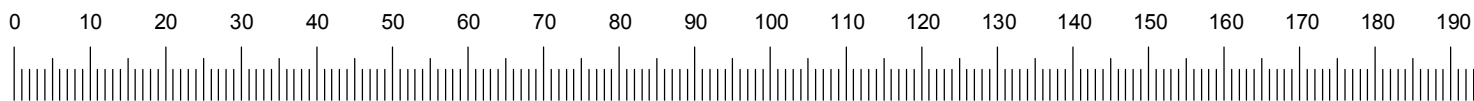
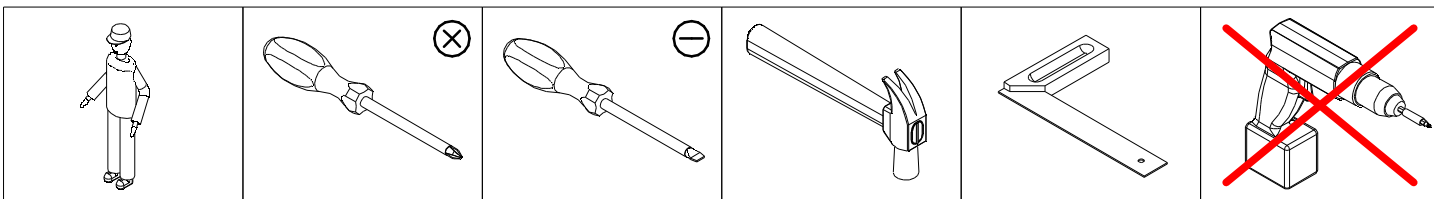

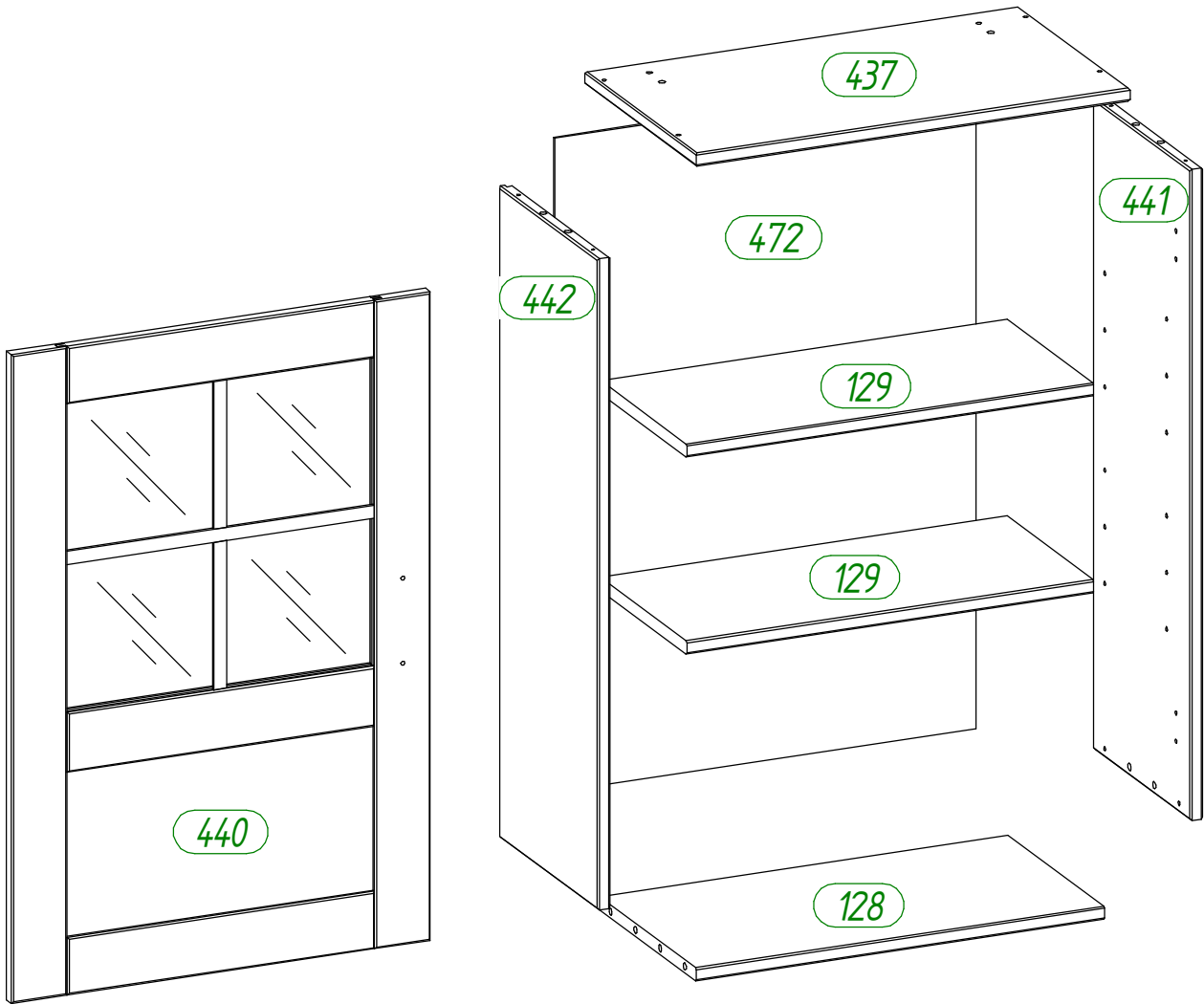

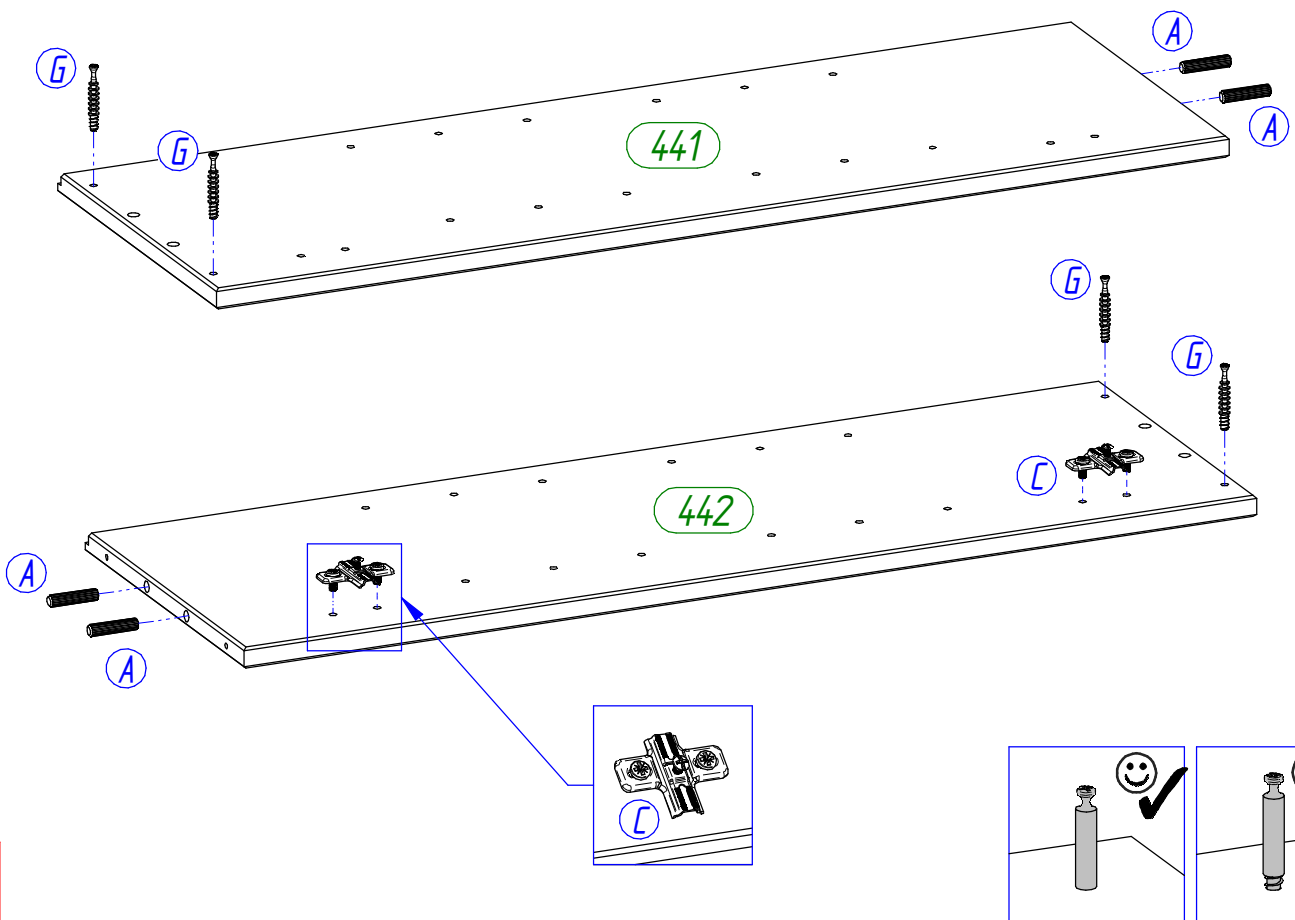
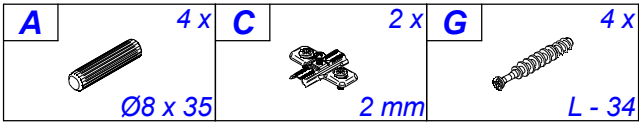
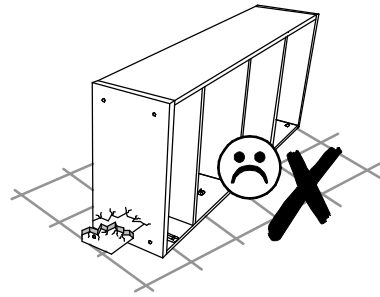
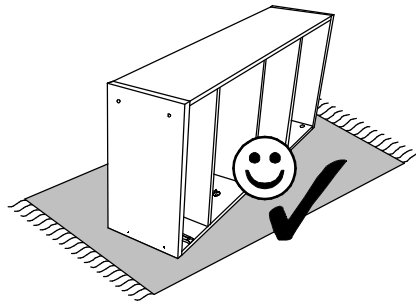

1

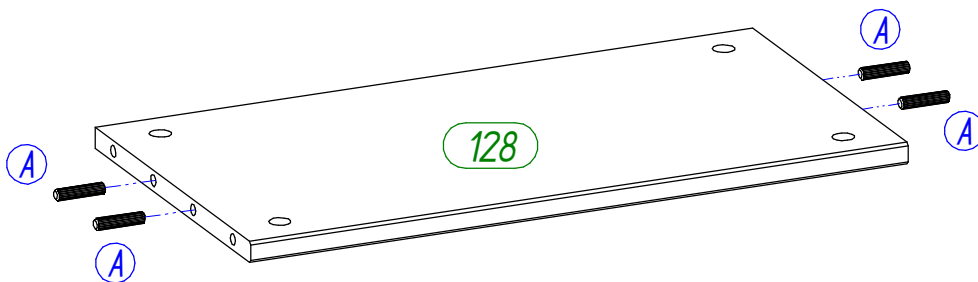
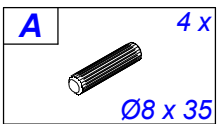

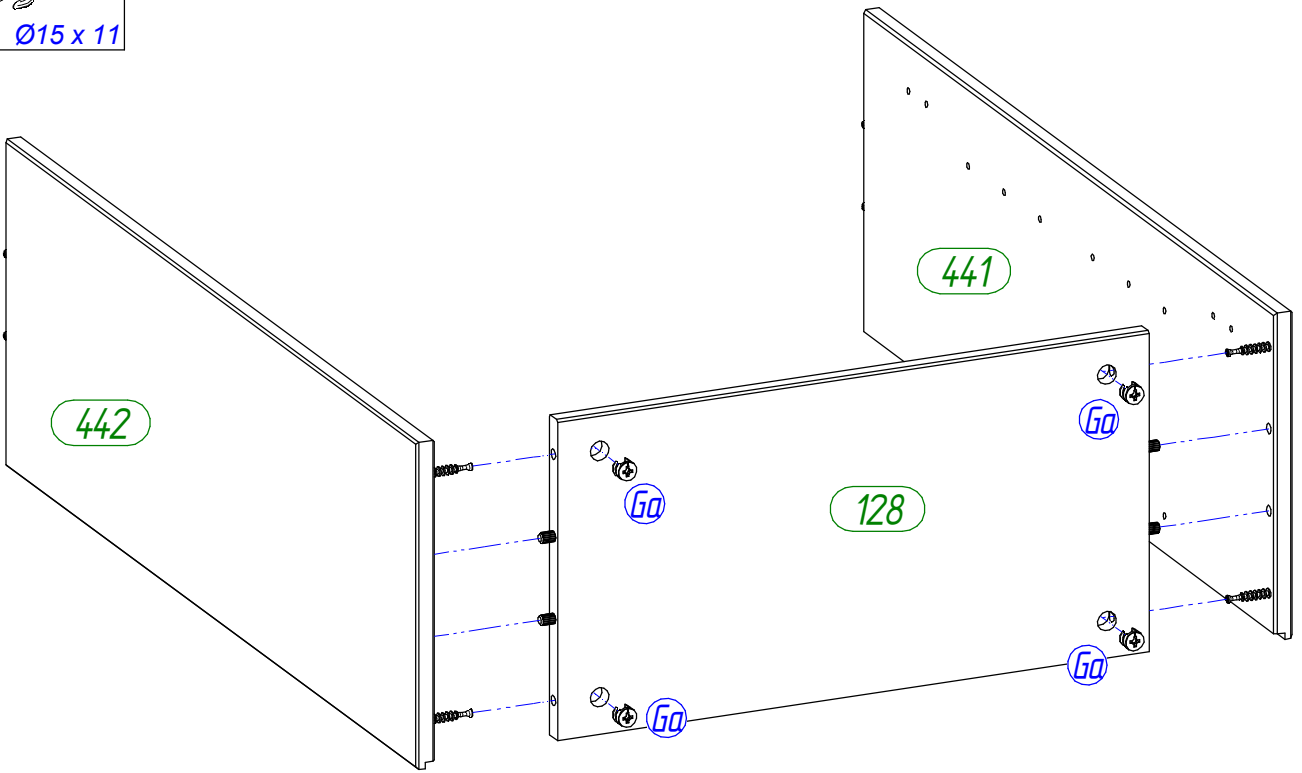

2

**Ga** 4 x  
  
Ø15 x 11

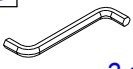

**3**

**Fb** 1 x **Hc** 4 x  
 3 mm  Ø5 x 50

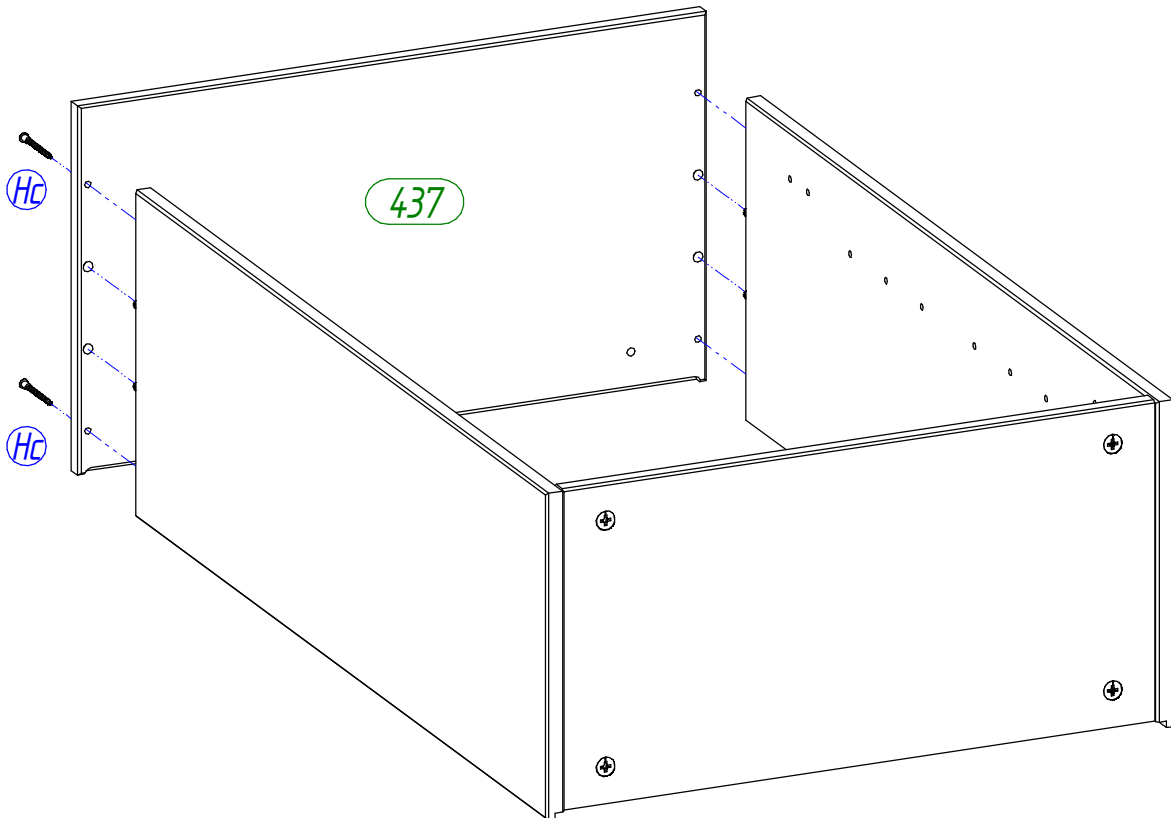



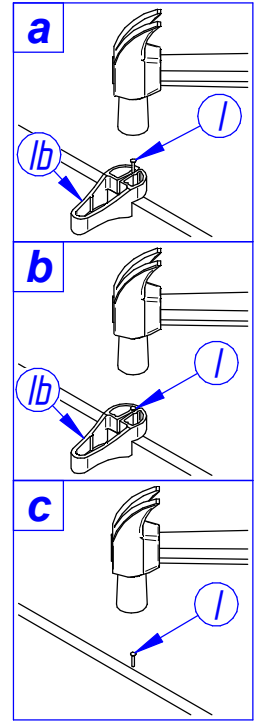
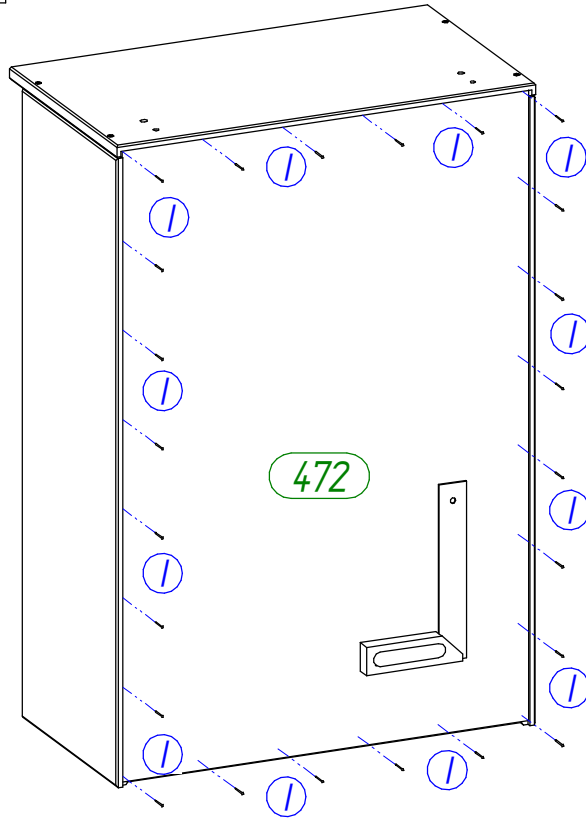
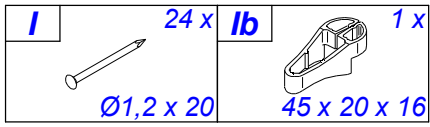

**4**

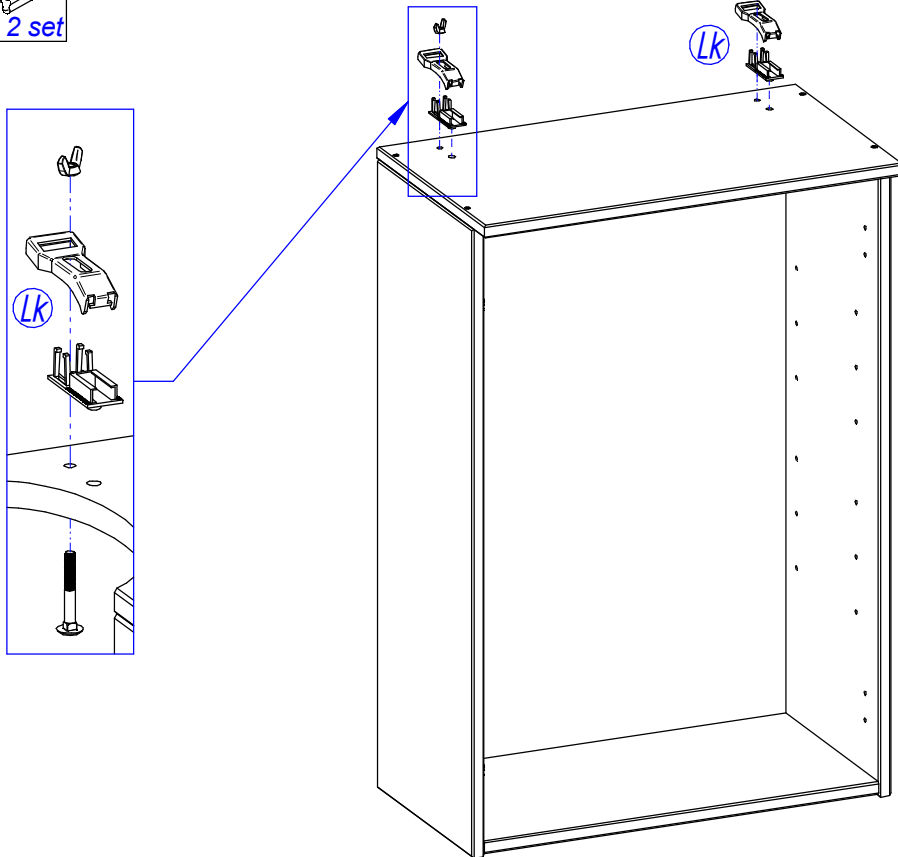
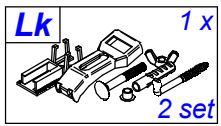

5

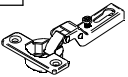

6

<b>Ce</b>	2 x	<b>Dd</b>	2 x	<b>Ea</b>	4 x	<b>No</b>	1 x
							
<i>fk.9</i>		<i>M4 x 20</i>		<i>Ø3,5 x 15</i>		<i>131 x 20</i>	

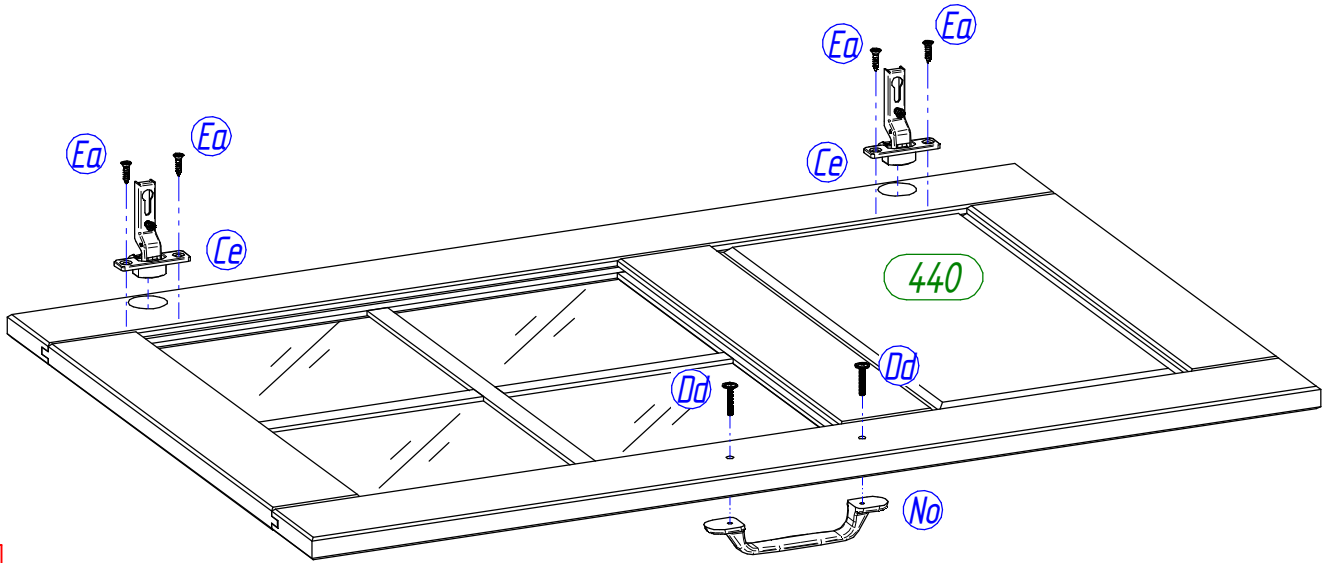

**7**

<b>N</b>	8 x
	
<i>Ø5 / Ø5</i>	

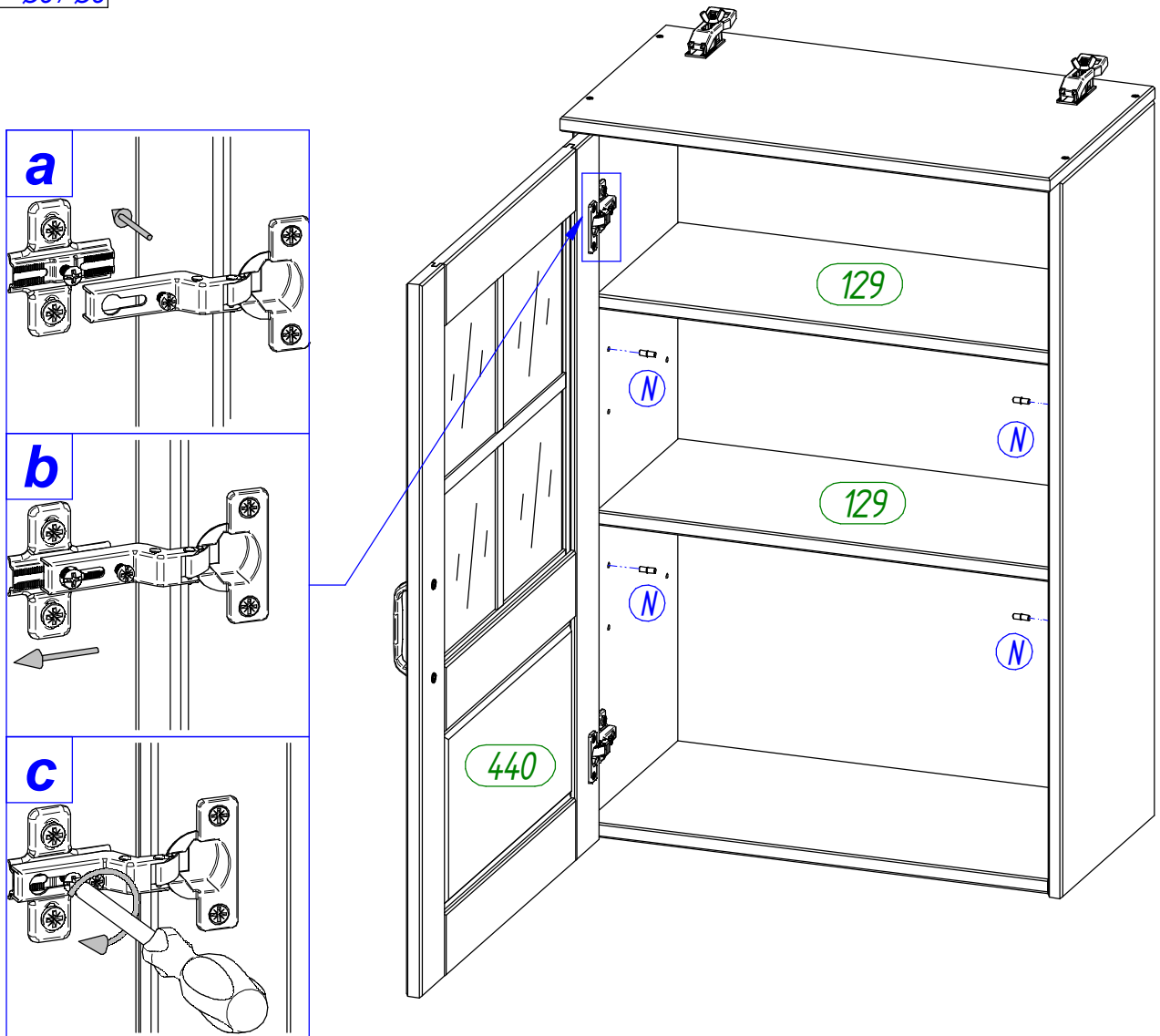

**8**

<b>(D)</b>	Bei einigen Wandtypen kann ein Spezialdübel erforderlich sein!
<b>(GB)</b>	For certain wall types, a special dowel may be necessary!
<b>(NL)</b>	Bij enkele muurtypes is een speciale plug misschien vereist!
<b>(PL)</b>	Do niektórych rodzajów ścian konieczne mogą być specjalne wkręty!
<b>(TR)</b>	Bazı duvar tiplerinde bunun için özel bir dübel gerekli olabilir!
<b>(RU)</b>	Для некоторых типов стен может потребоваться специальный дюбель!
<b>(FR)</b>	Pour certains types de murs il faut des chevilles spéciales !
<b>(IT)</b>	Per alcune strutture di parete può essere necessario un tassello speciale!
<b>(CZ)</b>	U některých typů stěn může být zapotřebí speciální hmoždinka!
<b>(SK)</b>	Pre niektoré druhy stien môže byť potrebná špeciálna hmoždinka!
<b>(HU)</b>	Egyes faltípusoknál speciális tiplít kell használni!
<b>(RO)</b>	Pentru unele tipuri de pereți este posibil să fie necesar un diblu special!

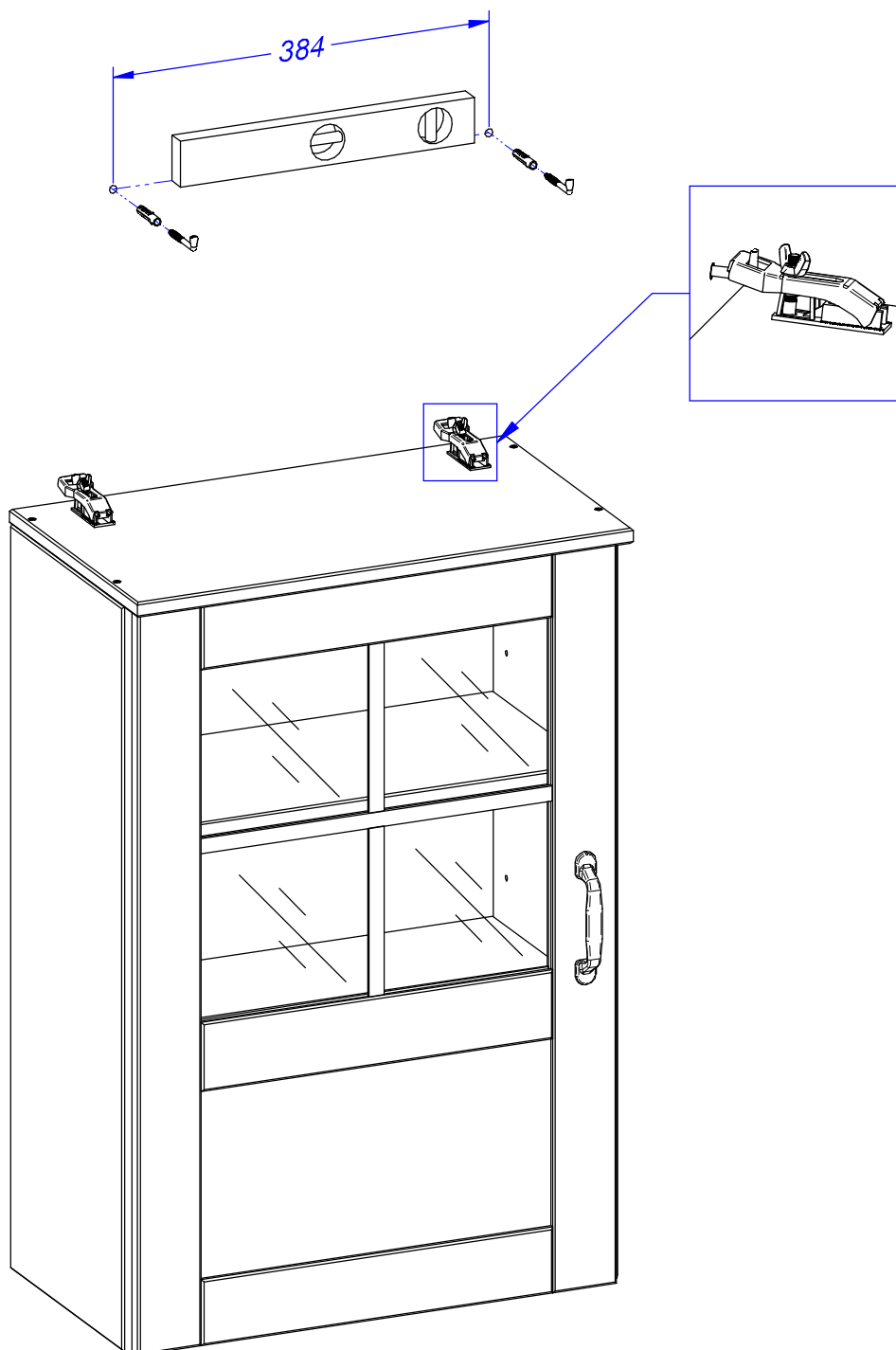



<b>D</b>	Türen einstellen (Scharniere justieren)
<b>GB</b>	Adjusting the doors (adjusting the hinges)
<b>NL</b>	Deuren instellen (scharnieren afstellen)
<b>PL</b>	Nastawić drzwi (wyrównać zawiasy)
<b>TR</b>	Kapıların ayarlanması (menteşelerin seviye ayarı)
<b>RU</b>	Регулировка дверей (регулировка шарнира)
<b>FR</b>	Régler les portes (ajuster les charnières)
<b>IT</b>	Sistemare le porte (regolare le cerniere)
<b>CZ</b>	Vyrovnejte dvířka (seřídte závěsy)
<b>SK</b>	Nastavenie dverí (nastavenie závesov)
<b>HU</b>	Állítsa be az ajtókat (állítsa be a zsanérokat)
<b>RO</b>	Reglare ușii (ajustare balamale)

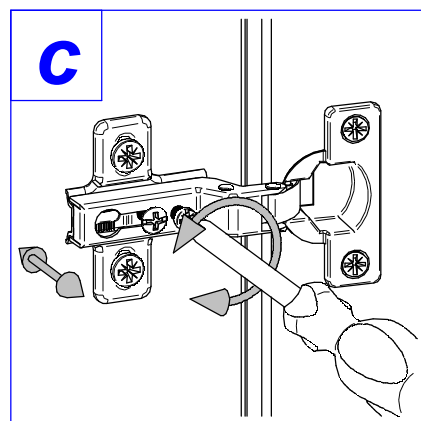
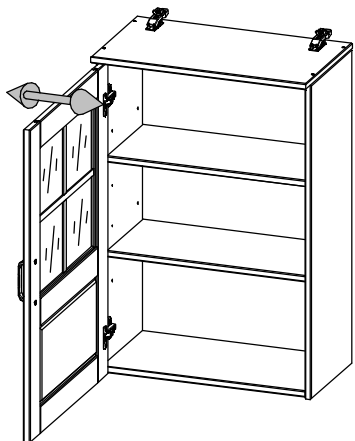
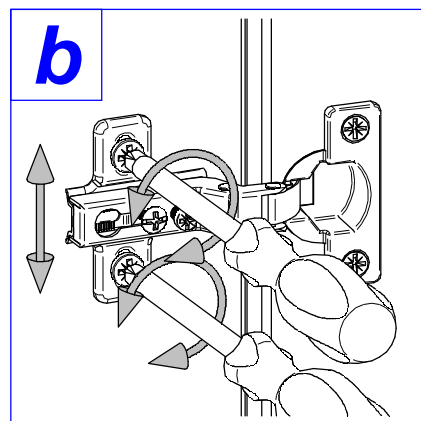
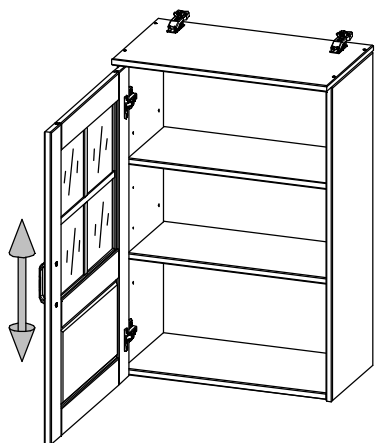
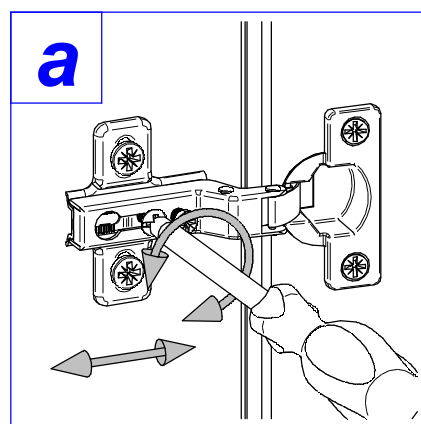
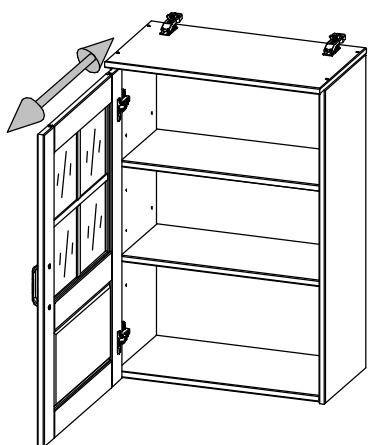

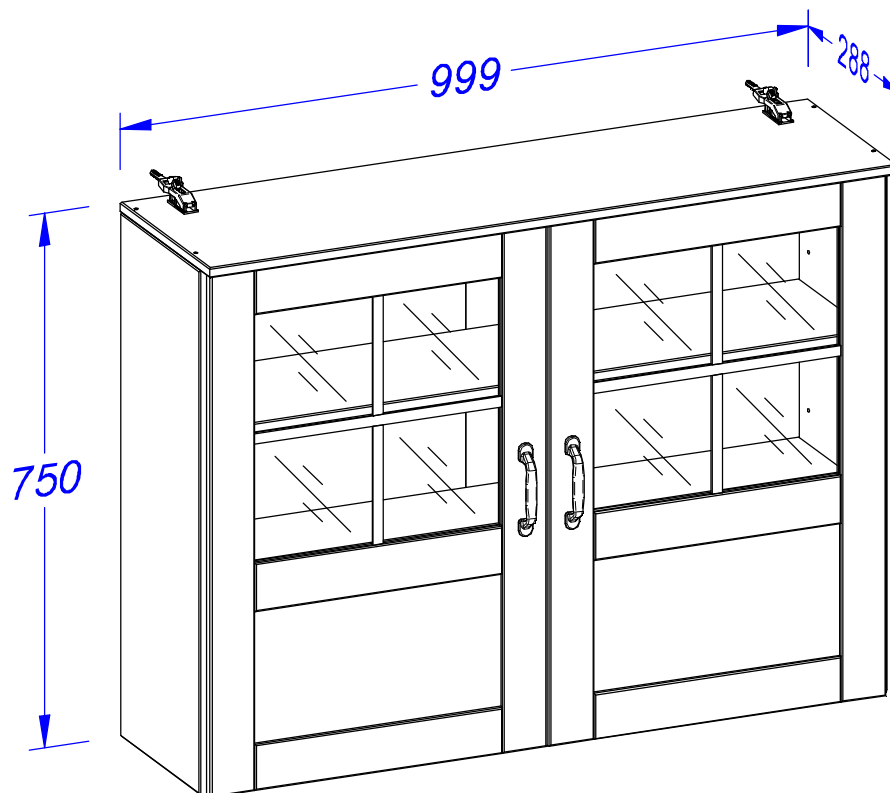

**(D)** *Montageanleitung*

**(NL)** *Handleiding voor de montage*

**(TR)** *Montaj talimatı*

**(FR)** *Notice de montage*

**(CZ)** *Montážní návod*

**(HU)** *Szerelési útmutató*

**(GB)** *Assembly instructions*

**(PL)** *Instrukcja montażu*

**(RU)** *Инструкция по монтажу*

**(IT)** *Istruzioni di montaggio*

**(SK)** *Návod na montáž*









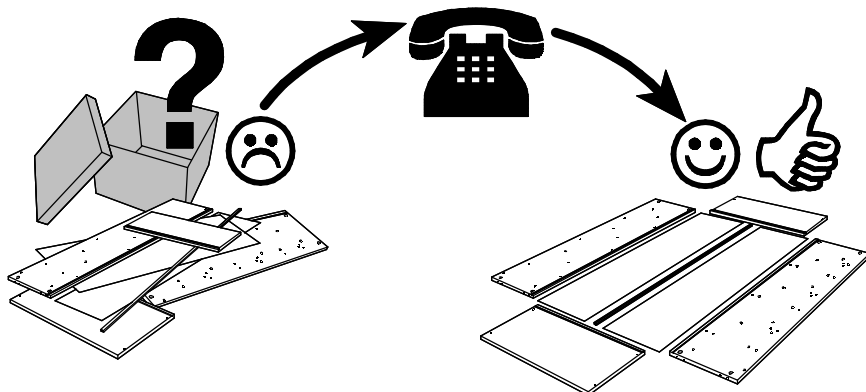
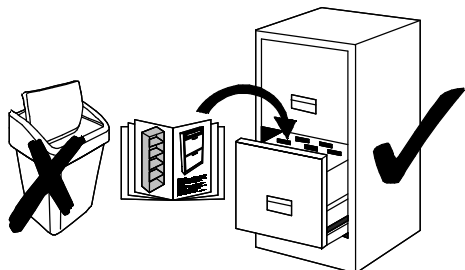

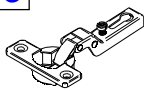

**(RO)** *Instrucțiuni de montaj*

Name • Nom • Nome • Naam • Nazwa • Jméno •  
Názov • Név • Denumire • Isim • Название

Nr. • No. • N° • Номер • Č • Sz

Typ • Type • Tip • Típus • Tipo • Тип

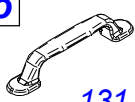

<b>A</b>	8 x	<b>C</b>	4 x	<b>Ce</b>	4 x	<b>Dd</b>	4 x	<b>Ea</b>	8 x	<b>Fb</b>	1 x
											
Ø8 x 35		2 mm		fk.9		M4 x 20		Ø3,5 x 15		3 mm	
<b>G</b>	4 x	<b>Ga</b>	4 x	<b>Hc</b>	4 x	<b>I</b>	50 x	<b>lb</b>	1 x	<b>Lk</b>	1 x
											
L - 34		Ø15 x 11		Ø5 x 50		Ø1,2 x 20		45 x 20 x 16		2 set	
<b>N</b>	8 x	<b>No</b>	2 x								
											
Ø5 / Ø5		131 x 20									

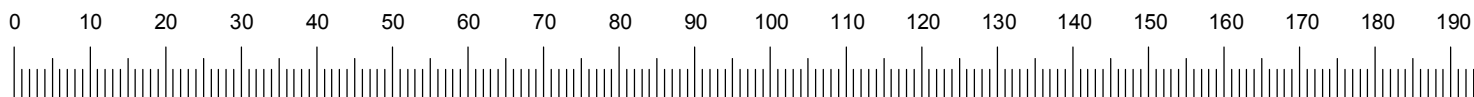
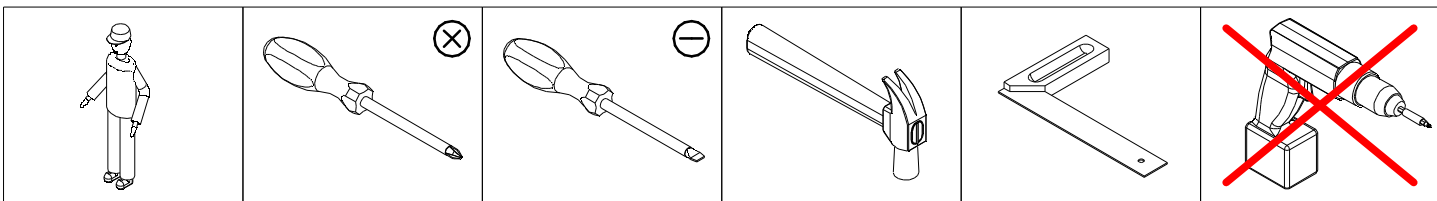

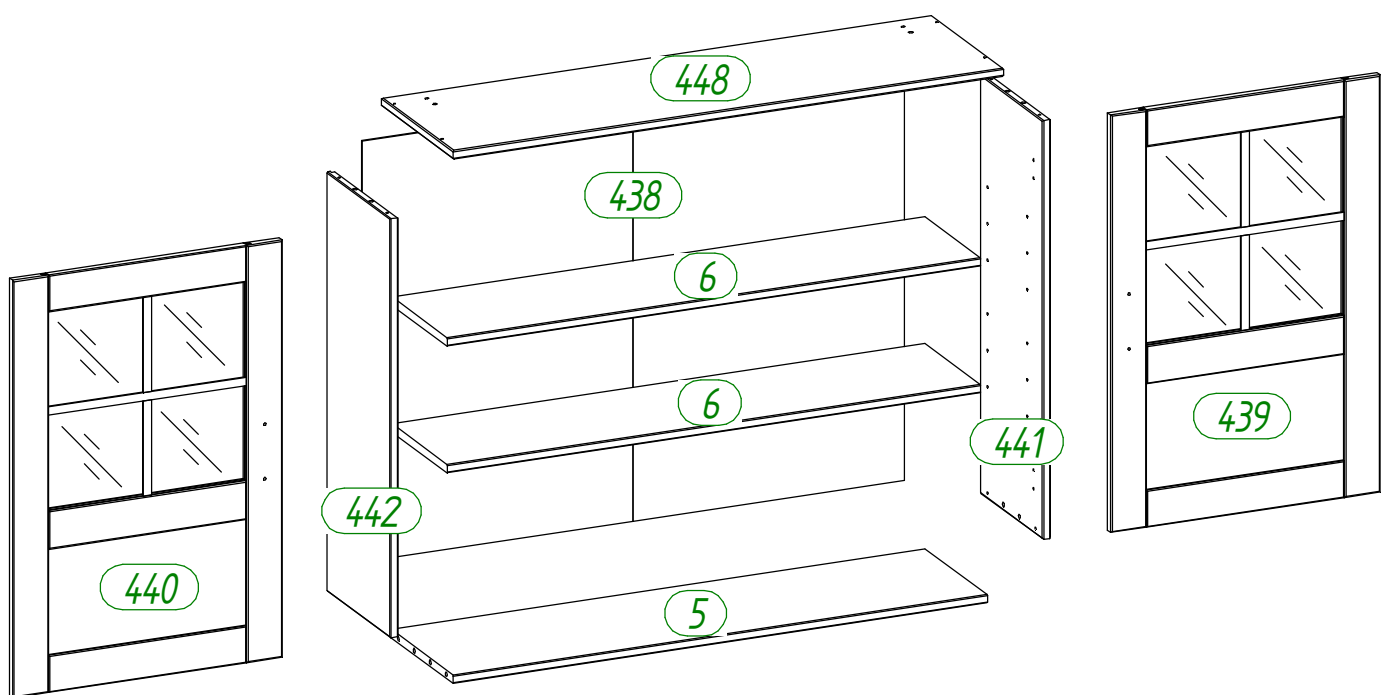

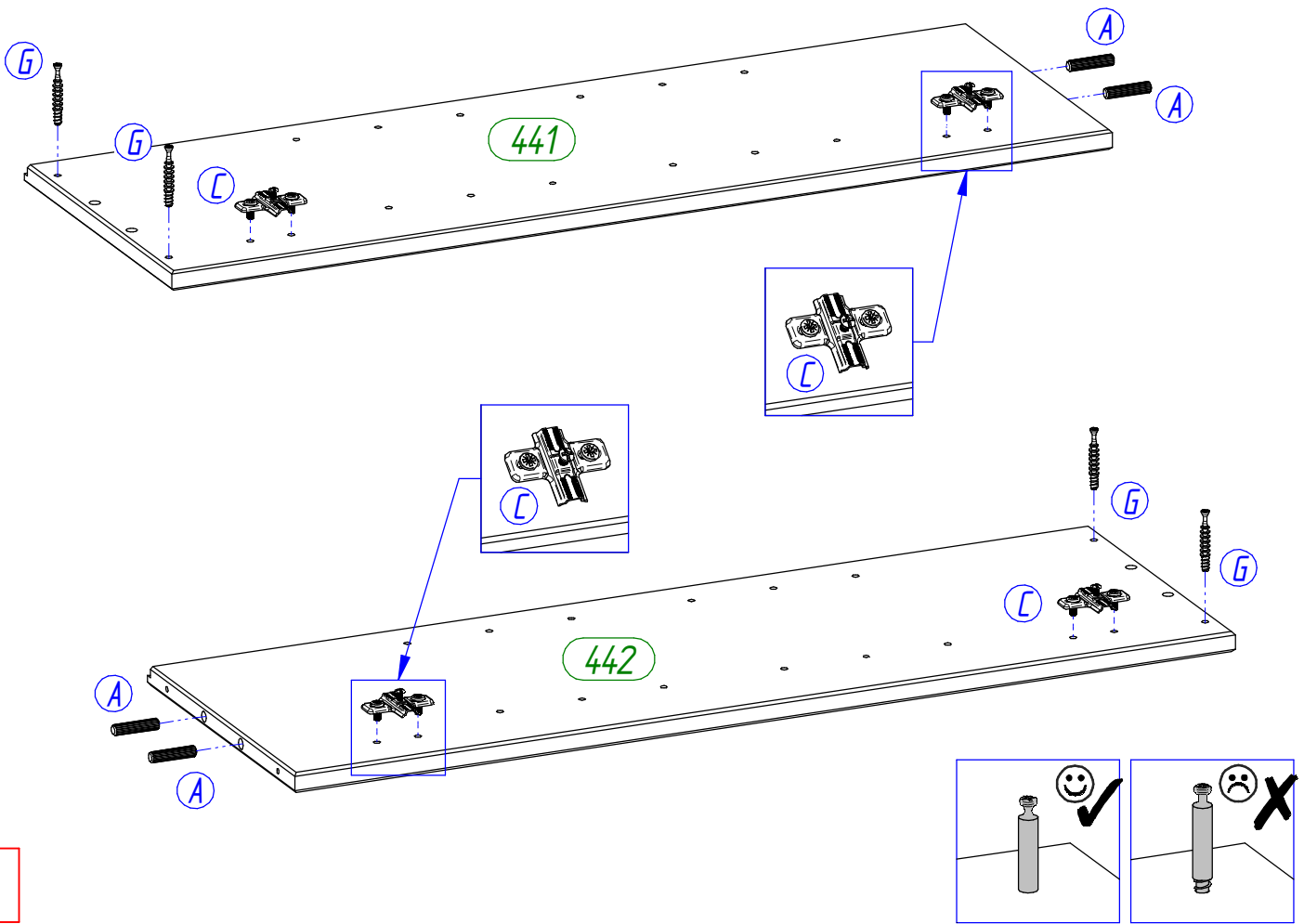
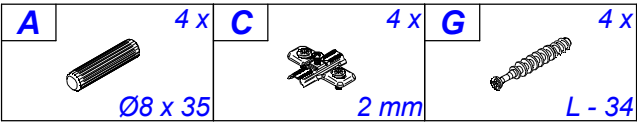
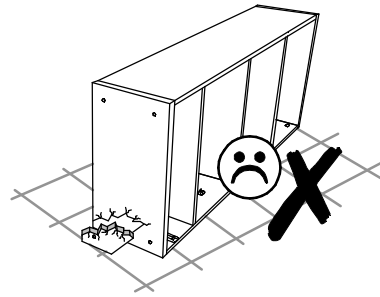
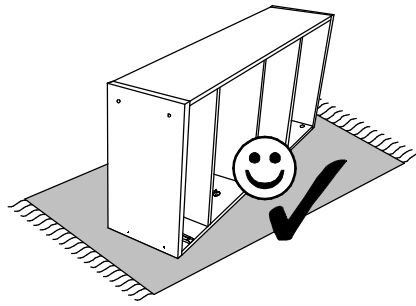

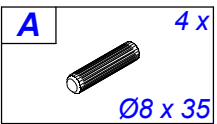

1



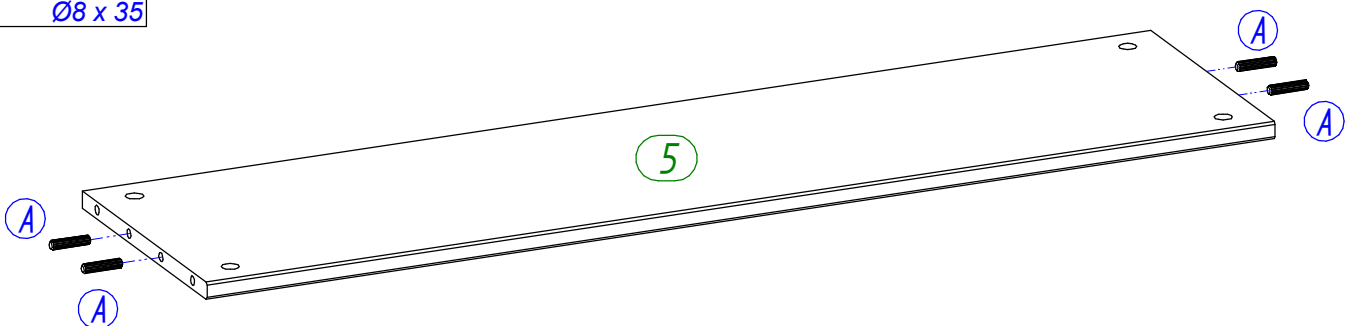

2

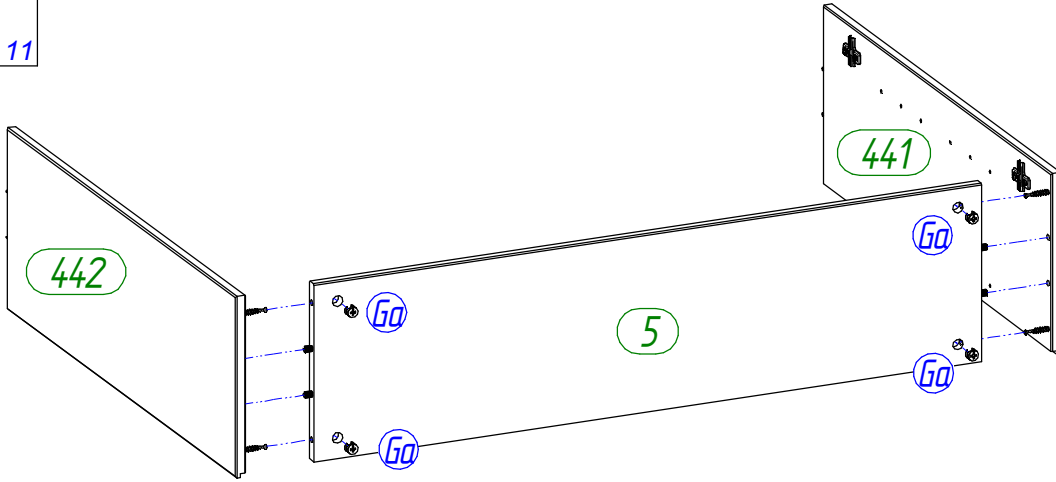

**Ga** 4 x  
  
 Ø15 x 11



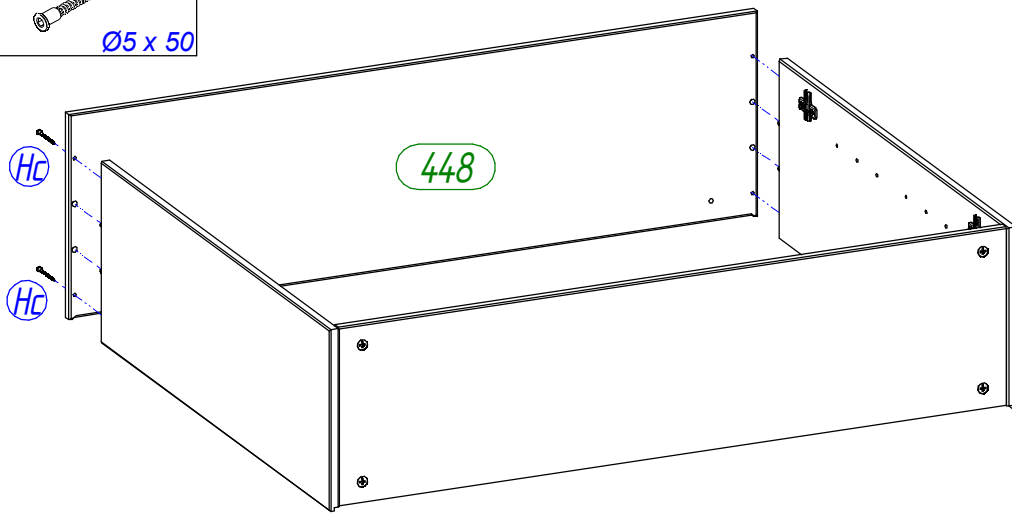

**3**

**Fb** 1 x **Hc** 4 x  
  
 3 mm   
 Ø5 x 50



**4**

**I** 32 x **lb** 1 x  
  
 Ø1,2 x 20   
 45 x 20 x 16

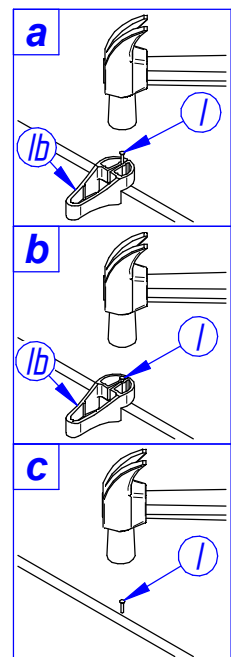
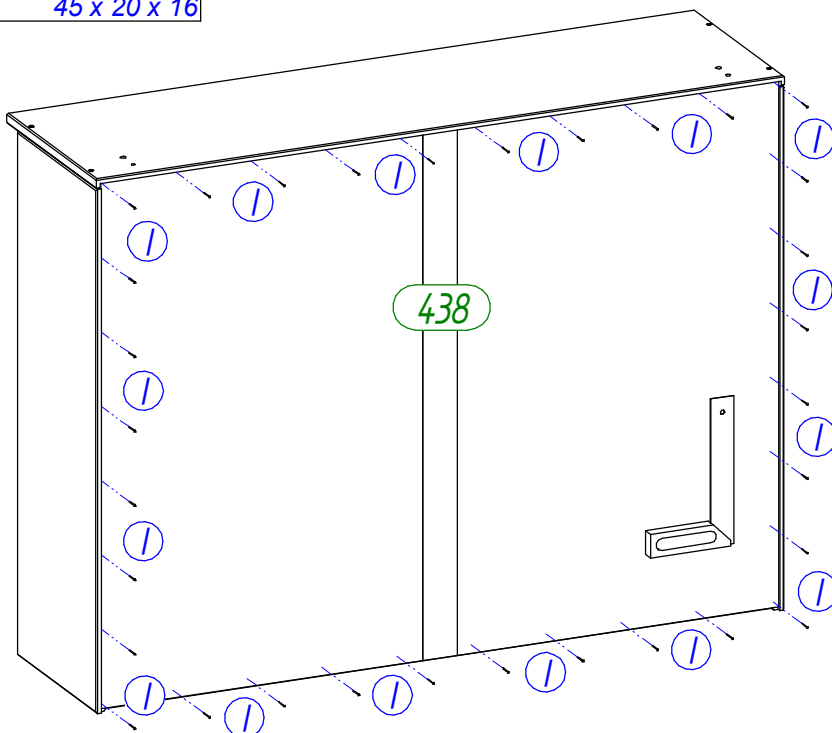

**5**

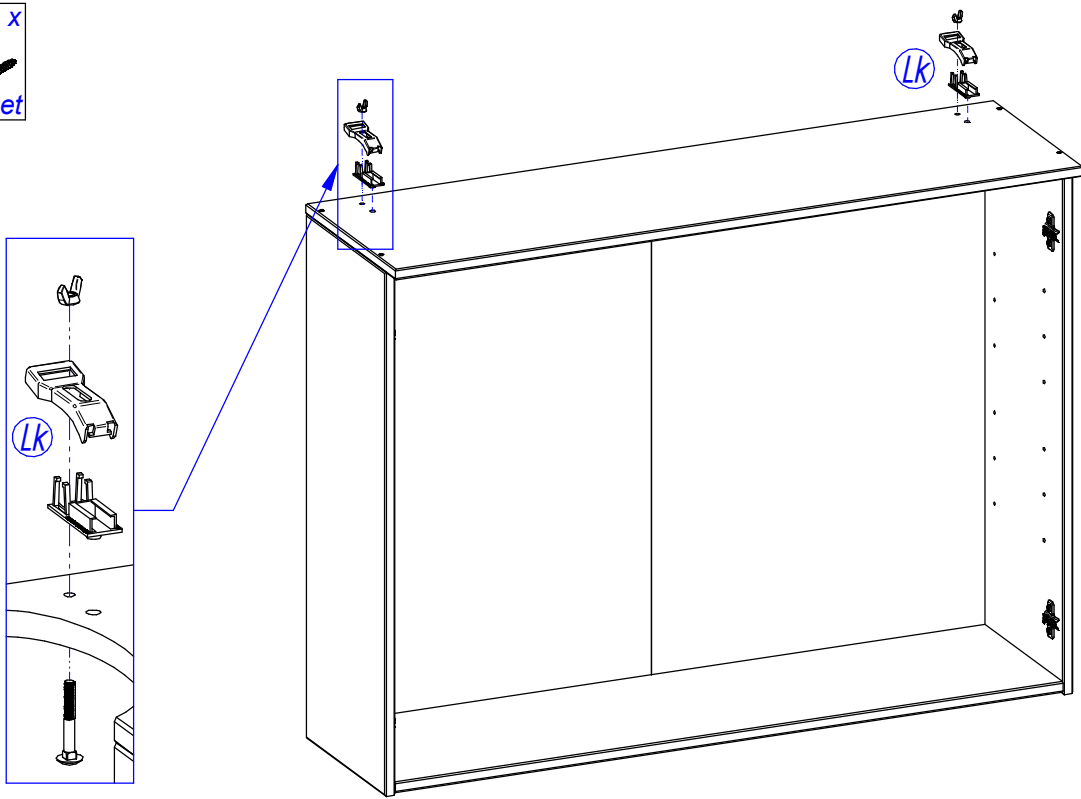
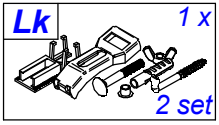

6

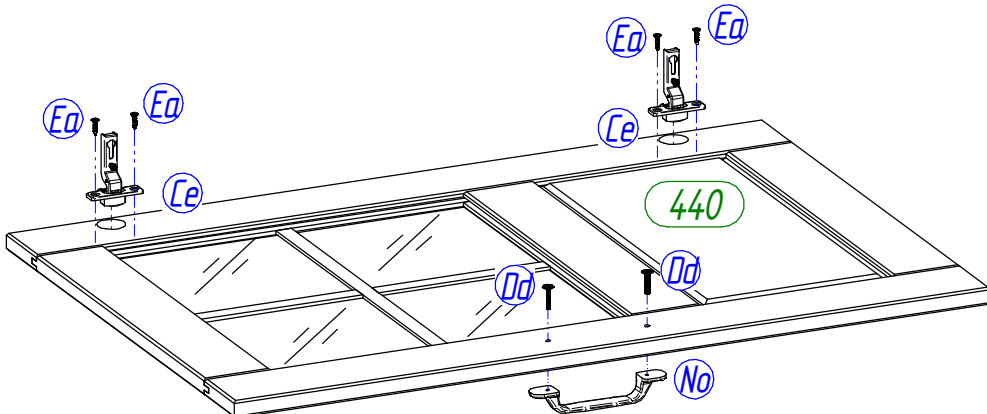
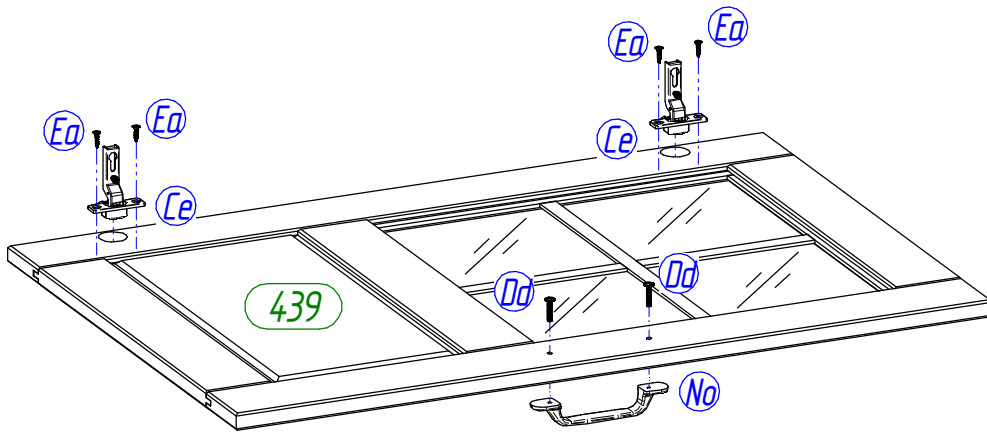
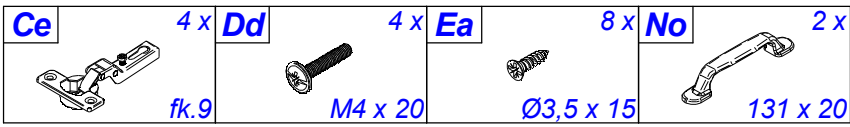

7

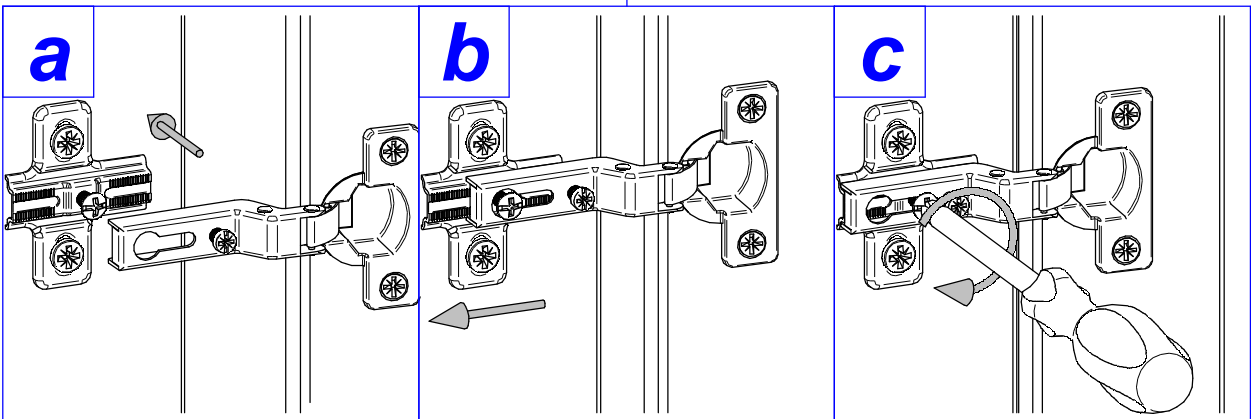
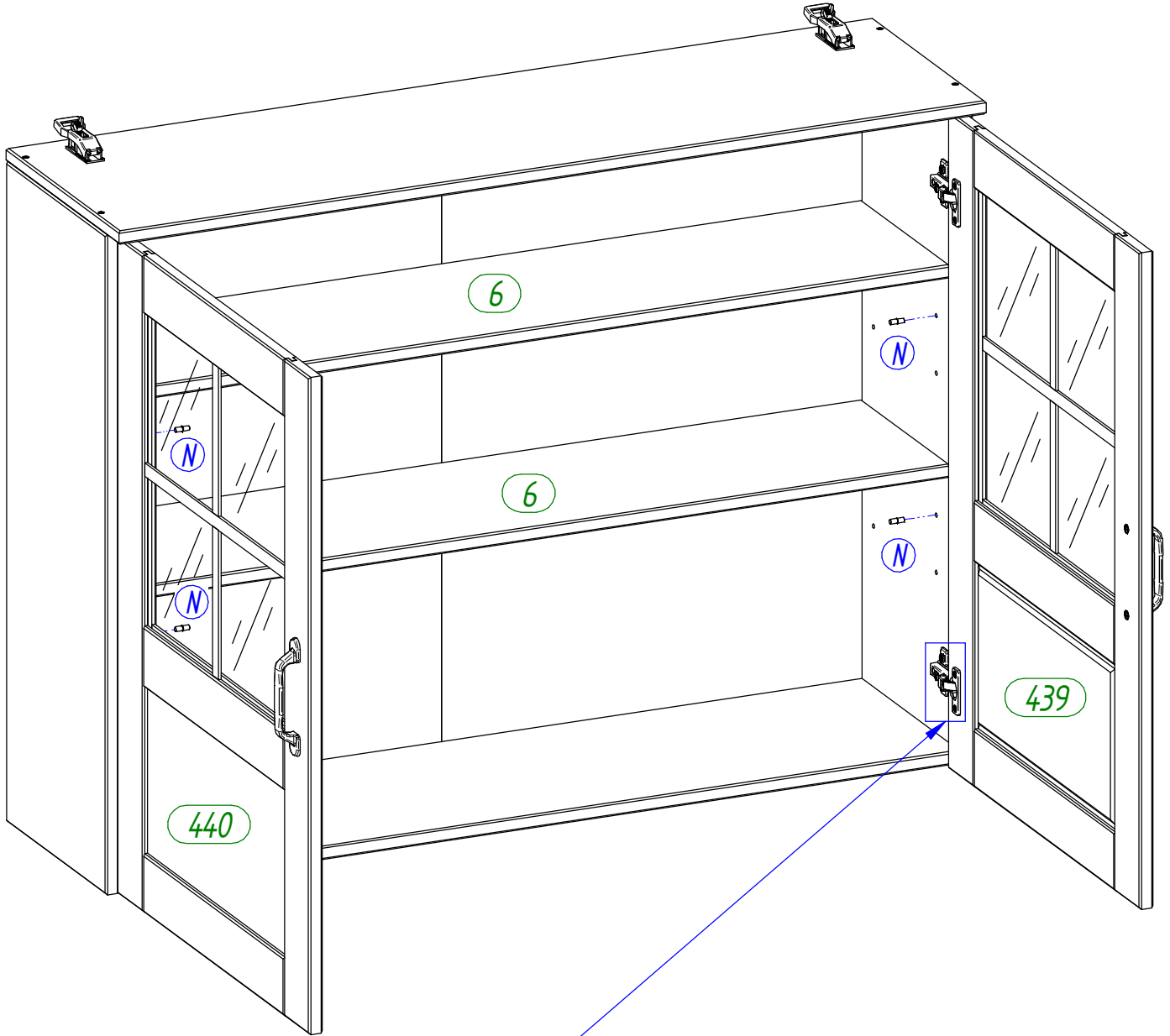
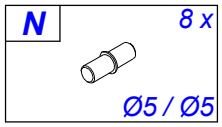

**8**



<b>(D)</b>	Bei einigen Wandtypen kann ein Spezialdübel erforderlich sein!
<b>(GB)</b>	For certain wall types, a special dowel may be necessary!
<b>(NL)</b>	Bij enkele muurtypes is een speciale plug misschien vereist!
<b>(PL)</b>	Do niektórych rodzajów ścian konieczne mogą być specjalne wkręty!
<b>(TR)</b>	Bazı duvar tiplerinde bunun için özel bir dübel gerekli olabilir!
<b>(RU)</b>	Для некоторых типов стен может потребоваться специальный дюбель!
<b>(FR)</b>	Pour certains types de murs il faut des chevilles spéciales !
<b>(IT)</b>	Per alcune strutture di parete può essere necessario un tassello speciale!
<b>(CZ)</b>	U některých typů stěn může být zapotřebí speciální hmoždinka!
<b>(SK)</b>	Pre niektoré druhy stien môže byť potrebná špeciálna hmoždinka!
<b>(HU)</b>	Egyes faltípusoknál speciális tiplít kell használni!
<b>(RO)</b>	Pentru unele tipuri de pereți este posibil să fie necesar un diblu special!

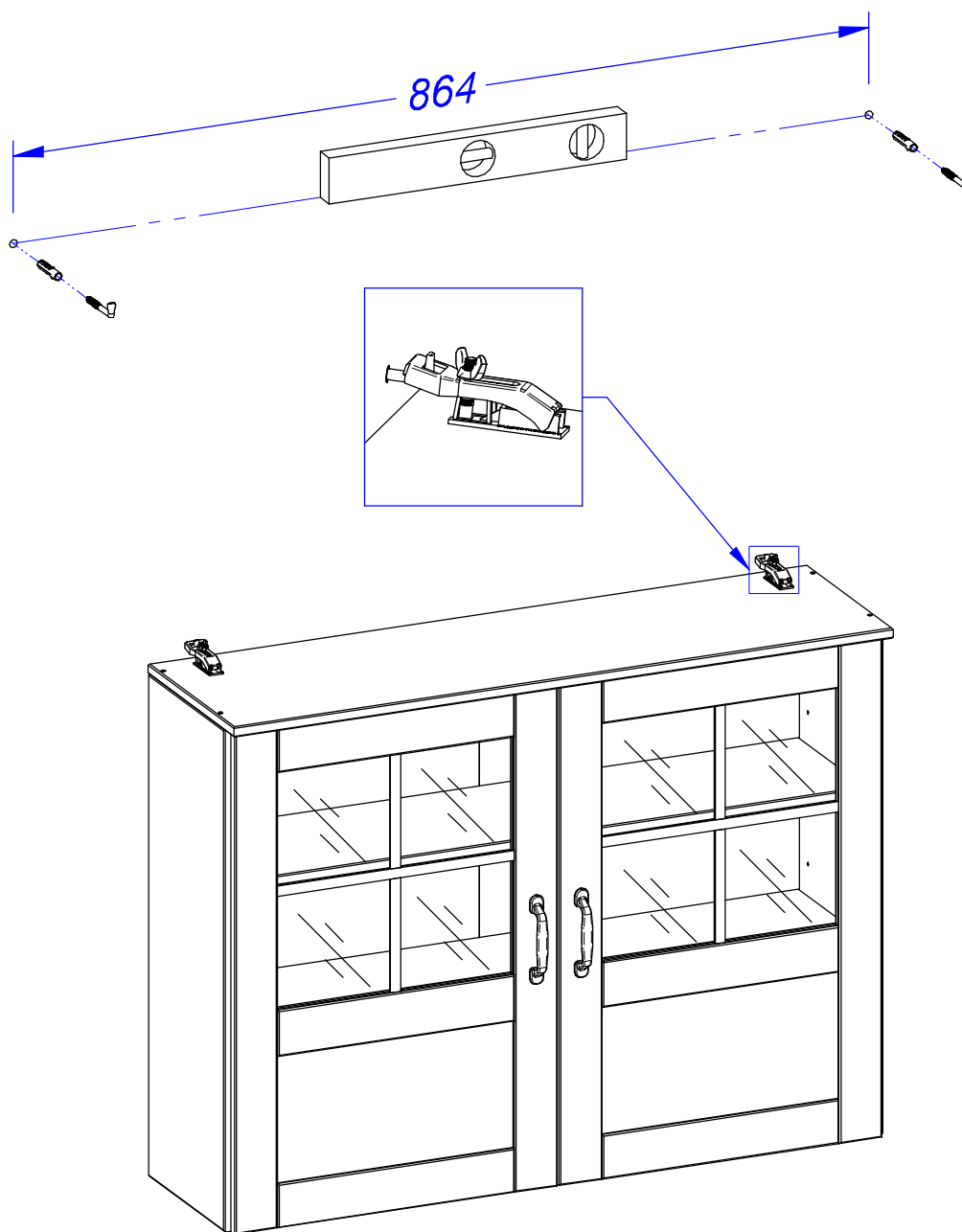

<b>D</b>	Türen einstellen (Scharniere justieren)
<b>GB</b>	Adjusting the doors (adjusting the hinges)
<b>NL</b>	Deuren instellen (scharnieren afstellen)
<b>PL</b>	Nastawić drzwi (wyrównać zawiasy)
<b>TR</b>	Kapıların ayarlanması (menteşelerin seviye ayarı)
<b>RU</b>	Регулировка дверей (регулировка шарнира)
<b>FR</b>	Régler les portes (ajuster les charnières)
<b>IT</b>	Sistemare le porte (regolare le cerniere)
<b>CZ</b>	Vyrovnejte dvířka (seřídte závěsy)
<b>SK</b>	Nastavenie dverí (nastavenie závesov)
<b>HU</b>	Állítsa be az ajtókat (állítsa be a zsanérokat)
<b>RO</b>	Reglare ușii (ajustare balamale)

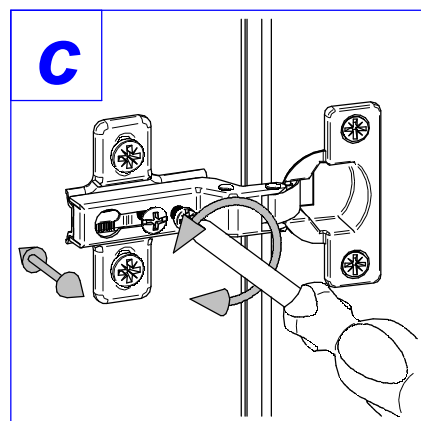
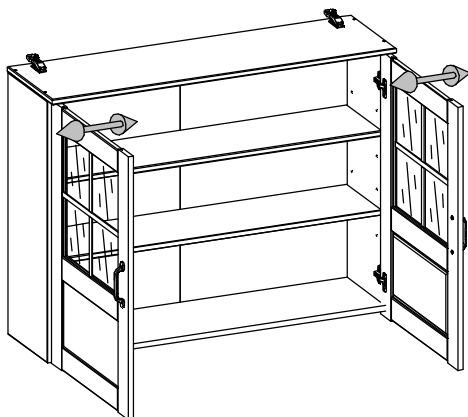
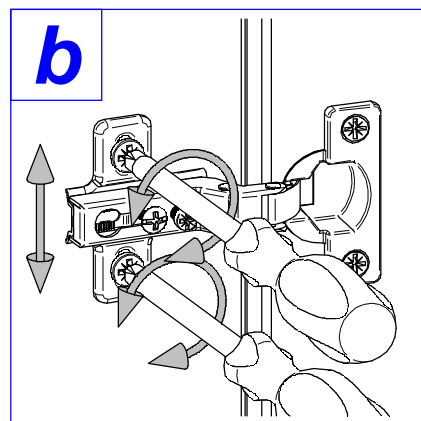
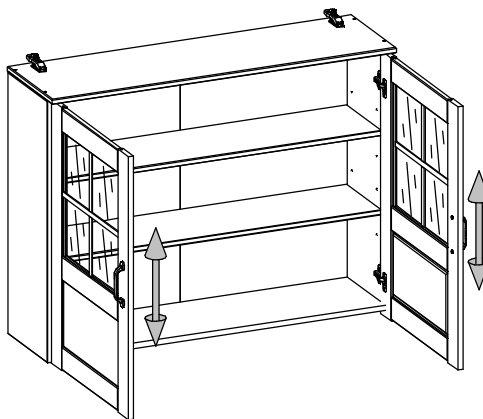
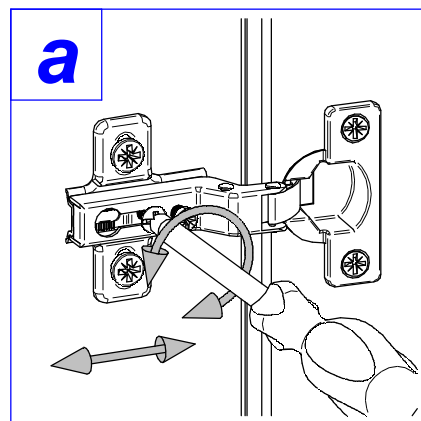
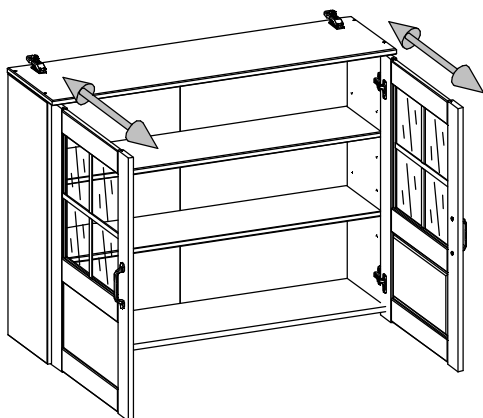

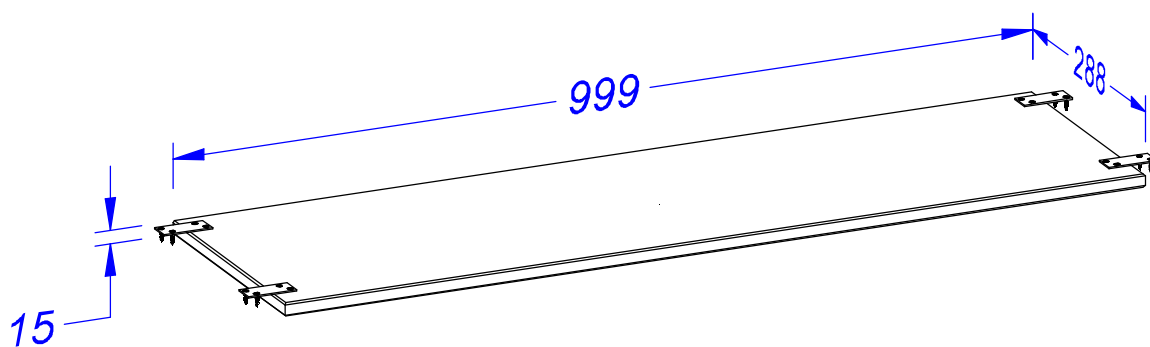

**(D)** *Montageanleitung*

**(NL)** *Handleiding voor de montage*

**(TR)** *Montaj talimatı*

**(FR)** *Notice de montage*

**(CZ)** *Montážní návod*

**(HU)** *Szerelési útmutató*

**(GB)** *Assembly instructions*

**(PL)** *Instrukcja montażu*

**(RU)** *Инструкция по монтажу*

**(IT)** *Istruzioni di montaggio*

**(SK)** *Návod na montáž*

**(RO)** *Instrucțiuni de montaj*

Name • Nom • Nome • Naam • Nazwa • Jméno •  
Názov • Név • Denumire • Isim • Название

Nr. • No. • N° • Номер • Č • Sz

Typ • Type • Tip • Tipus • Tipo • Тип

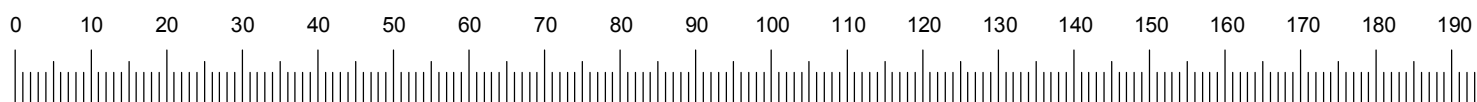
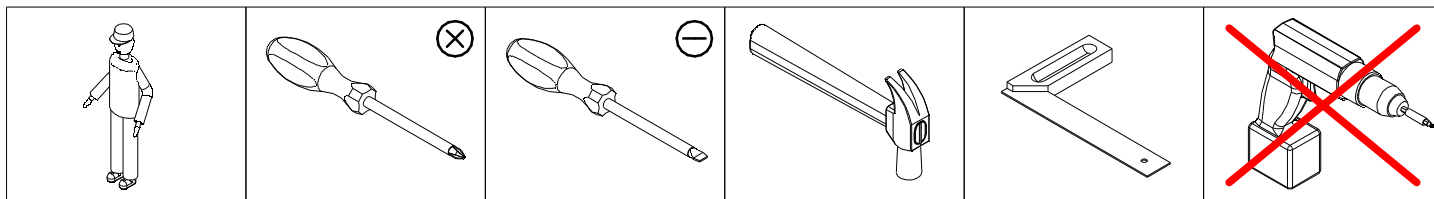
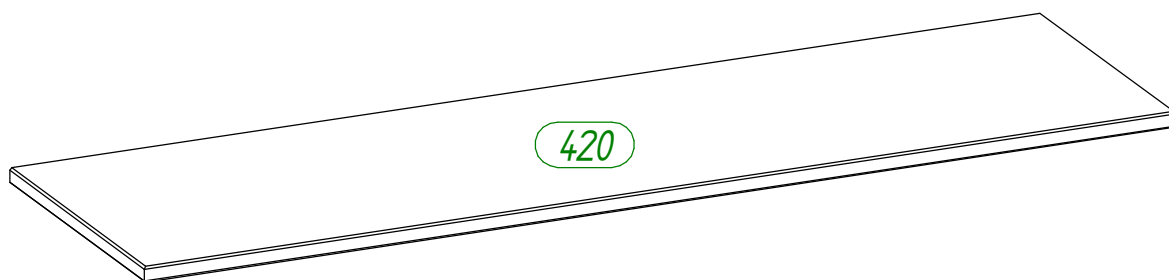
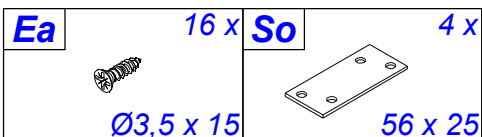
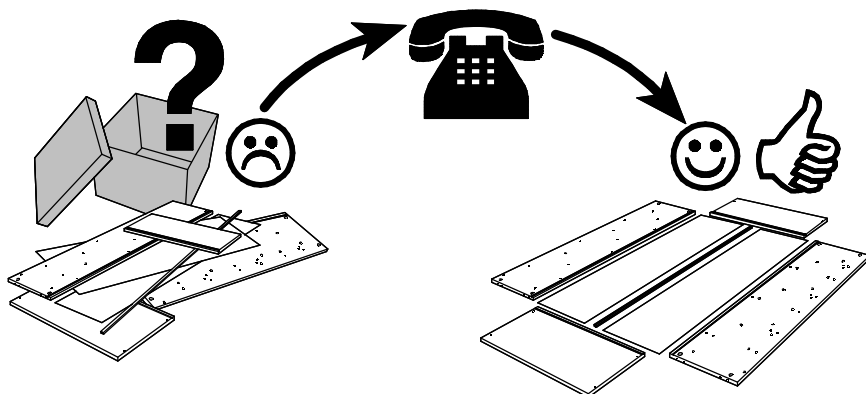
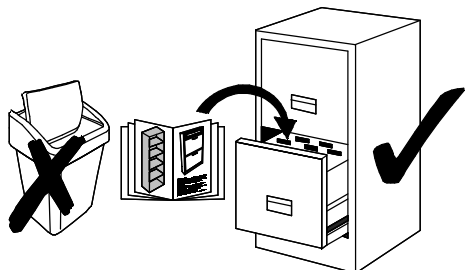

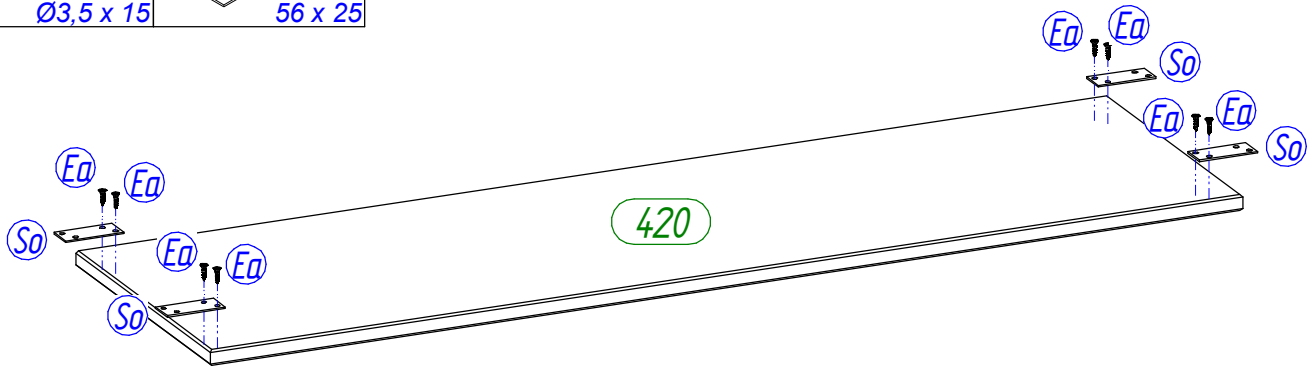
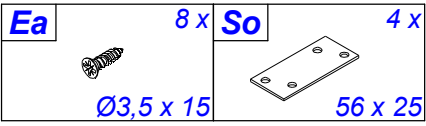
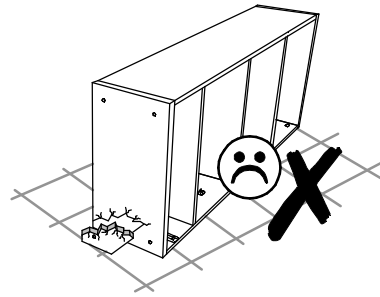
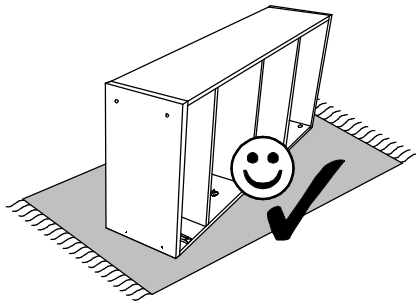

1

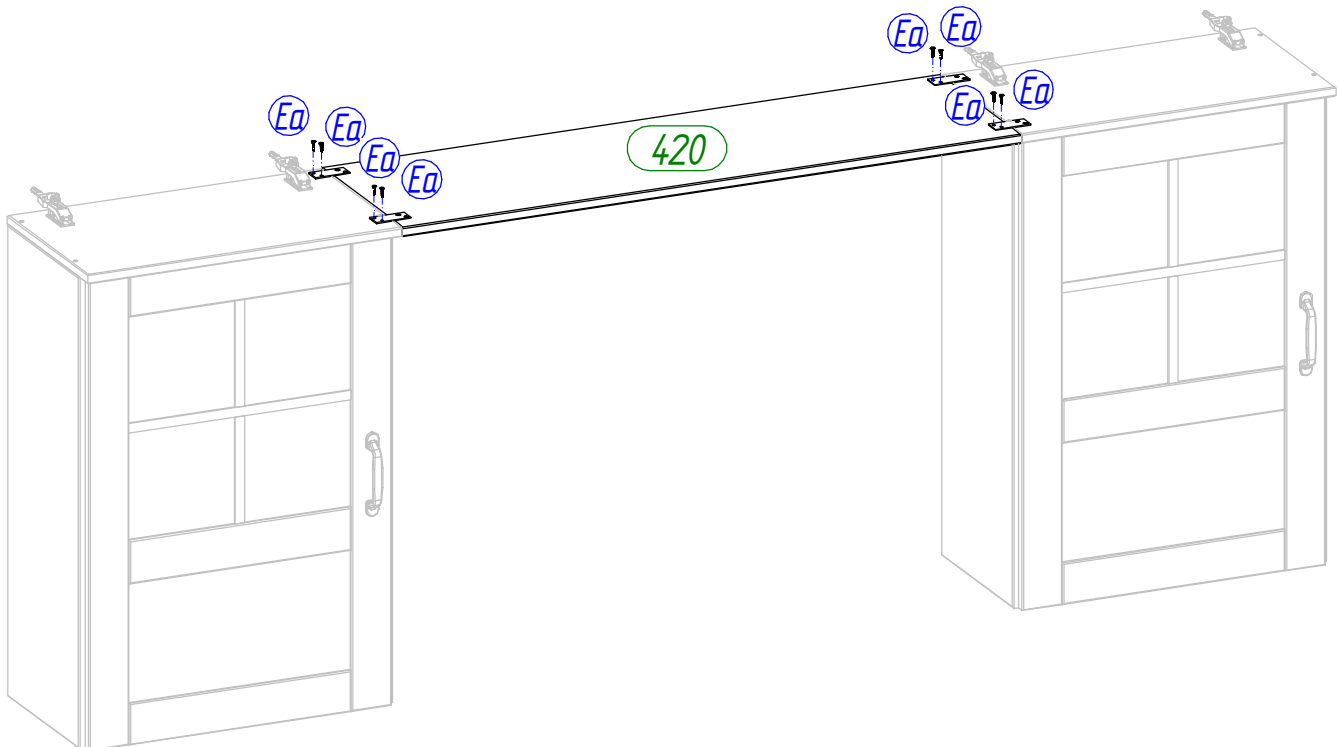
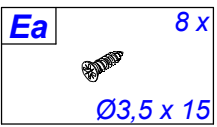

2

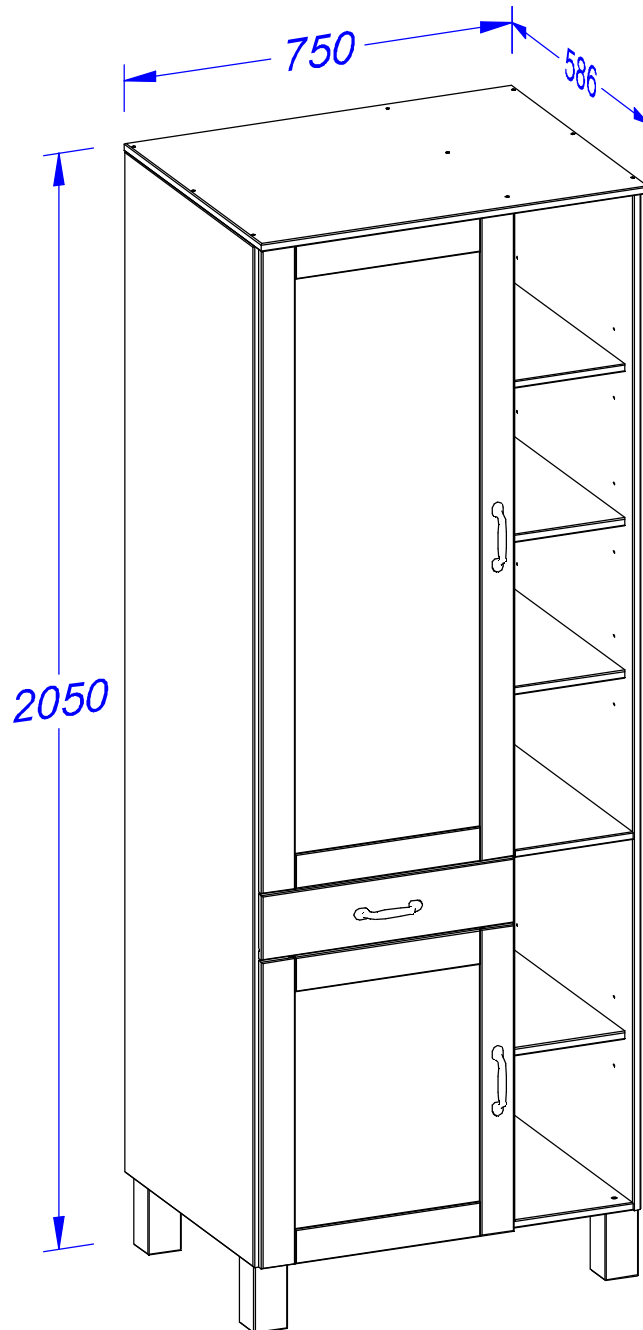

**(D)** *Montageanleitung*

**(NL)** *Handleiding voor de montage*

**(TR)** *Montaj talimatı*

**(FR)** *Notice de montage*

**(CZ)** *Montážní návod*

**(HU)** *Szerelési útmutató*

**(GB)** *Assembly instructions*

**(PL)** *Instrukcja montażu*

**(RU)** *Инструкция по монтажу*

**(IT)** *Istruzioni di montaggio*

**(SK)** *Návod na montáž*









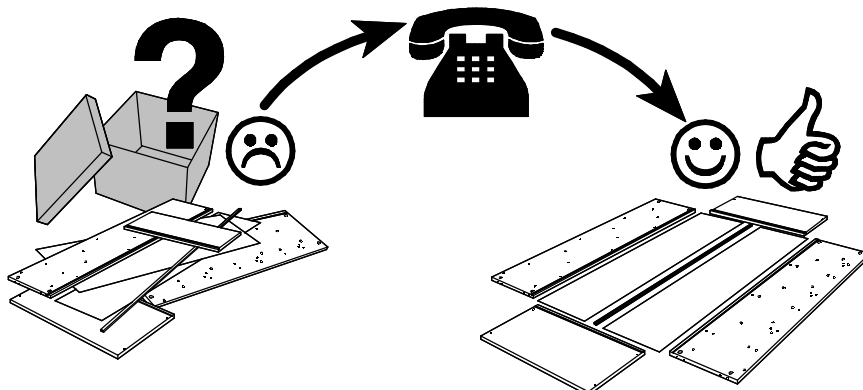
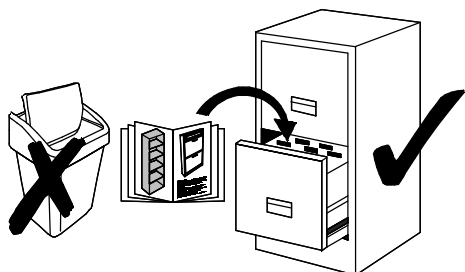

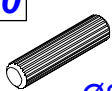
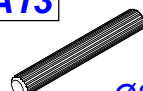

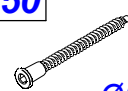
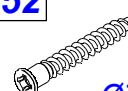
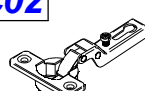

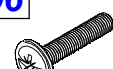

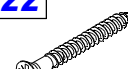

**(RO)** *Instrucțiuni de montaj*

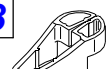
Name • Nom • Nome • Naam • Nazwa • Иméно •  
Názov • Név • Denumire • Isim • Название

Nr. • No. • N° • Номер • Č • Sz

Typ • Type • Tip • Tipus • Tipo • Тип

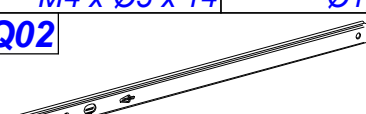

<b>A10</b> 18 x  Ø8 x 35	<b>A13</b> 2 x  Ø8 x 60	<b>B03</b> 6 x  Ø5,8 x 11	<b>B50</b> 12 x  Ø5 x 50	<b>B52</b> 4 x  Ø7 x 50	<b>C02</b> 4 x  fk.9
<b>C20</b> 4 x  2 mm	<b>D02</b> 2 x  M4 x 10	<b>D06</b> 6 x  M4 x 20	<b>E17</b> 10 x  Ø3,5 x 15	<b>E22</b> 4 x  Ø3,5 x 35	<b>E38</b> 1 x  Ø4,0 x 60
<b>F02</b> 1 x  3 mm	<b>F04</b> 1 x  4 mm	<b>F08</b> 1 x  45 x 20 x 16	<b>G02</b> 20 x  Ø15 x 11	<b>G06</b> 14 x  L - 34	<b>G08</b> 6 x  M4 / 7,0 x 34
<b>G12</b> 3 x  M4 x Ø5 x 14	<b>I01</b> 75 x  Ø1,2 x 20	<b>K03</b> 1 x  20 x 42 x 70	<b>N01</b> 28 x  Ø5 / Ø5	<b>P23</b> 3 x  131 x 20	
<b>Q02</b> 2 x  17 x 430					

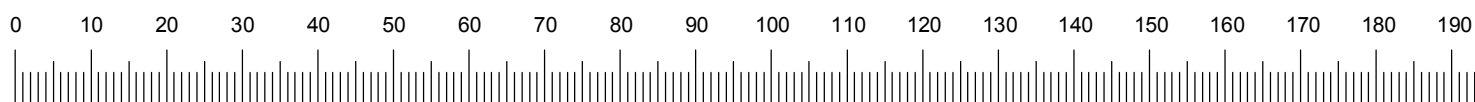
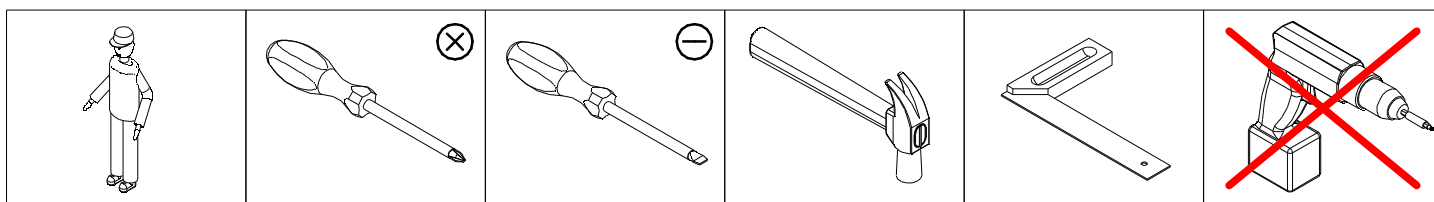

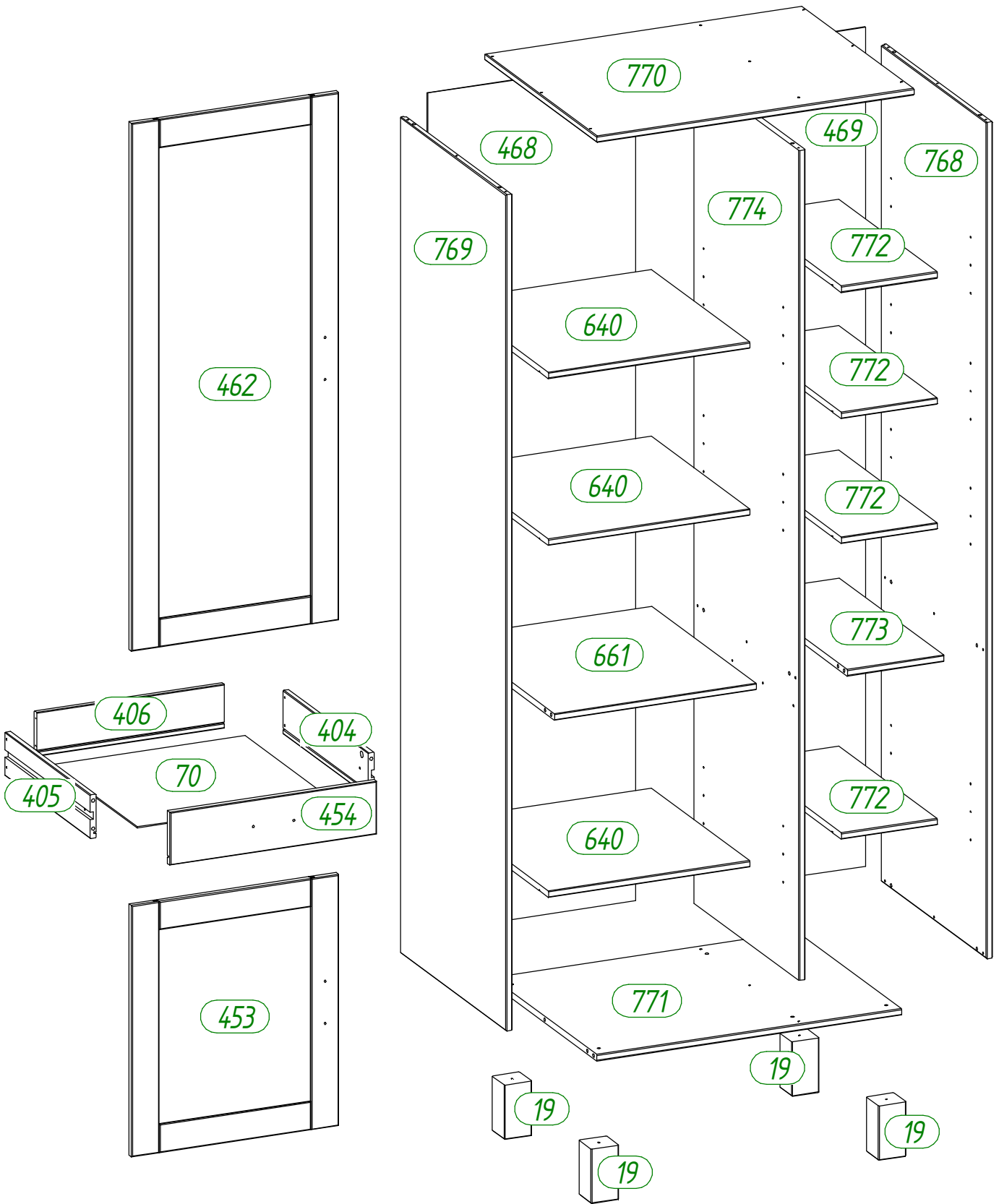



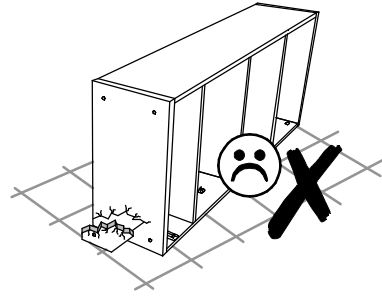
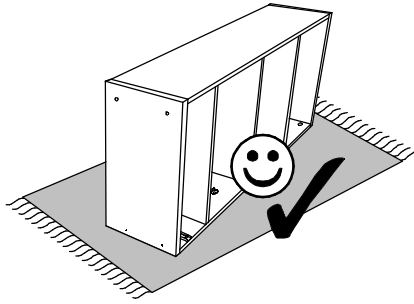

<b>A10</b>	4 x	<b>B03</b>	3 x	<b>C20</b>	4 x	<b>G06</b>	12 x	<b>Q02</b>	1 x
Ø8 x 35		Ø5,8 x 11		2 mm		L - 34		17 x 430	

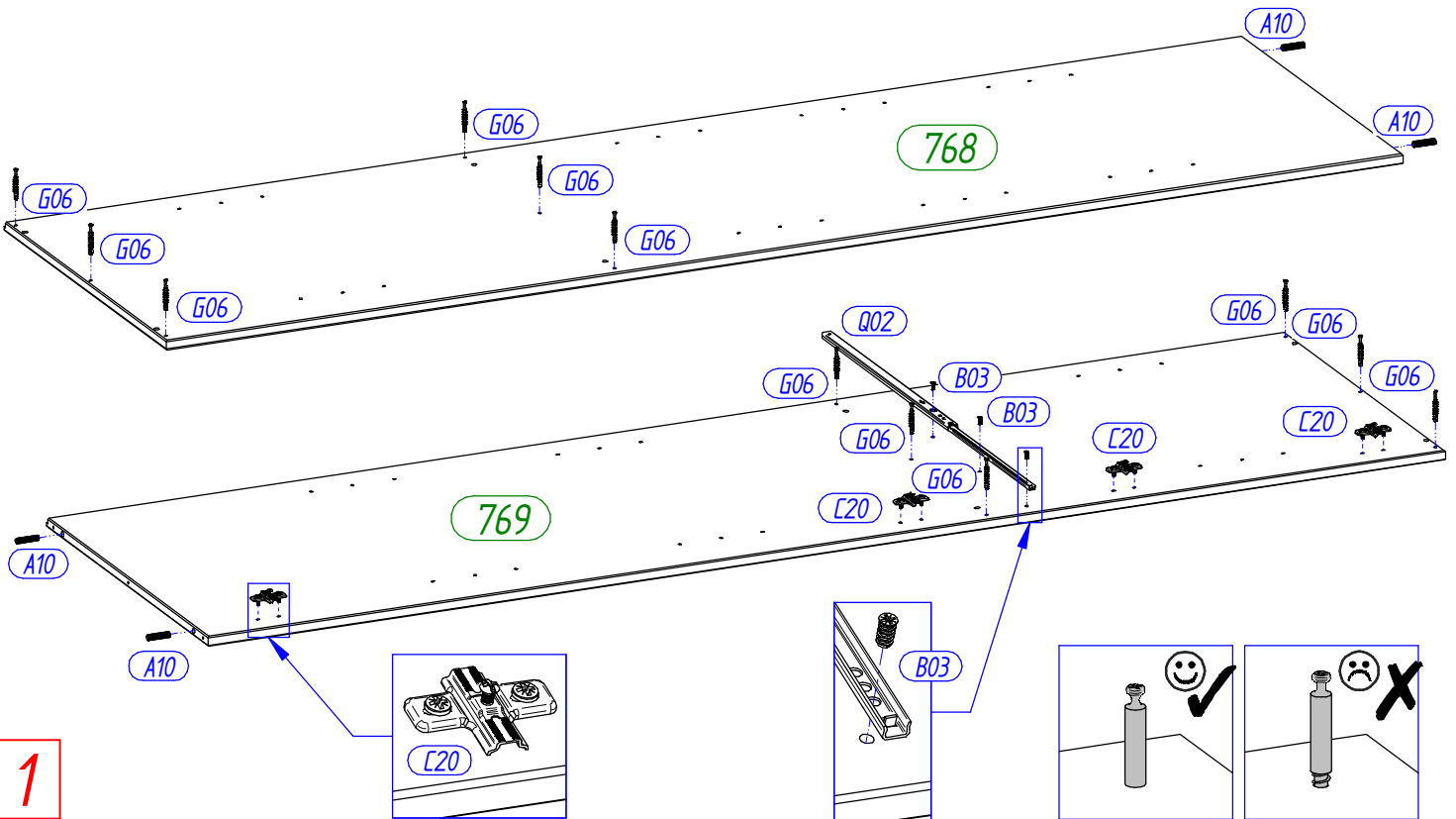

1

<b>A10</b>	4 x	<b>B03</b>	3 x	<b>G08</b>	6 x	<b>G12</b>	3 x	<b>Q02</b>	1 x
Ø8 x 35		Ø5,8 x 11		M4 / 7,0 x 34		M4 x Ø5 x 14		17 x 430	

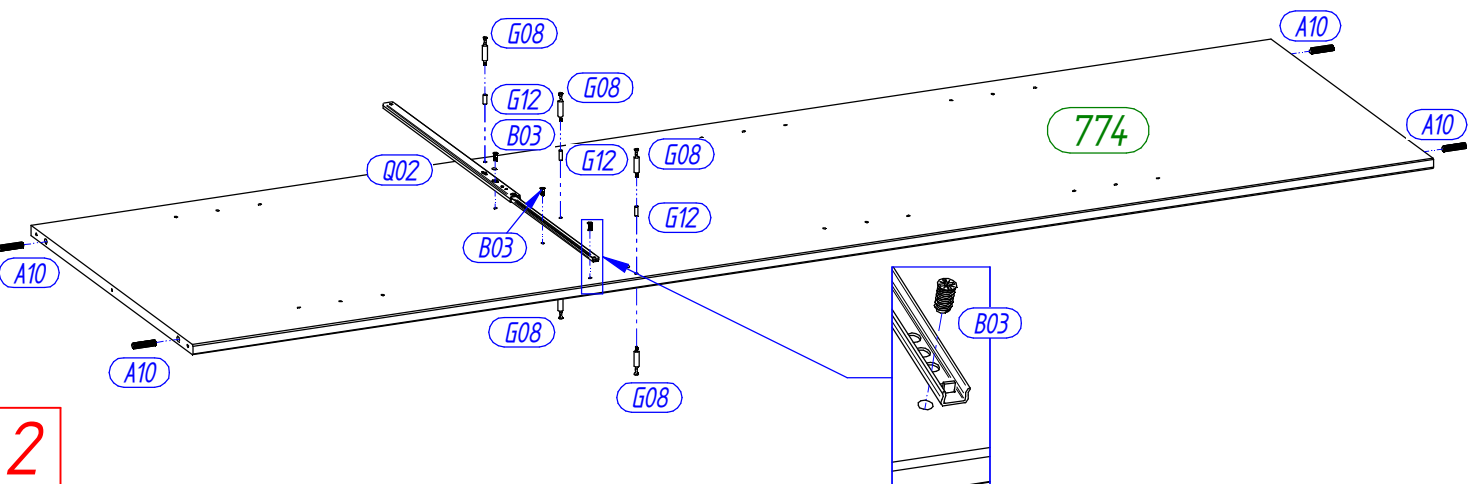

2

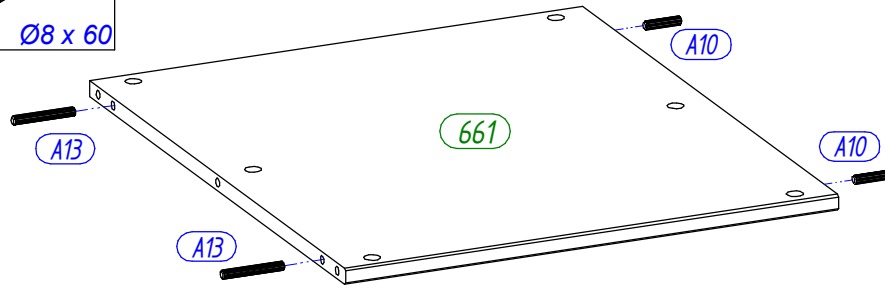
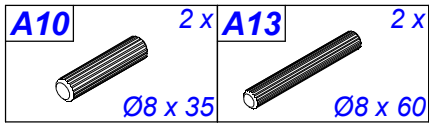

3

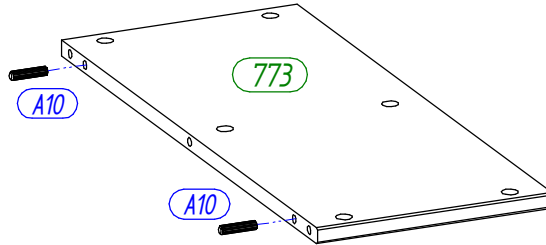
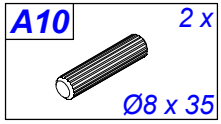

4

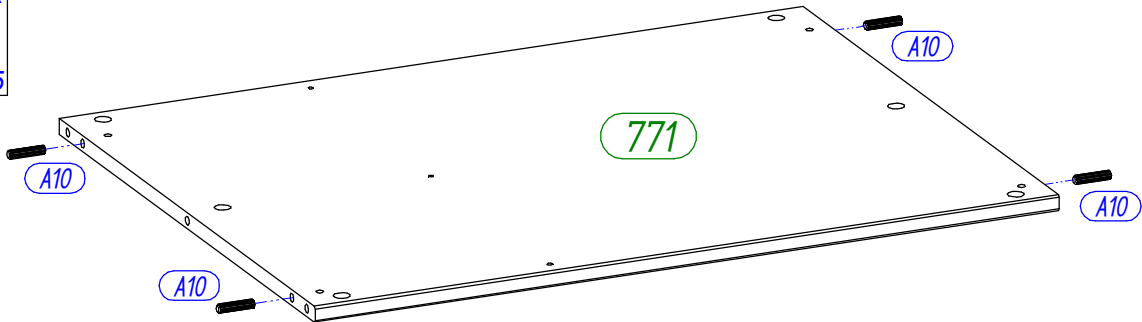
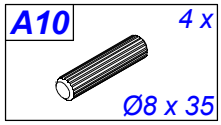

5

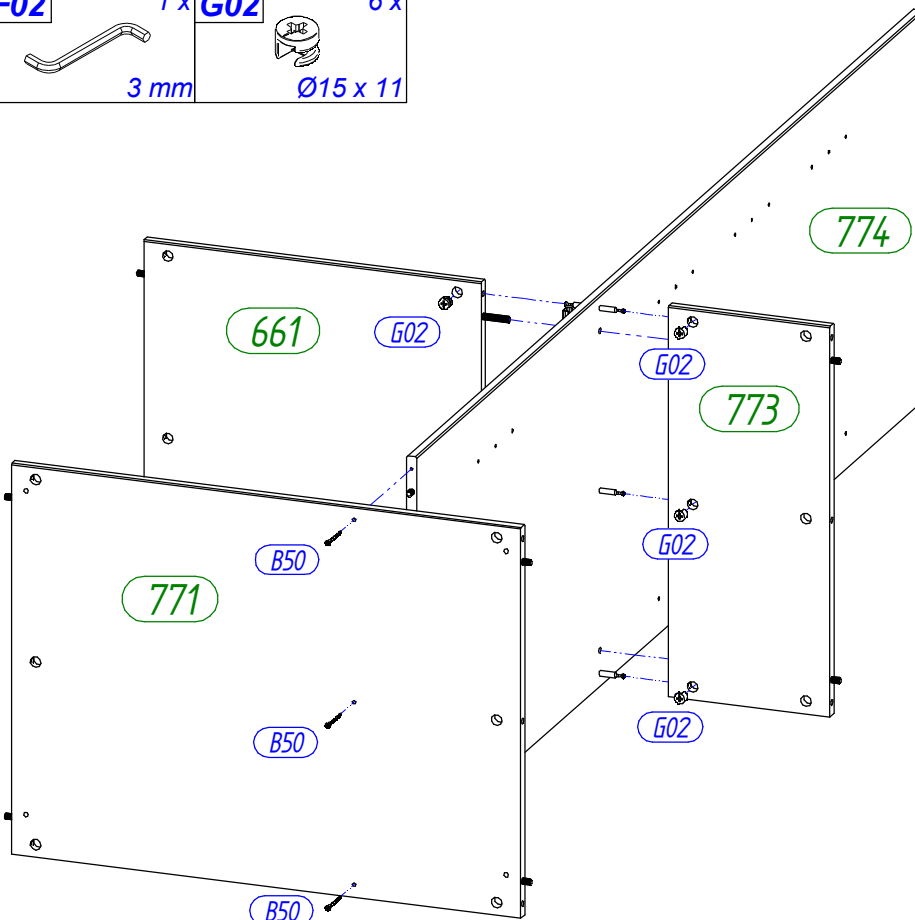
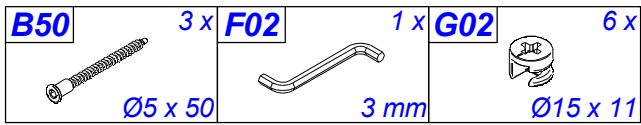

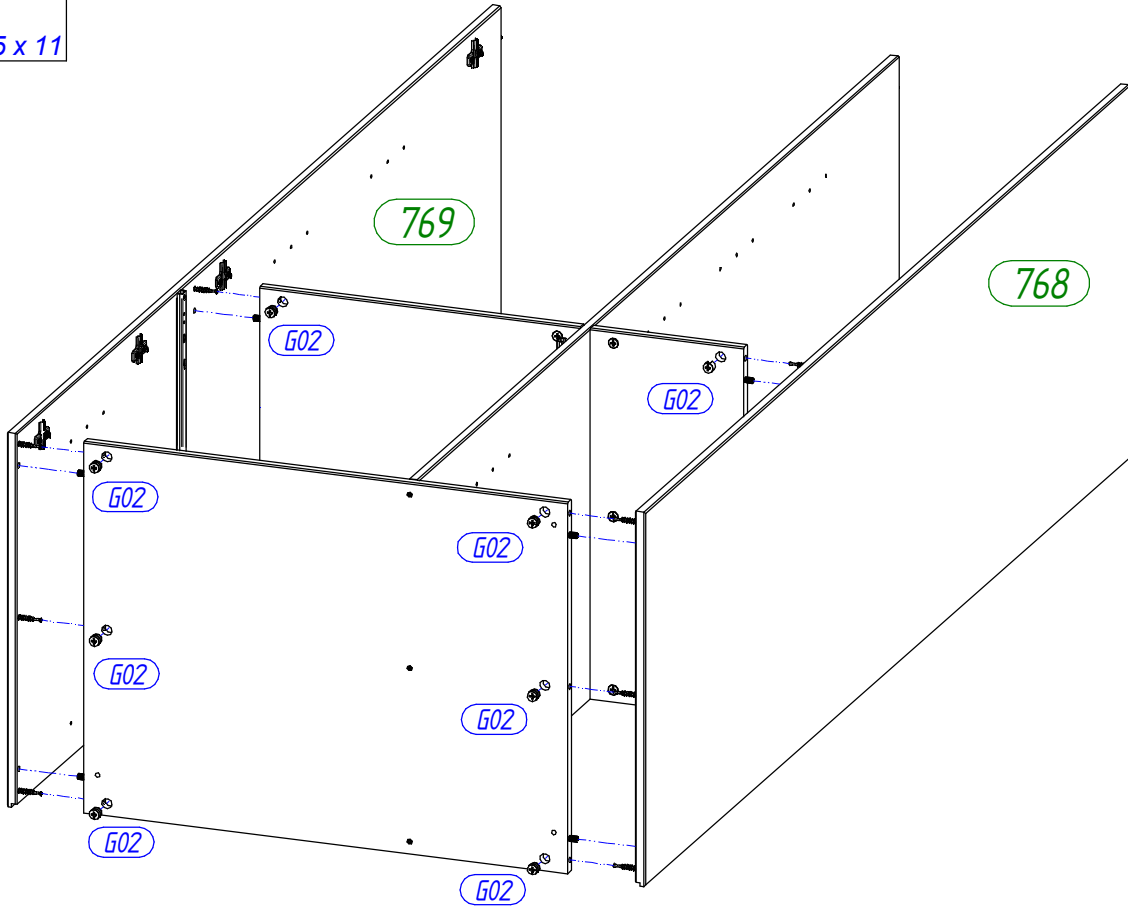

6

<b>G02</b>	12 x
	
	Ø15 x 11

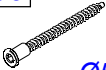
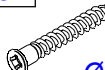
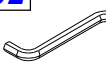

**7**

<b>B50</b>	9 x	<b>B52</b>	4 x
			
	Ø5 x 50		Ø7 x 50
<b>F02</b>	1 x	<b>F04</b>	1 x
			
	3 mm		4 mm

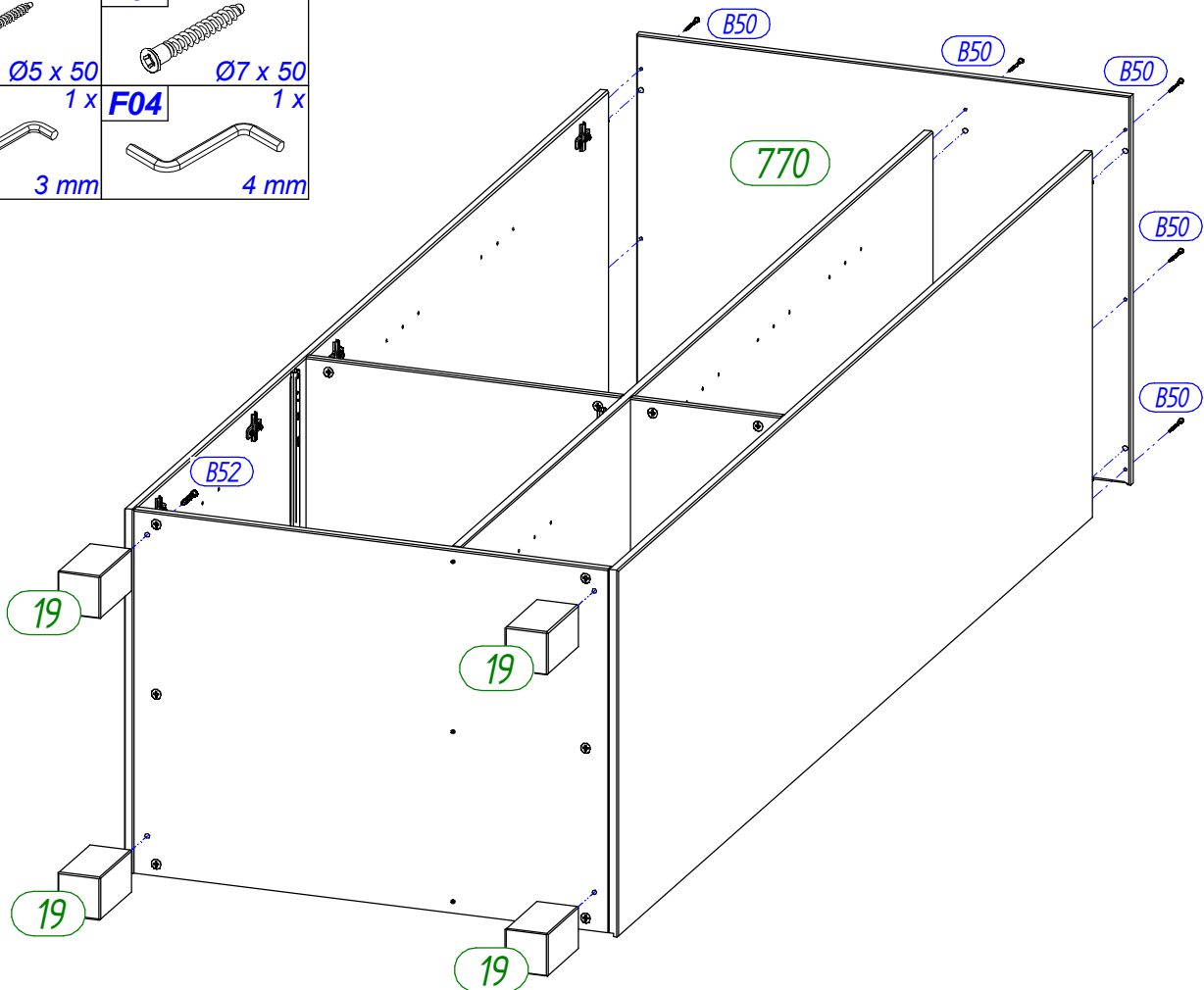

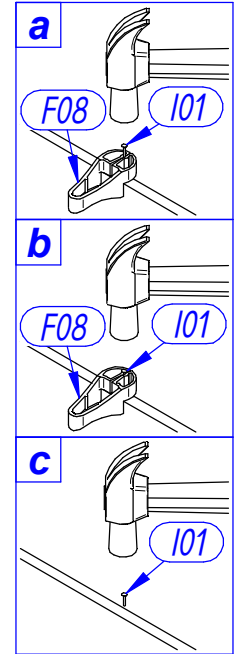
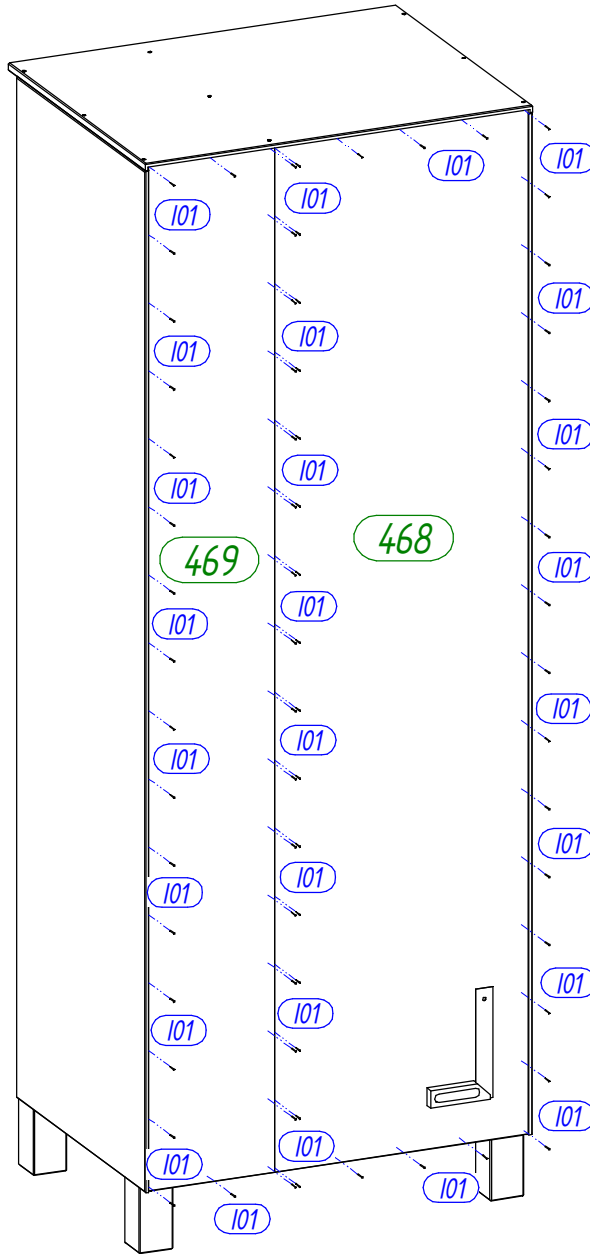
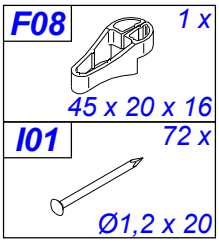

**8**

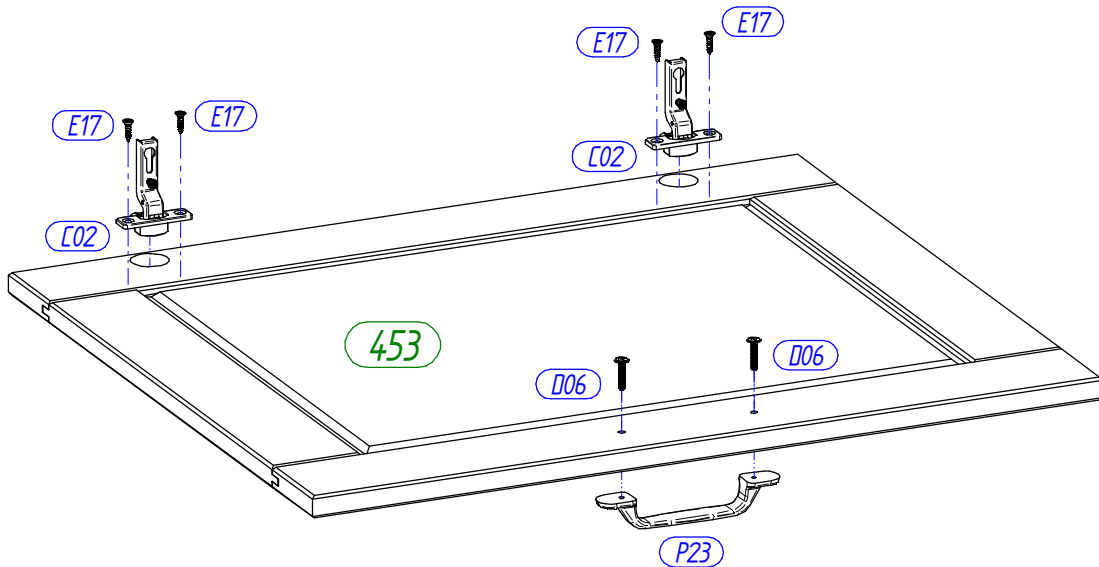
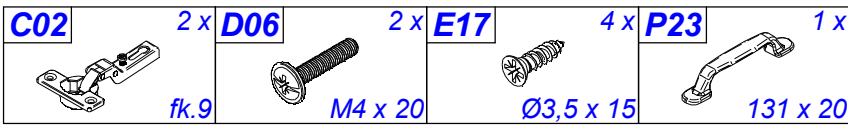

9



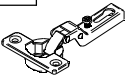

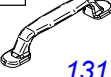

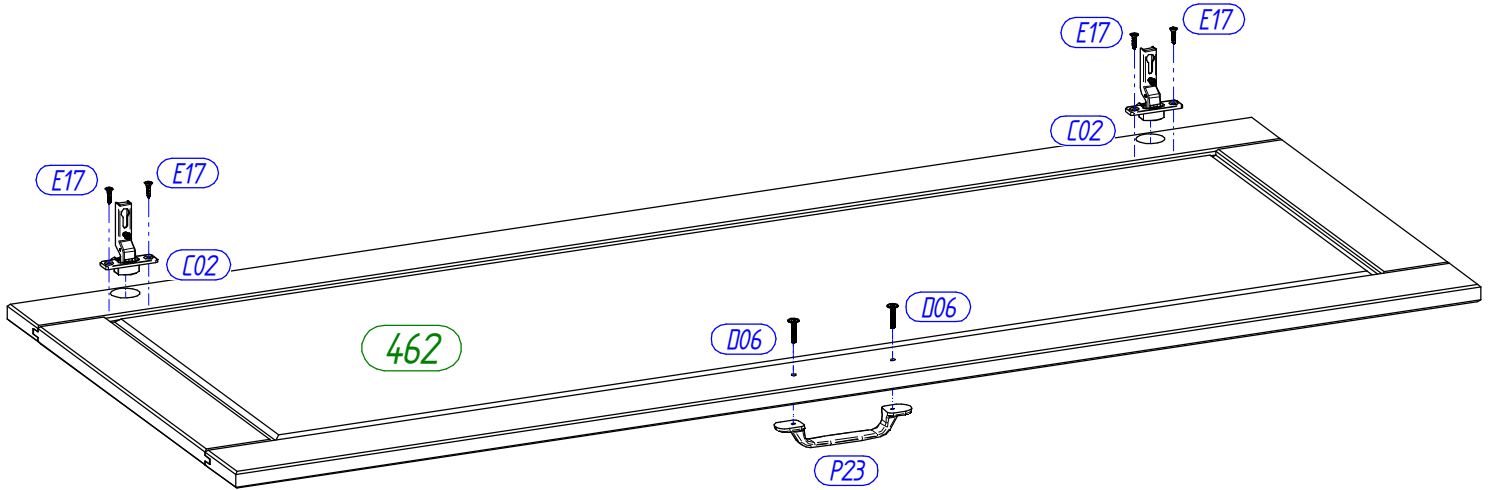
10

<b>C02</b>	2 x	<b>D06</b>	2 x	<b>E17</b>	4 x	<b>P23</b>	1 x
	fk.9		M4 x 20		Ø3,5 x 15		131 x 20

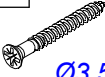

11

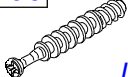
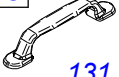
<b>A10</b>	2 x	<b>D06</b>	2 x	<b>E22</b>	4 x	<b>G02</b>	2 x	<b>G06</b>	2 x	<b>P23</b>	1 x
	Ø8 x 35		M4 x 20		Ø3,5 x 35		Ø15 x 11		L - 34		131 x 20

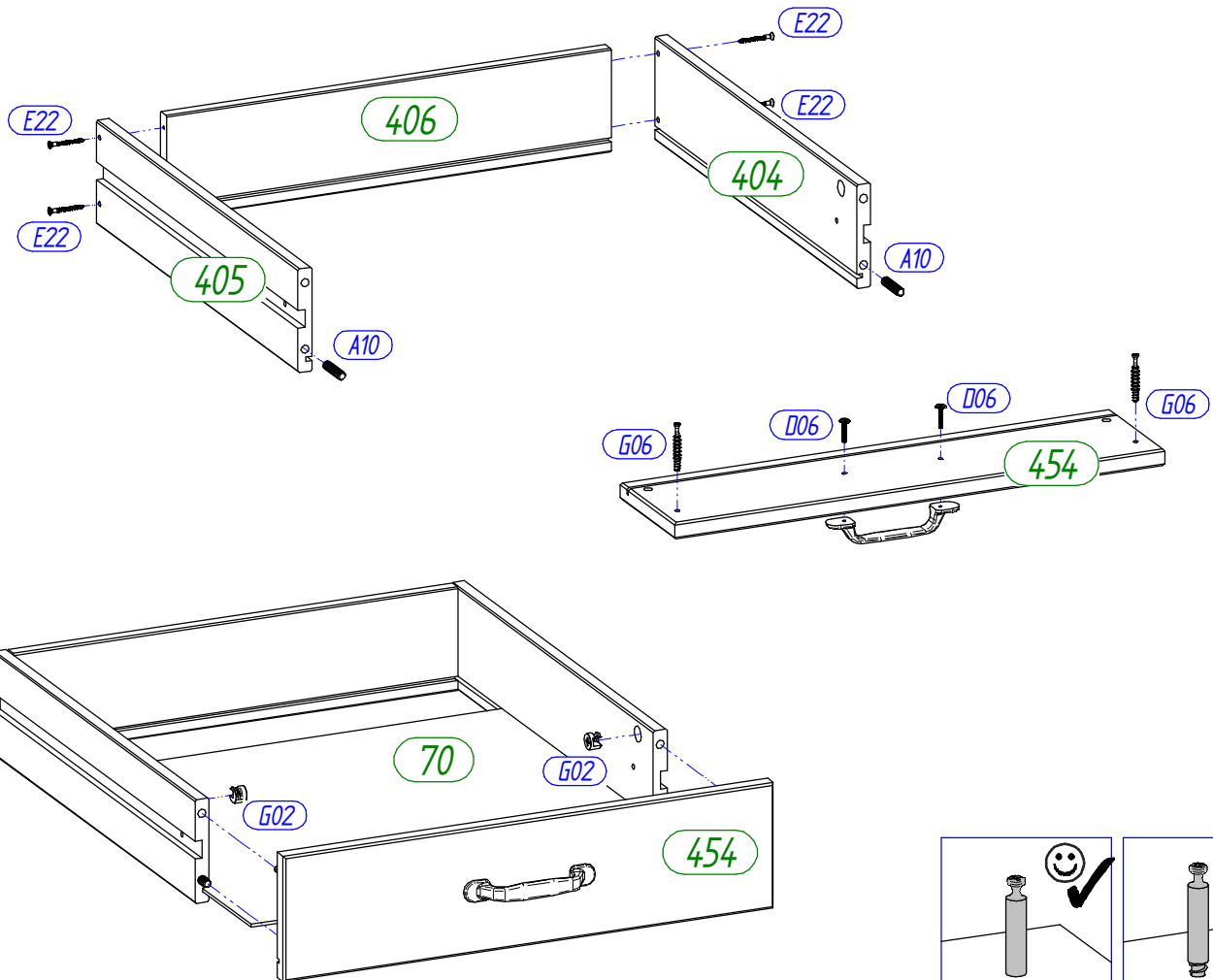

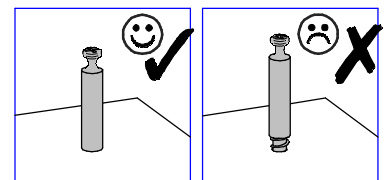

12



**Achtung • Attention • Attenzione • Opgelet • Uwaga • Pozor • Figyelem • Atenție • Dikkat • Внимание**

<b>(D)</b>	Wandbefestigung dient als Kippschutz – unbedingt anbringen! Bei einigen Wandtypen kann ein Spezialdübel erforderlich sein!
<b>(GB)</b>	The wall fastening serves to prevent tipping – be absolutely sure to mount it! For certain wall types, a special dowel may be necessary!
<b>(NL)</b>	Bevestiging aan de muur dient als kantelbescherming – zeker en vast bevestigen! Bij enkele muurtypen is een speciale plug misschien vereist!
<b>(PL)</b>	Mocowanie do ściany jest jednocześnie zabezpieczeniem przed przewróceniem – koniecznie zamontować! Do niektórych rodzajów ścian konieczne mogą być specjalne wkręty!
<b>(TR)</b>	Duvardaki sabitleme, devrilmeye karşı bir emniyet tedbiridir ve mutlaka monte edilmelidir! Bazı duvar tiplerinde bunun için özel bir dübel gerekli olabilir!
<b>(RU)</b>	Обязательно установите крепление на стене во избежание опрокидывания! Для некоторых типов стен может потребоваться специальный дюбель!
<b>(FR)</b>	La fixation murale sert de protection contre le basculement – à installer impérativement ! Pour certains types de murs il faut des chevilles spéciales !
<b>(IT)</b>	Il fissaggio alla parete serve da protezione anti-ribaltamento – attaccarla assolutamente! Per alcune strutture di parete può essere necessario un tassello speciale!
<b>(CZ)</b>	Montáž na stěnu slouží jako ochrana proti převrnutí – bezpodmínečně umístěte! U některých typů stěn může být zapotřebí speciální hmoždinka!
<b>(SK)</b>	Upevnenie na stenu slúži ako ochrana proti prevráteniu – bezpodmienečne použite! Pre niektoré druhy stien môže byť potrebná špeciálna hmoždinka!
<b>(HU)</b>	A terméket a falhoz kel rögzíténi, különben az felborulhat! Egyes faltípusoknál speciális tiplít kell használni!
<b>(RO)</b>	Sistemul de fixare la perete servește ca protecție la răsturnarede montat obligatoriu! Pentru unele tipuri de pereți este posibil să fie necesar un diblu special!

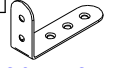
<b>E17</b>	2 x	<b>E38</b>	1 x	<b>K03</b>	1 x
					
Ø3,5 x 15		Ø4,0 x 60		20 x 42 x 70	

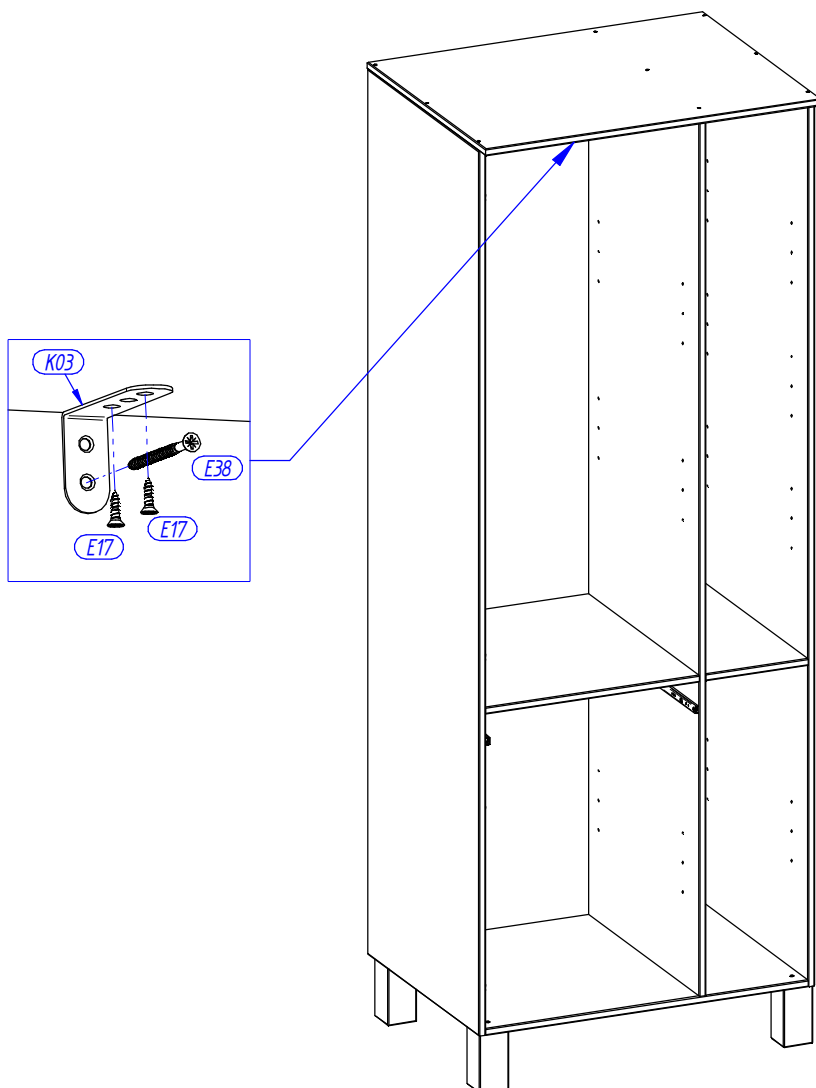

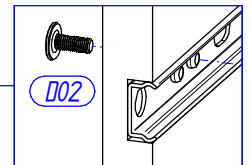
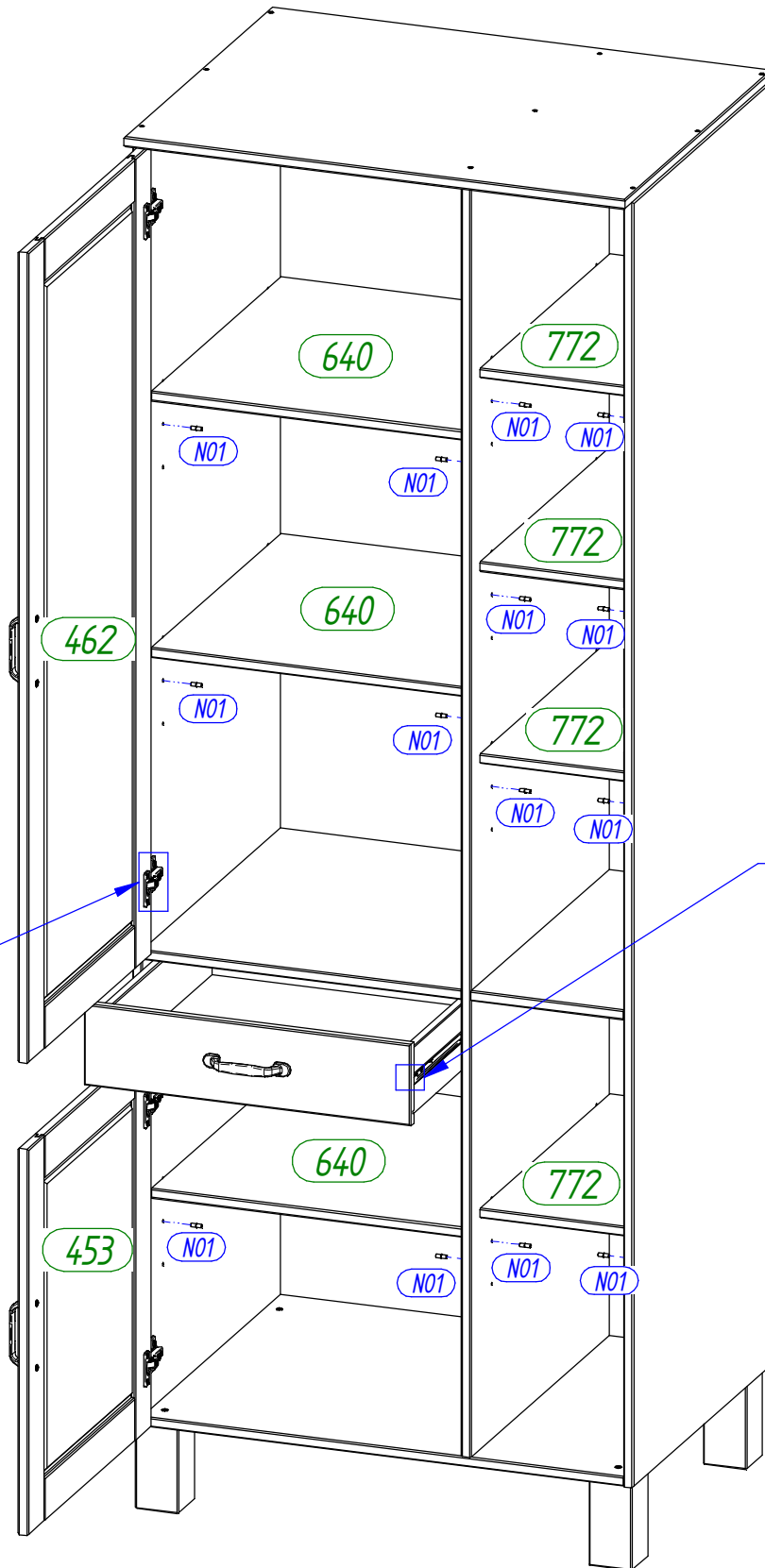
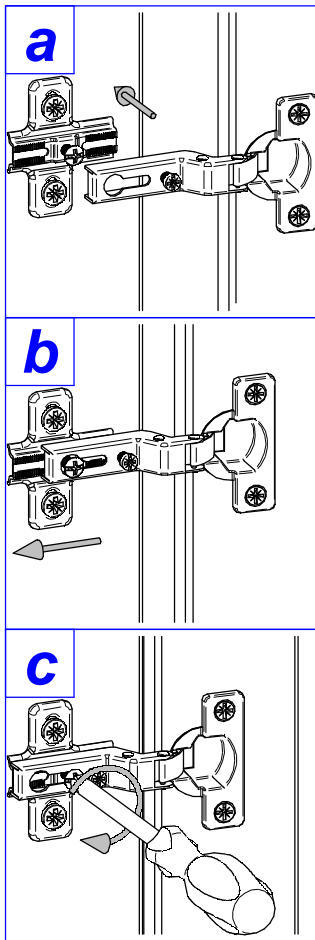
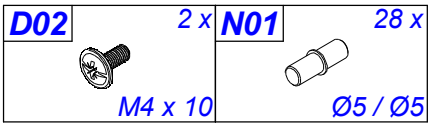

<b>D</b>	Türen einstellen (Scharniere justieren)
<b>GB</b>	Adjusting the doors (adjusting the hinges)
<b>NL</b>	Deuren instellen (scharnieren afstellen)
<b>PL</b>	Nastawić drzwi (wyrównać zawiasy)
<b>TR</b>	Kapıların ayarlanması (menteşelerin seviye ayarı)
<b>RU</b>	Регулировка дверей (регулировка шарнира)
<b>FR</b>	Régler les portes (ajuster les charnières)
<b>IT</b>	Sistemare le porte (regolare le cerniere)
<b>CZ</b>	Vyrovnejte dvířka (seřďte závěsy)
<b>SK</b>	Nastavenie dverí (nastavenie závesov)
<b>HU</b>	Állítsa be az ajtókat (állítsa be a zsanérokat)
<b>RO</b>	Reglare ușii (ajustare balamale)

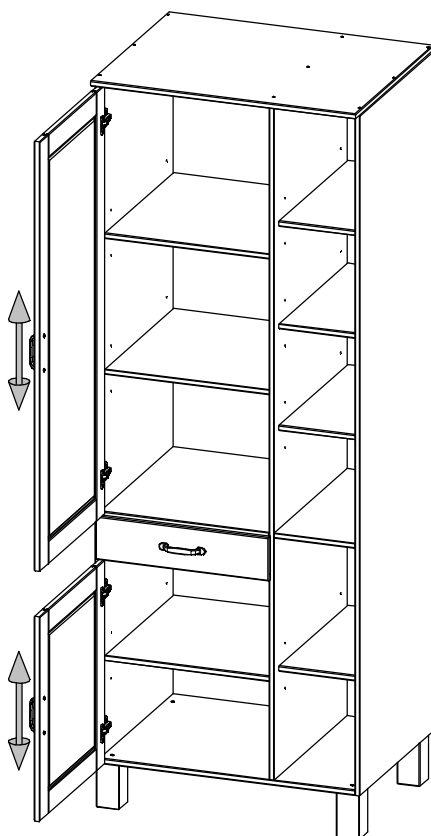
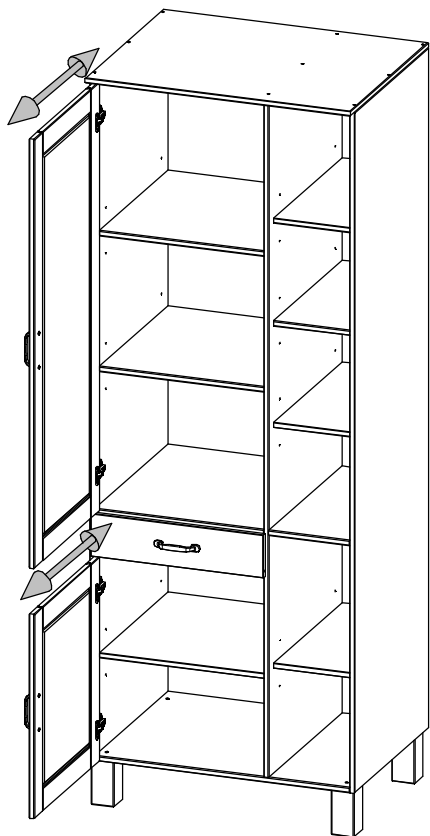
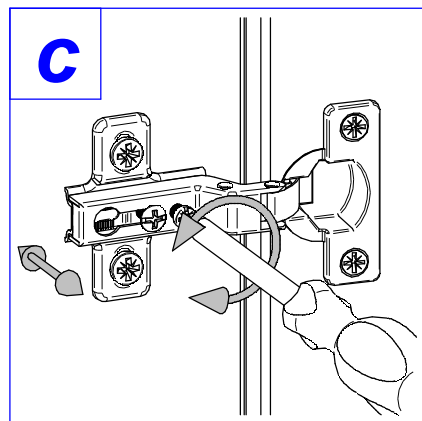
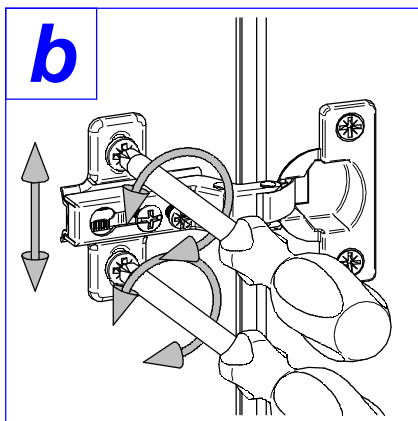
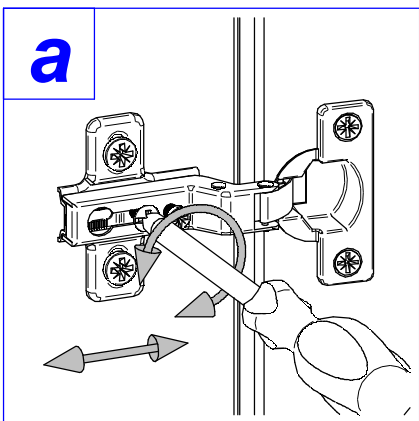



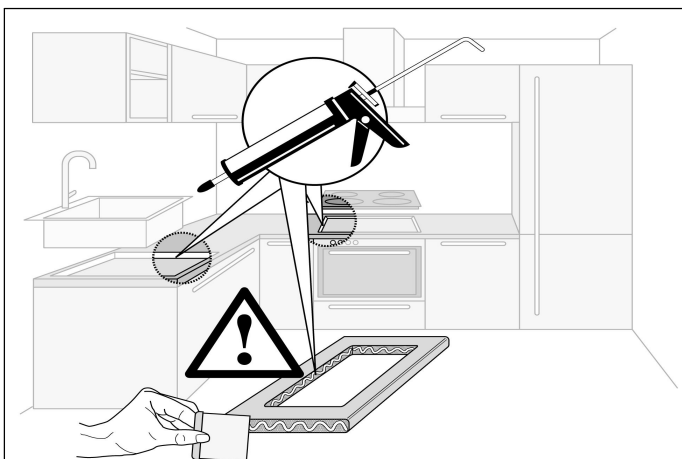
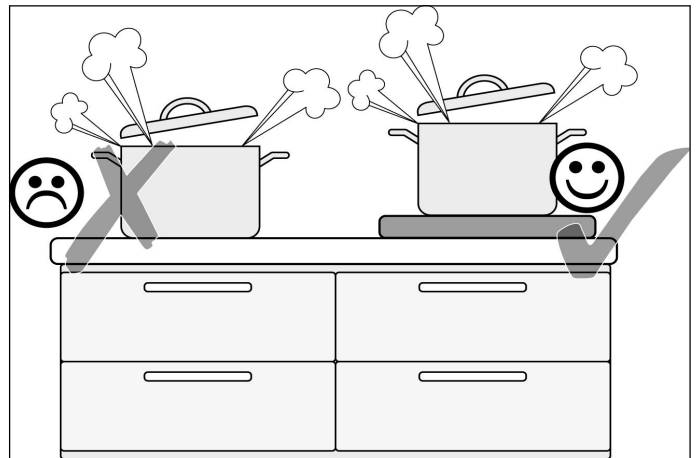
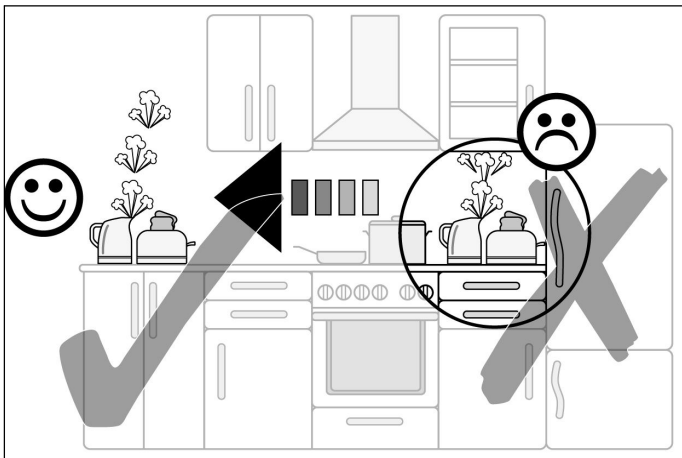
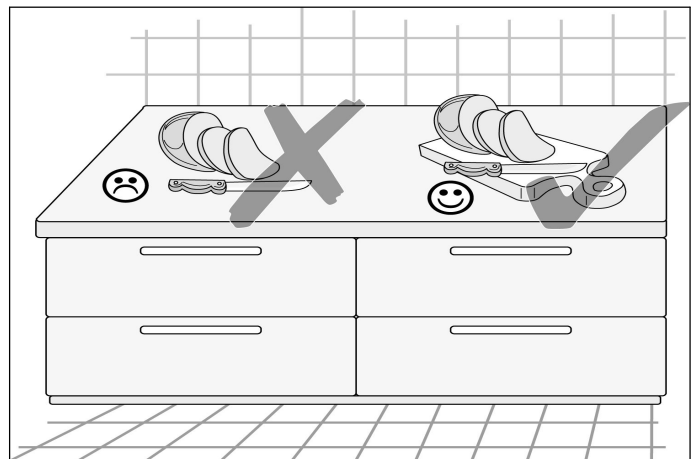
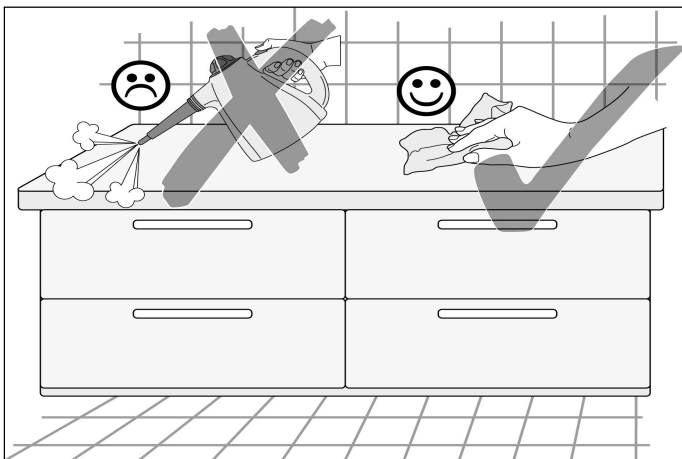
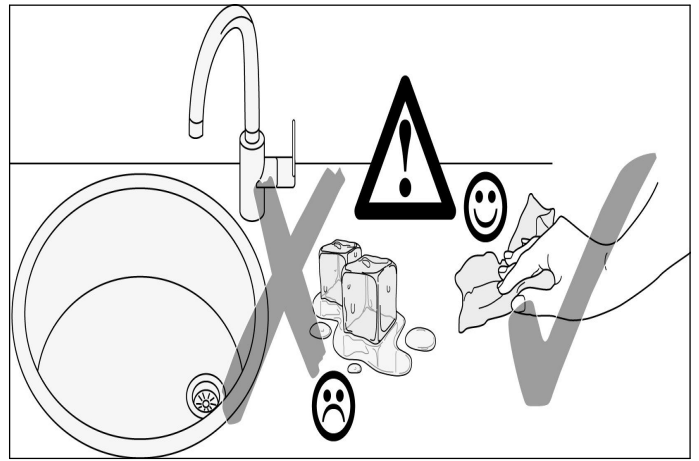
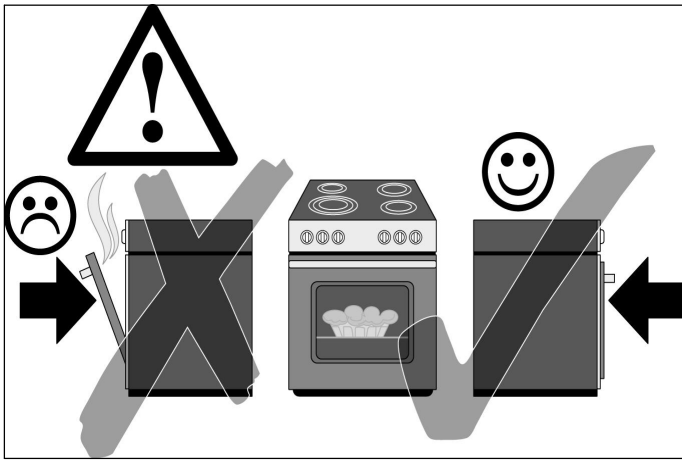

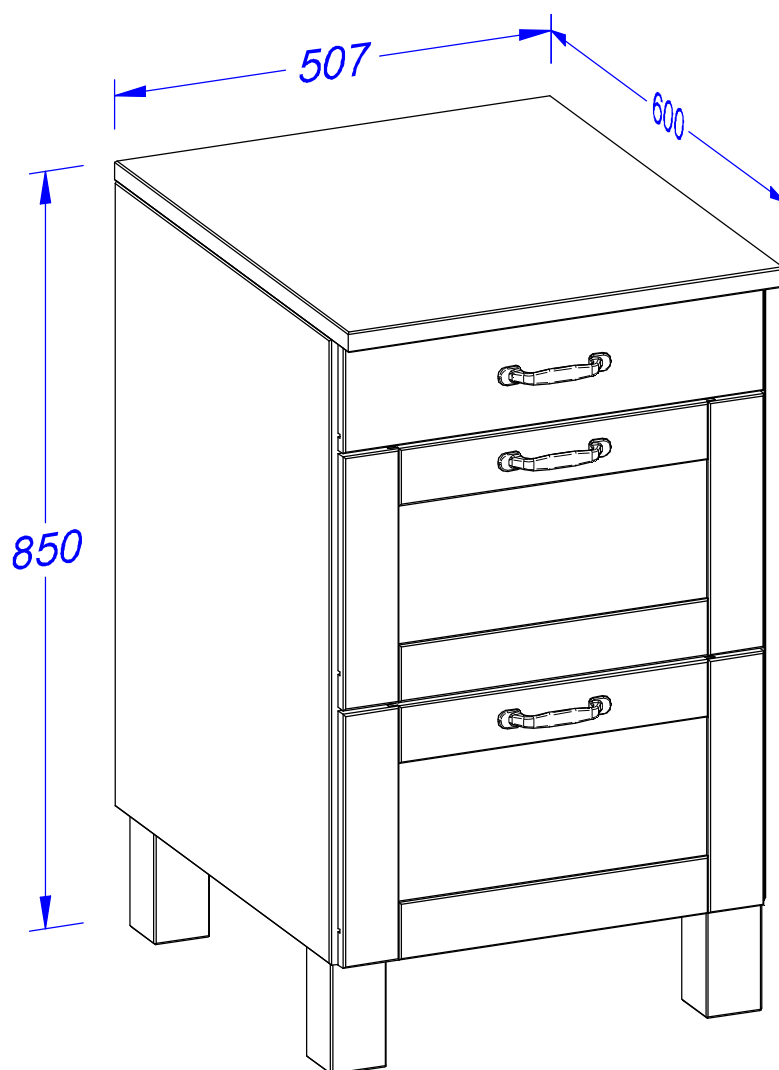

**(D)** *Montageanleitung*

**(NL)** *Handleiding voor de montage*

**(TR)** *Montaj talimatı*

**(FR)** *Notice de montage*

**(CZ)** *Montážní návod*

**(HU)** *Szerelési útmutató*

**(GB)** *Assembly instructions*

**(PL)** *Instrukcja montażu*

**(RU)** *Инструкция по монтажу*

**(IT)** *Istruzioni di montaggio*

**(SK)** *Návod na montáž*









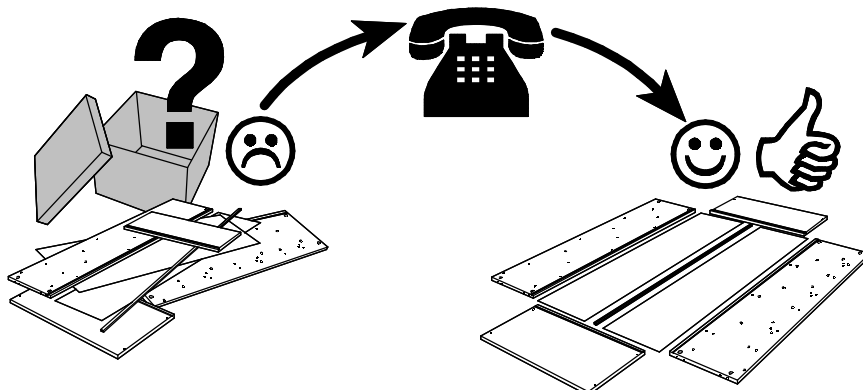
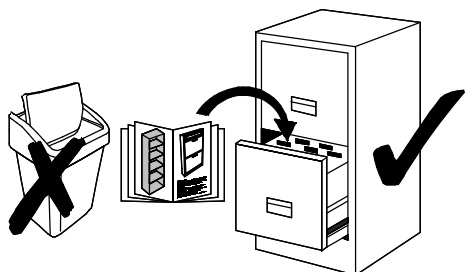

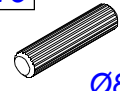

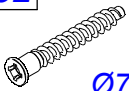
**(RO)** *Instrucțiuni de montaj*

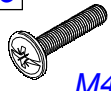
Name • Nom • Nome • Naam • Nazwa • Jméno •  
Názov • Név • Denumire • Isim • Название

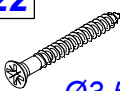
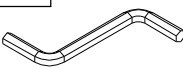
Nr. • No. • N° • Номер • Č • Sz

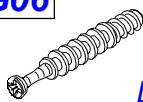
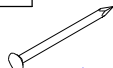
Typ • Type • Tip • Tipus • Tipo • Тип

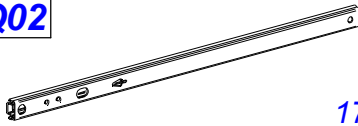
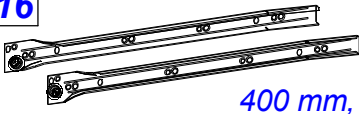

<b>A10</b> 22 x  Ø8 x 35	<b>B01</b> 18 x  Ø5,8 x 8	<b>B52</b> 4 x  Ø7 x 50	<b>D02</b> 2 x  M4 x 10	<b>D06</b> 6 x  M4 x 20	<b>E17</b> 12 x  Ø3,5 x 15
<b>E22</b> 16 x  Ø3,5 x 35	<b>F04</b> 1 x  4 mm	<b>F08</b> 1 x  45 x 20 x 16	<b>G02</b> 20 x  Ø15 x 11	<b>G06</b> 20 x  L - 34	<b>I01</b> 25 x  Ø1,2 x 20
<b>P23</b> 3 x  131 x 20	<b>Q02</b> 2 x  17 x 430		<b>Q16</b> 2 x  400 mm, L + R		
<b>Q17</b> 2 x  400 mm, L + R					

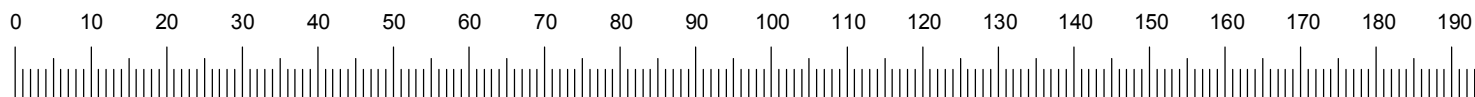
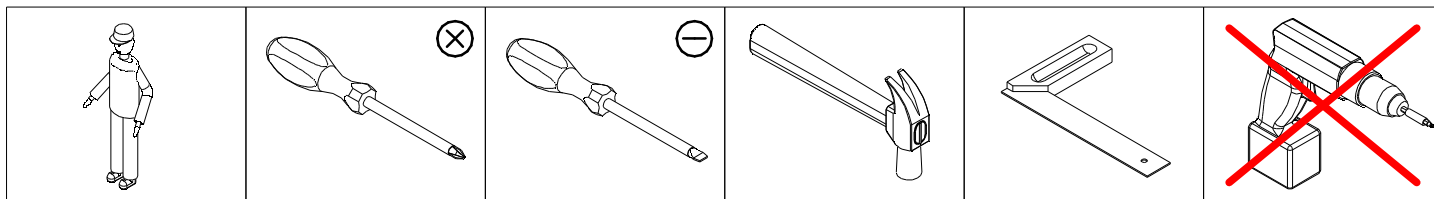

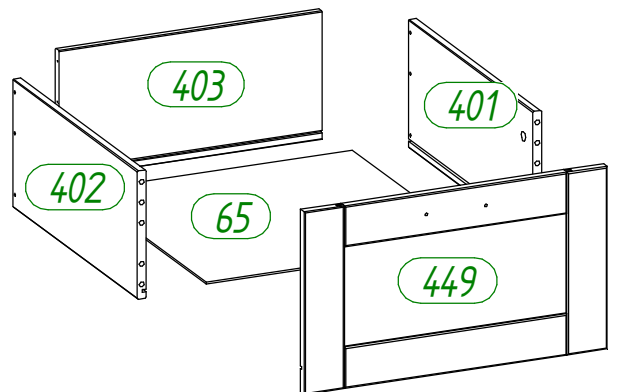
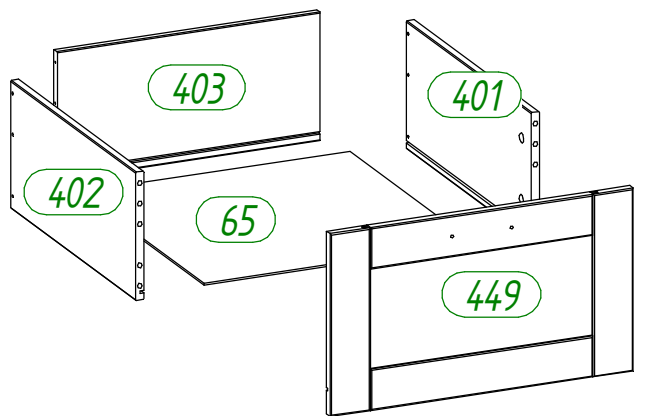
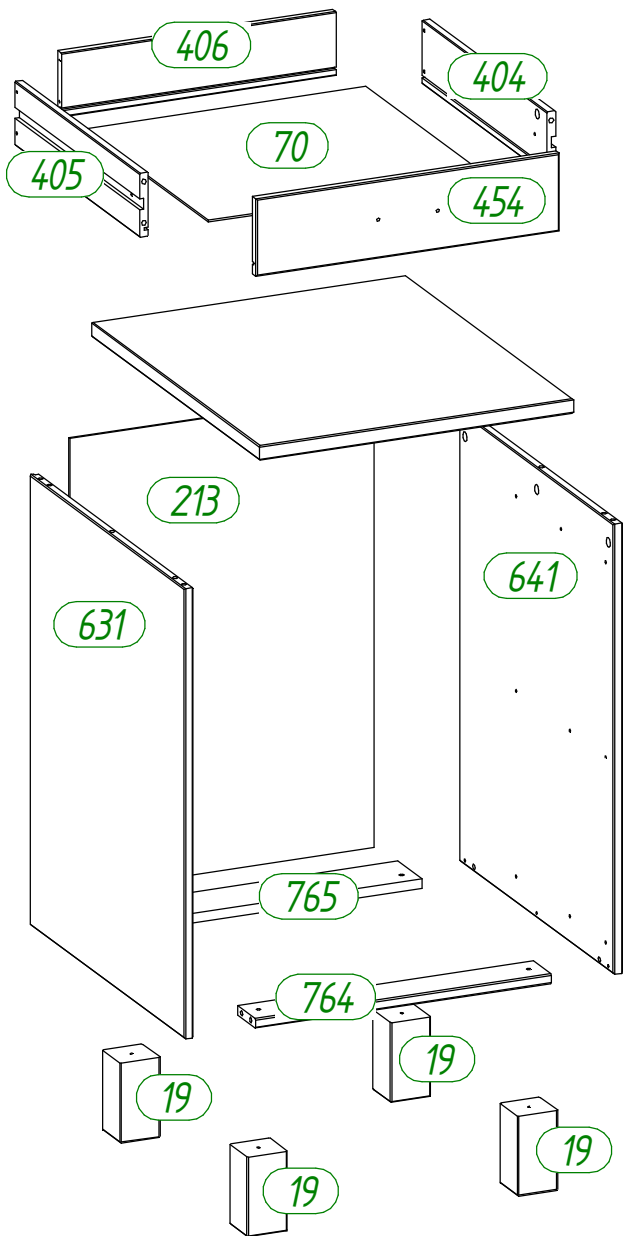

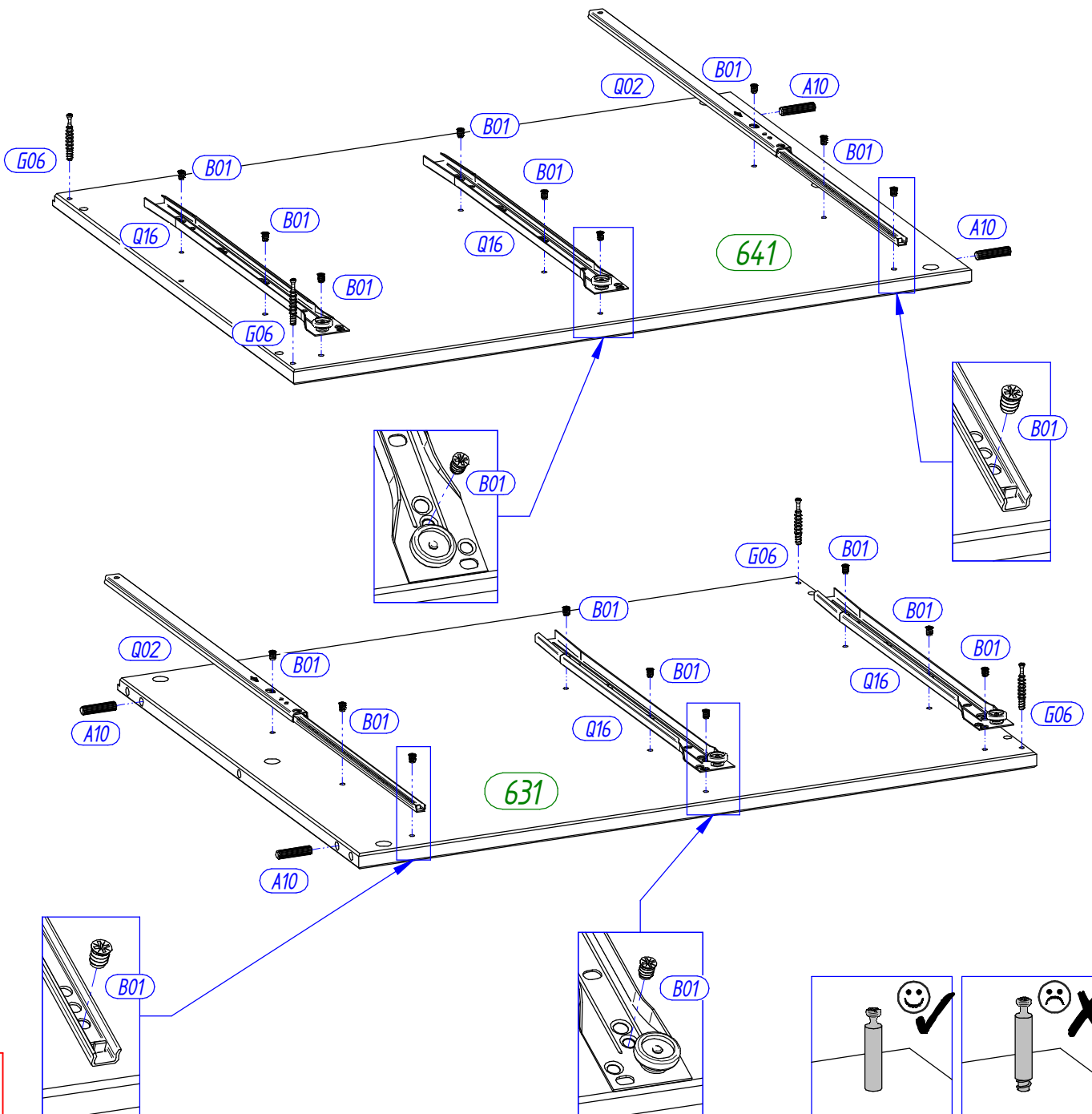
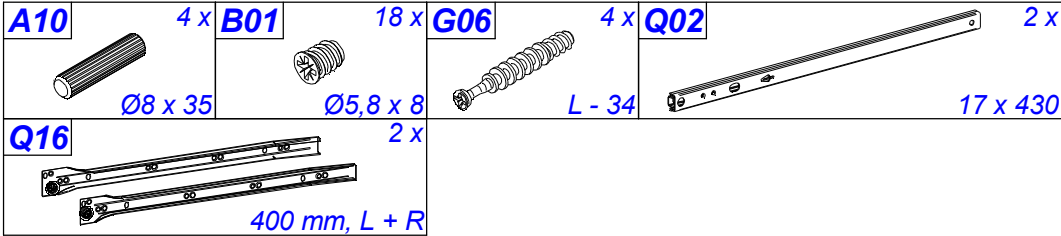
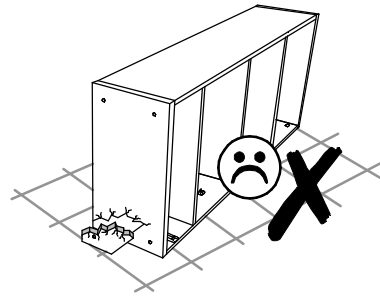
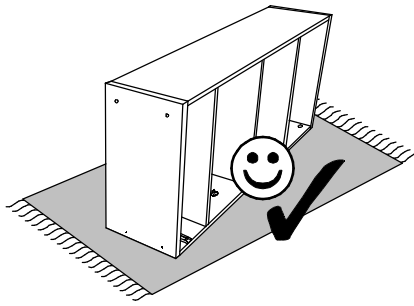

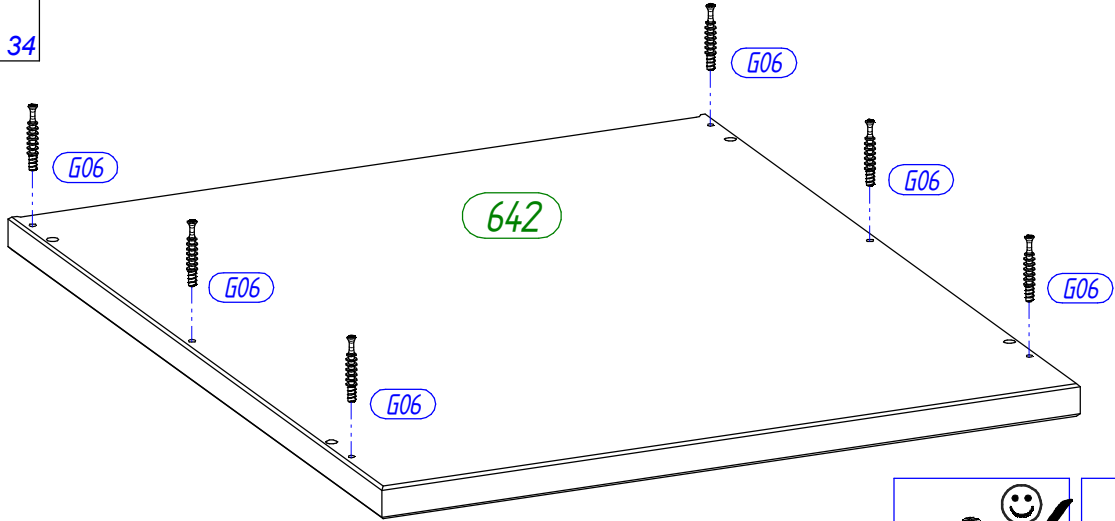
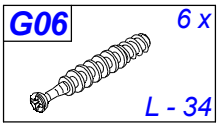

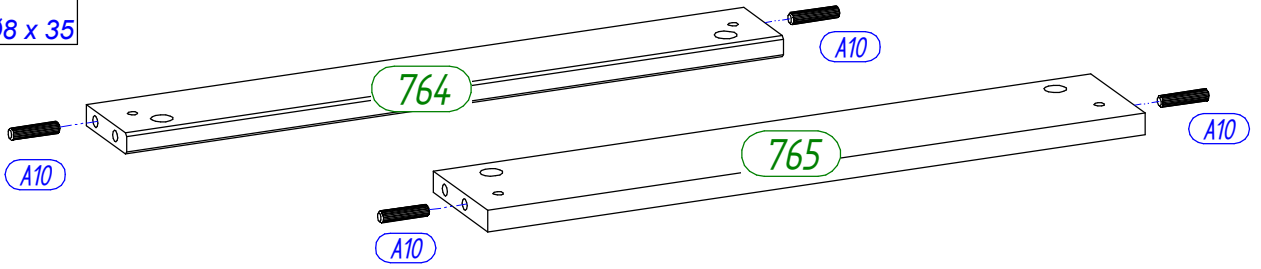
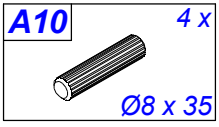
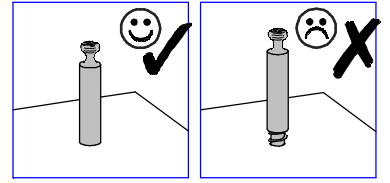

2

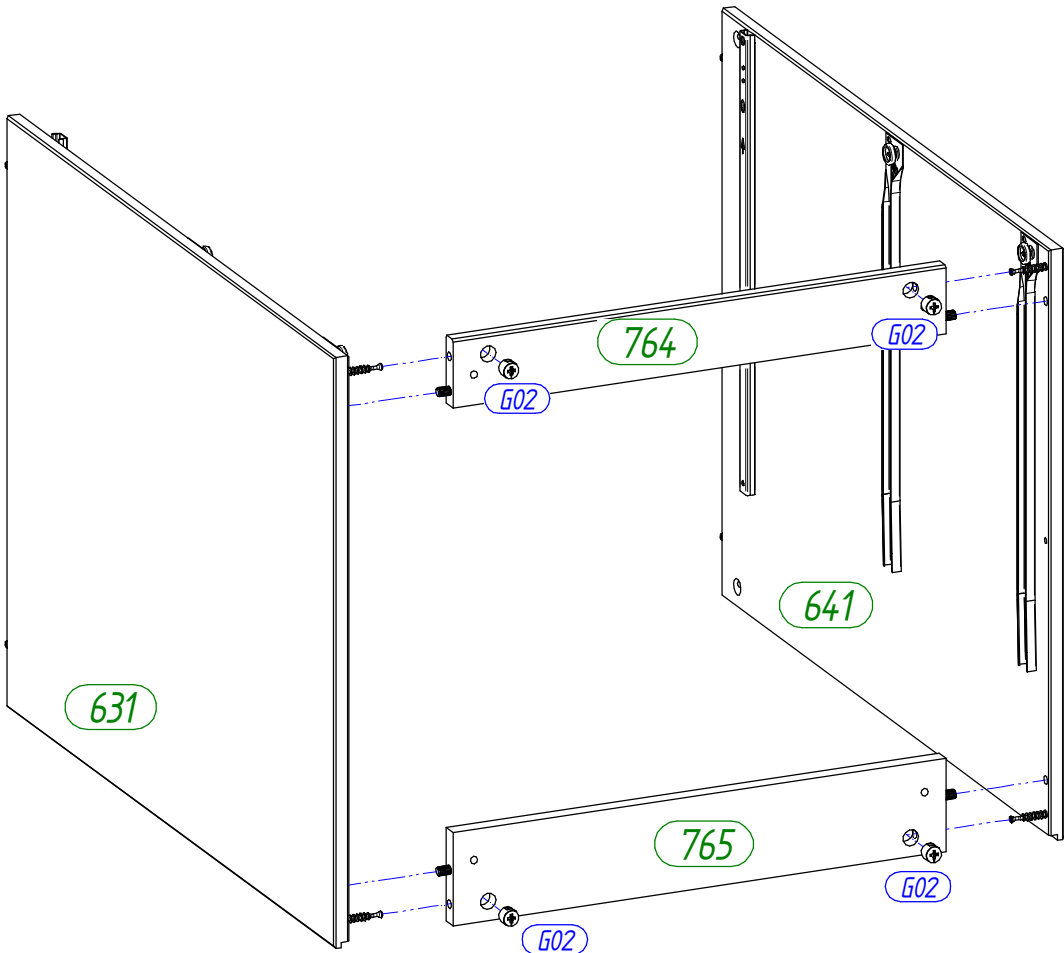
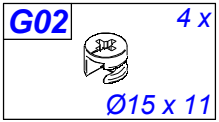

3

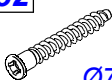
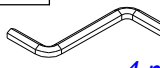

4

<b>B52</b>	4 x
	$\varnothing 7 \times 50$
<b>F04</b>	1 x
	4 mm
<b>G02</b>	6 x
	$\varnothing 15 \times 11$

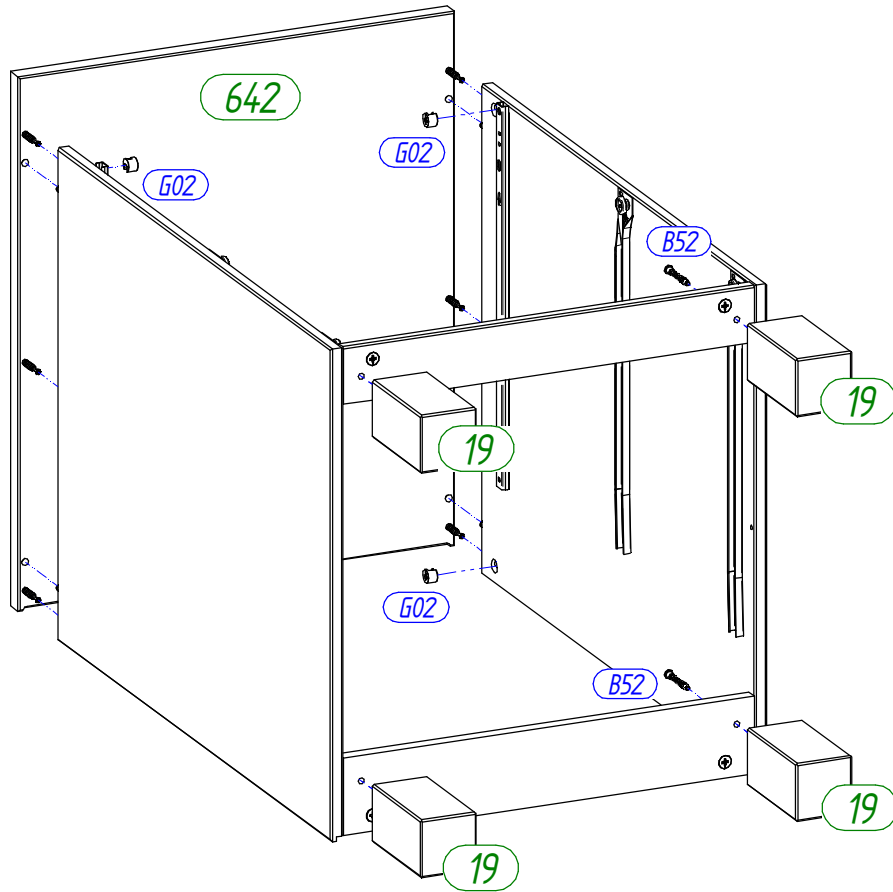



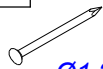

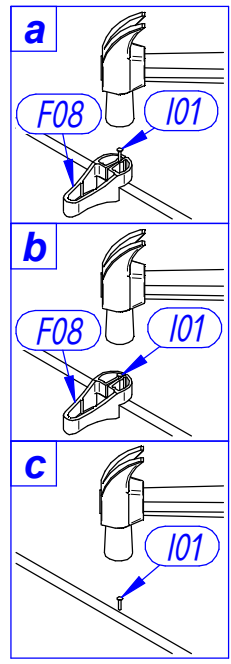
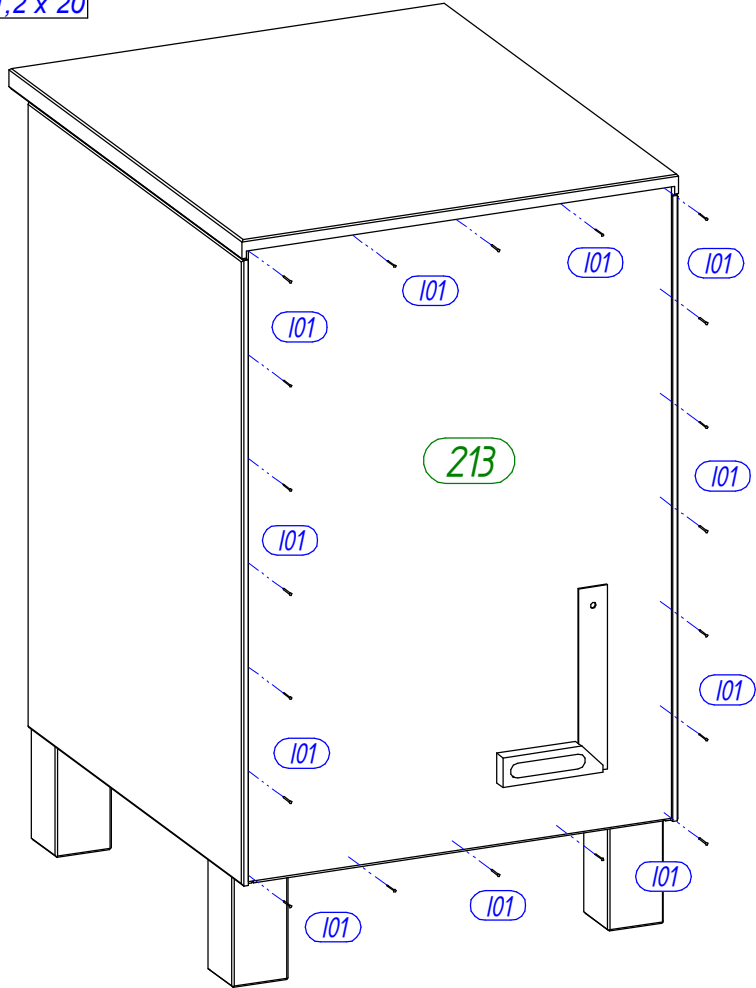

5

<b>F08</b>	1 x	<b>I01</b>	20 x
	$45 \times 20 \times 16$		$\varnothing 1,2 \times 20$



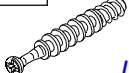



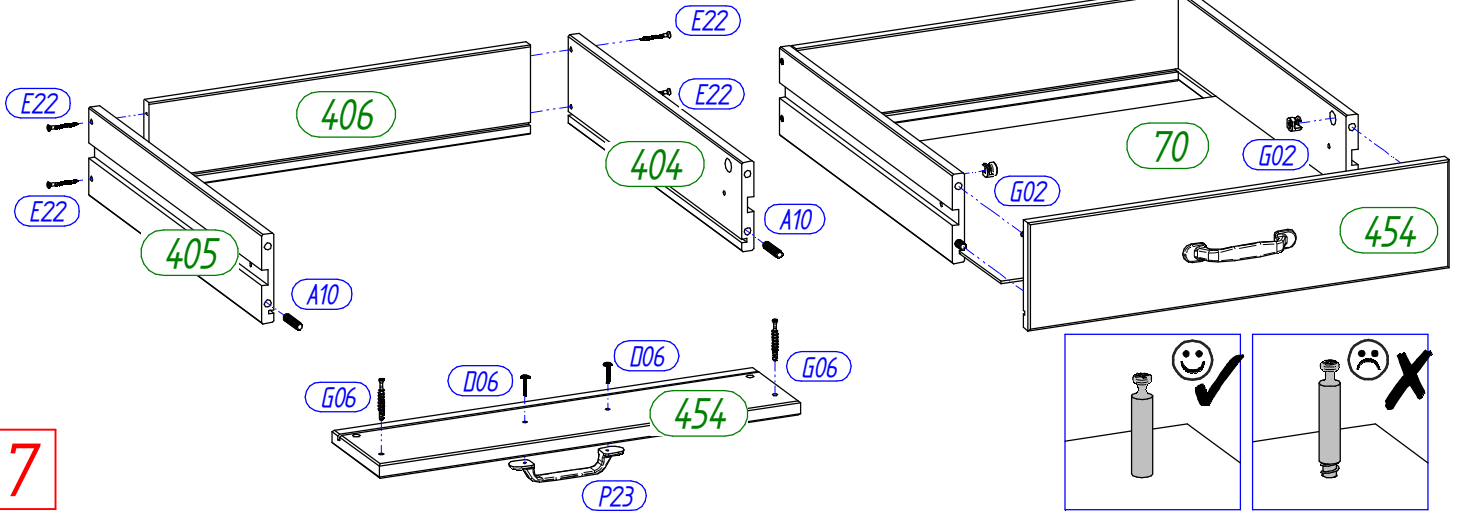

6

<b>A10</b>	2 x	<b>D06</b>	2 x	<b>E22</b>	4 x	<b>G02</b>	2 x	<b>G06</b>	2 x	<b>P23</b>	1 x
											
		Ø8 x 35		M4 x 20		Ø3,5 x 35		Ø15 x 11		L - 34	131 x 20

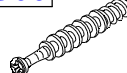
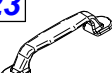

7

<b>A10</b>	12 x	<b>D06</b>	4 x	<b>E17</b>	12 x	<b>E22</b>	12 x	<b>G02</b>	8 x	<b>G06</b>	8 x
											
		Ø8 x 35		M4 x 20		Ø3,5 x 15		Ø3,5 x 35		Ø15 x 11	L - 34
<b>P23</b>	2 x	<b>Q17</b>	2 x								
											
		131 x 20	400 mm, L + R								

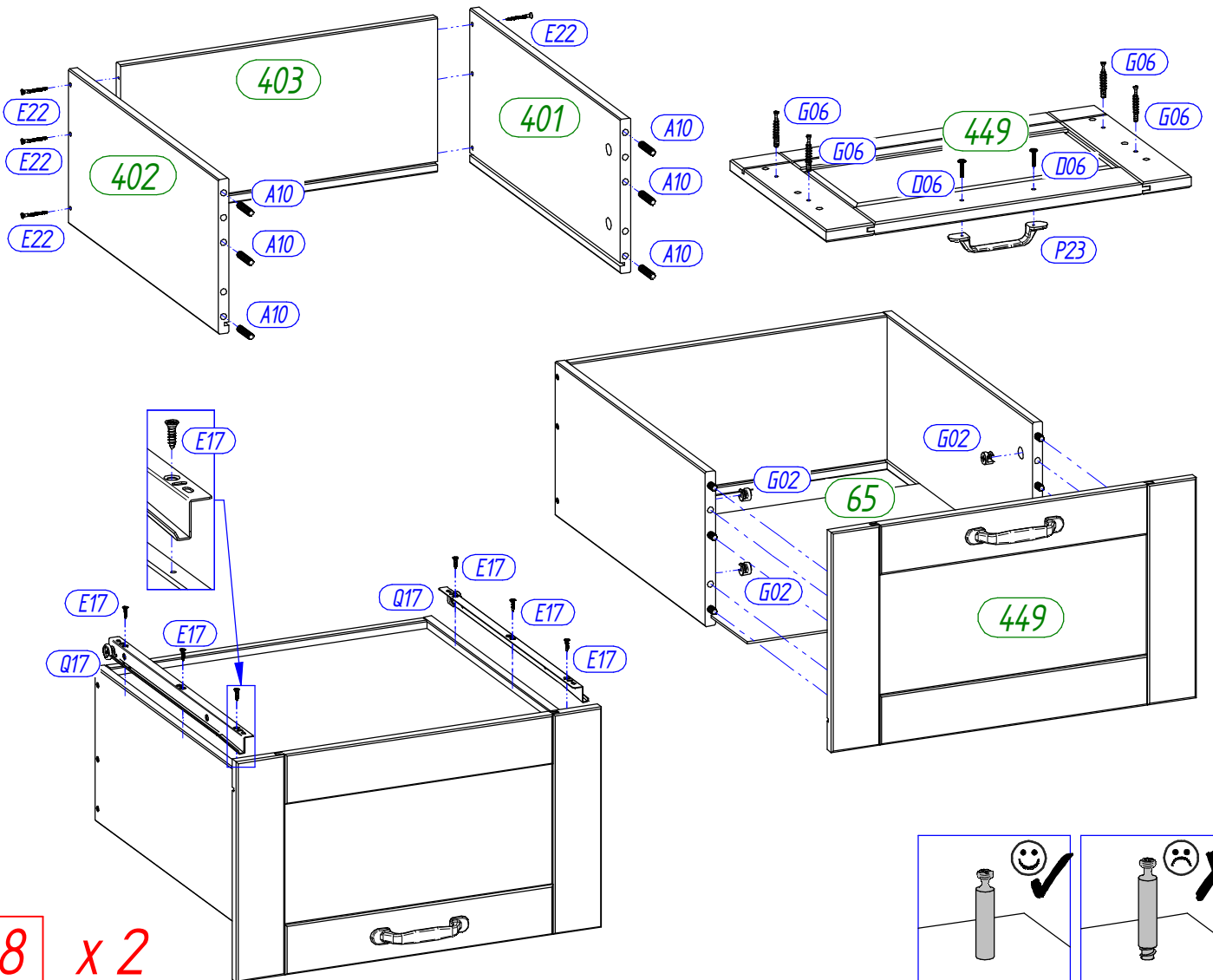

8 x 2



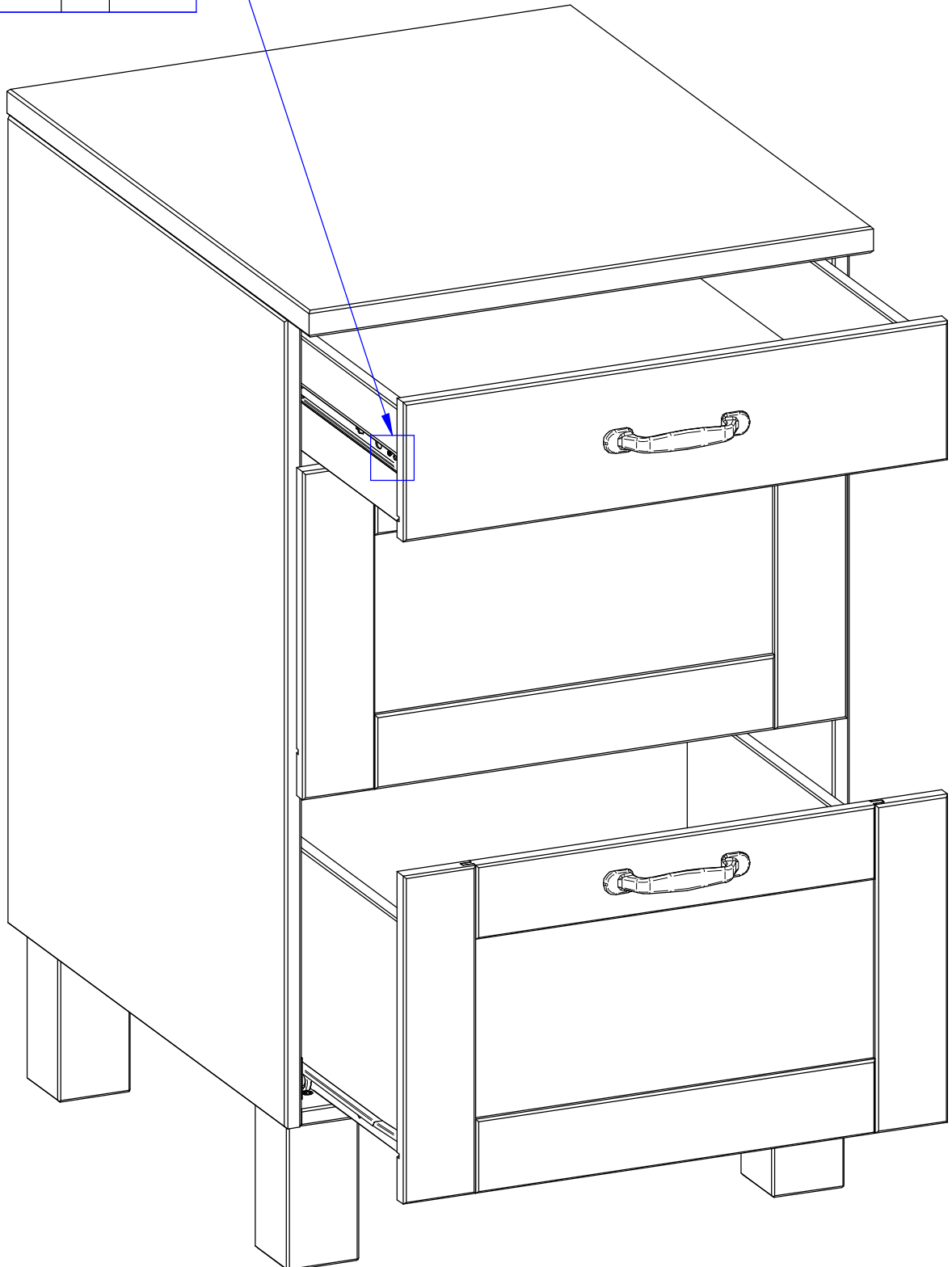
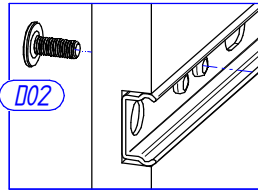
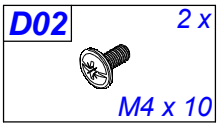

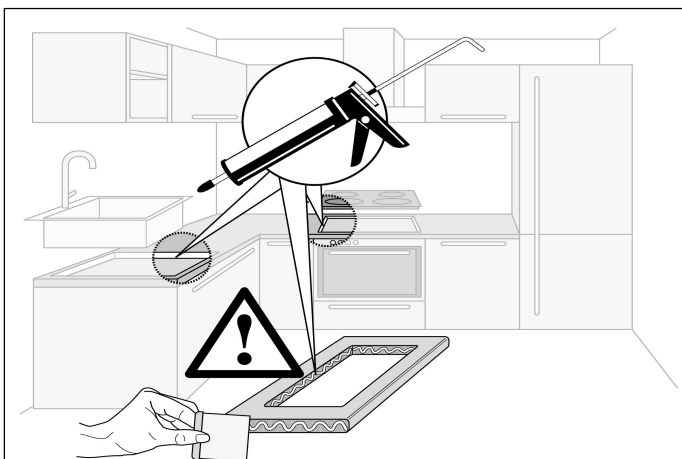
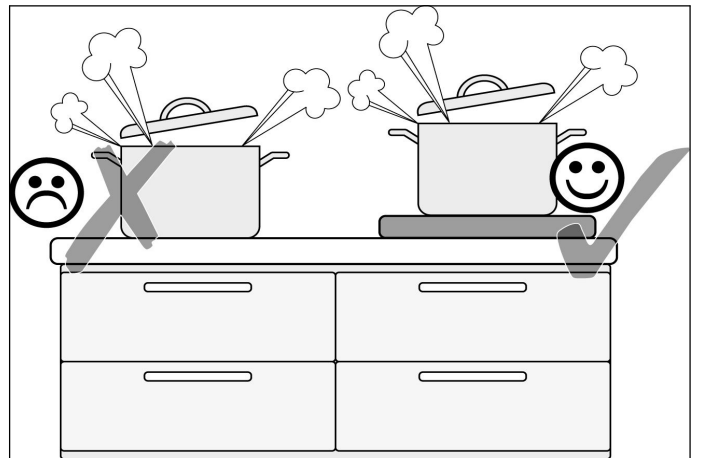
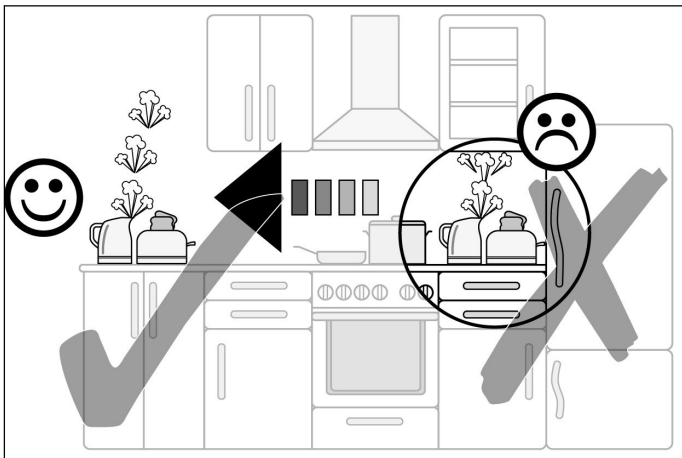
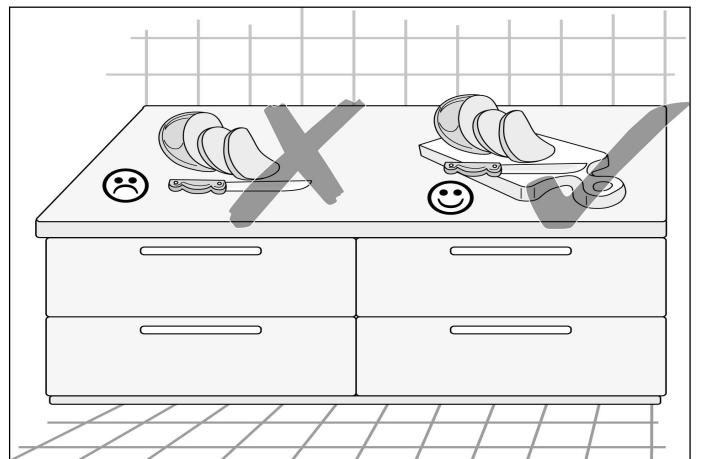
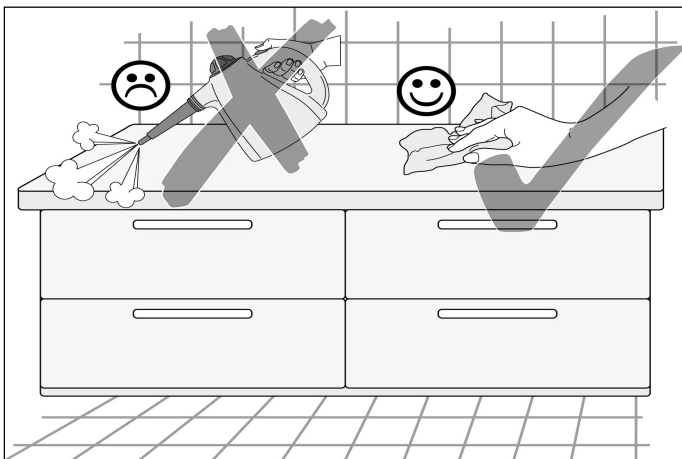
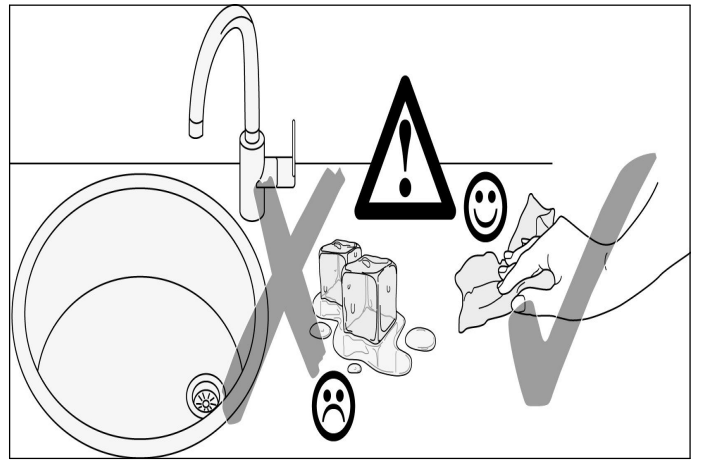
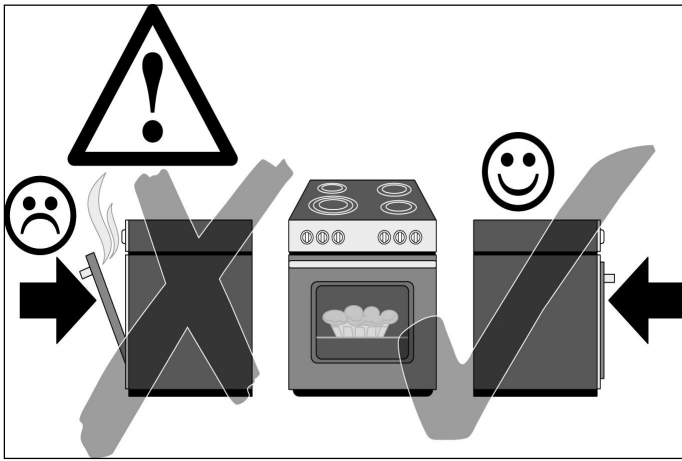

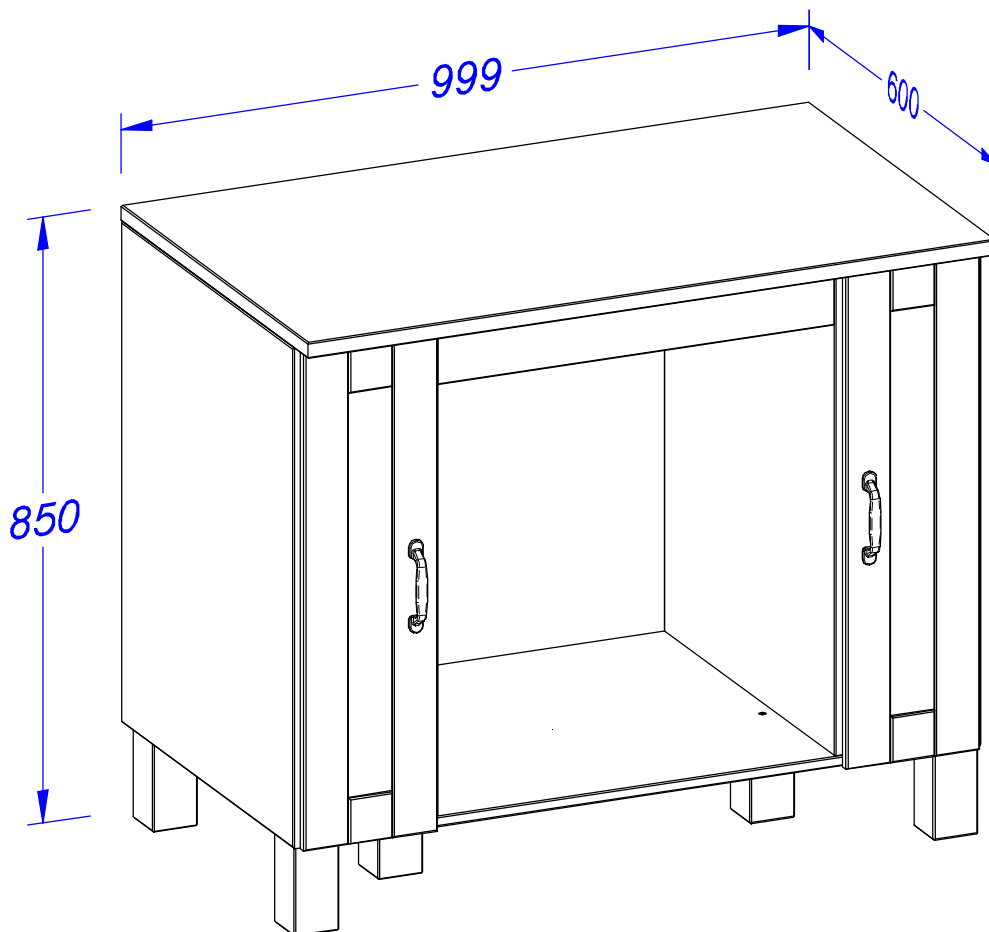

**(D)** *Montageanleitung*

**(NL)** *Handleiding voor de montage*

**(TR)** *Montaj talimatı*

**(FR)** *Notice de montage*

**(CZ)** *Montážní návod*

**(HU)** *Szerelési útmutató*

**(GB)** *Assembly instructions*

**(PL)** *Instrukcja montażu*

**(RU)** *Инструкция по монтажу*

**(IT)** *Istruzioni di montaggio*

**(SK)** *Návod na montáž*

**(RO)** *Instrucțiuni de montaj*

Name • Nom • Nome • Naam • Nazwa • Jméno •  
Názov • Név • Denumire • Isim • Название

Nr. • No. • N° • Номер • Č • Sz

Typ • Type • Tip • Típus • Tipo • Тип

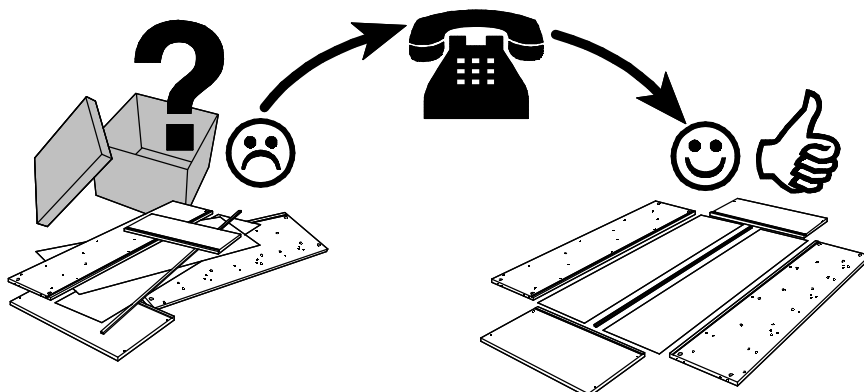
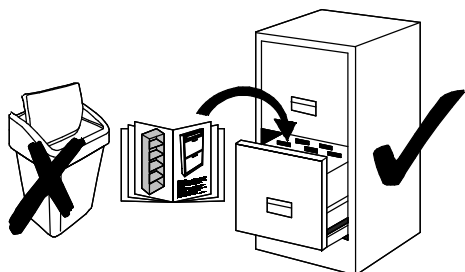

<b>A10</b> 22 x  Ø8 x 35	<b>B06</b> 2 x  Ø6,3 x 12	<b>B52</b> 12 x  Ø7 x 50	<b>C02</b> 4 x  fk.9	<b>C20</b> 4 x  2 mm	<b>D06</b> 4 x  M4 x 20
<b>E17</b> 8 x  Ø3,5 x 15	<b>F04</b> 1 x  4 mm	<b>F08</b> 1 x  45 x 20 x 16	<b>G02</b> 20 x  Ø15 x 11	<b>G06</b> 20 x  L - 34	<b>I01</b> 50 x  Ø1,2 x 20
<b>K01</b> 1 x  20 x 20 x 16 / 6,5	<b>N01</b> 24 x  Ø5 / Ø5	<b>P23</b> 2 x  131 x 20			

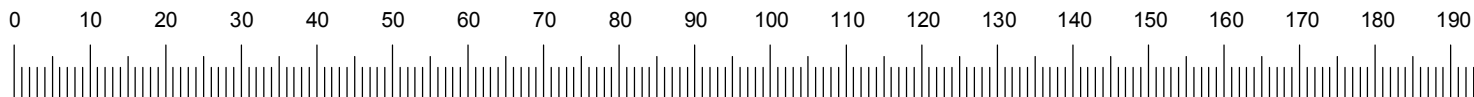
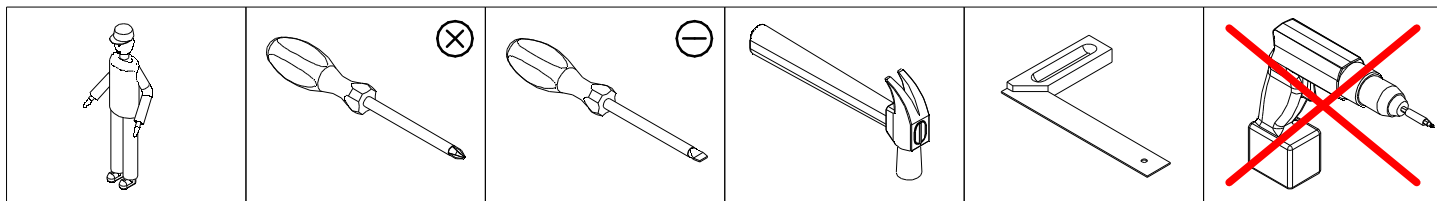

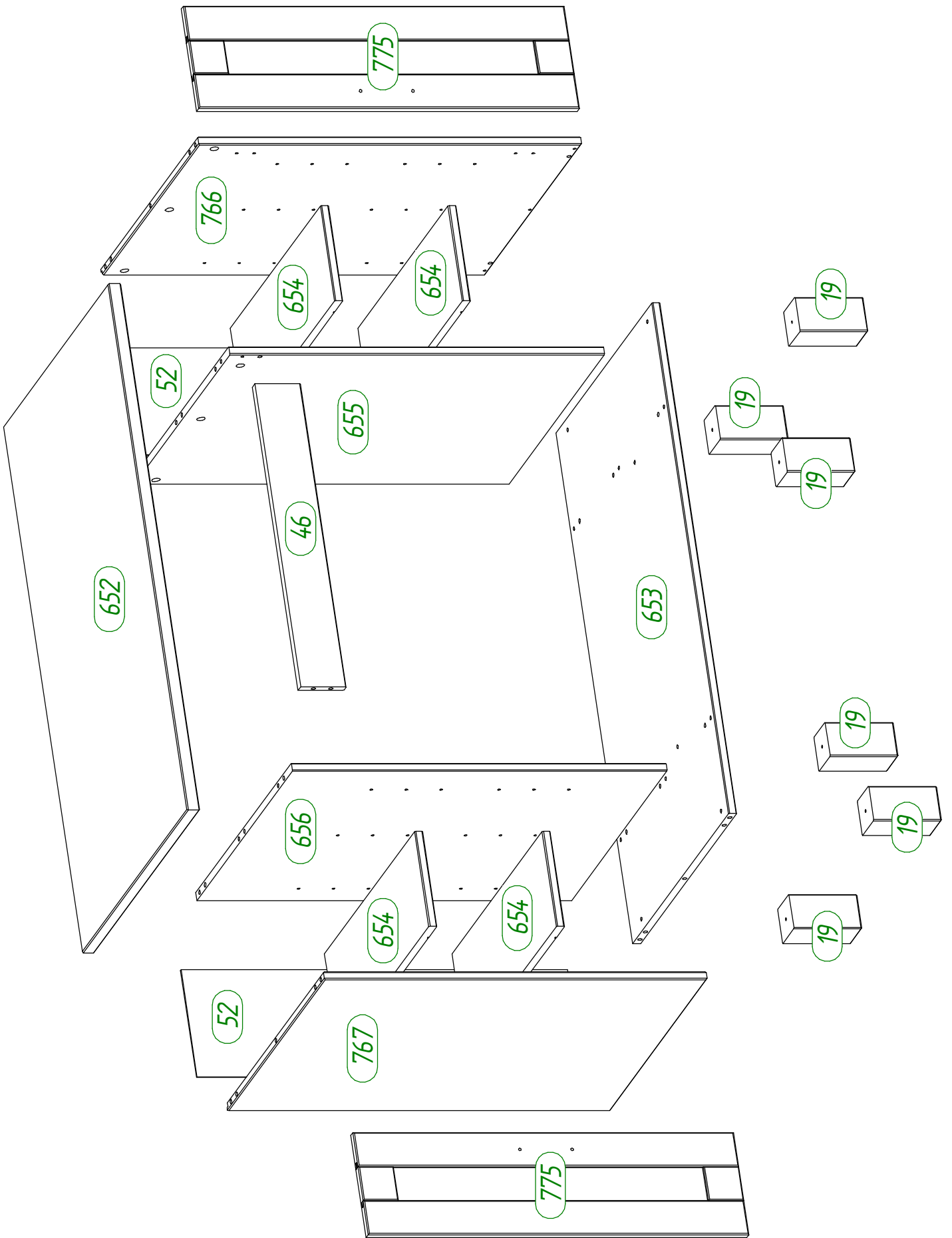

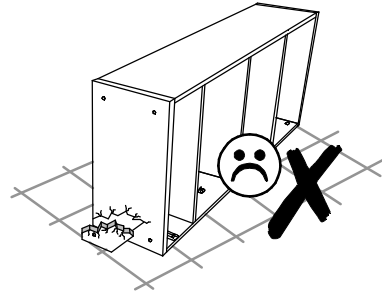
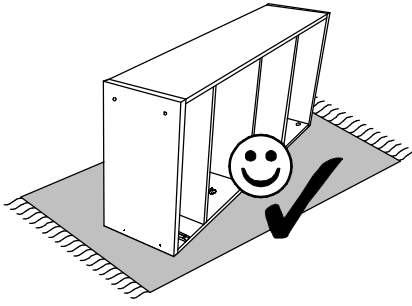

<b>A10</b>	16 x	<b>C20</b>	4 x	<b>G06</b>	8 x
Ø8 x 35		2 mm		L - 34	

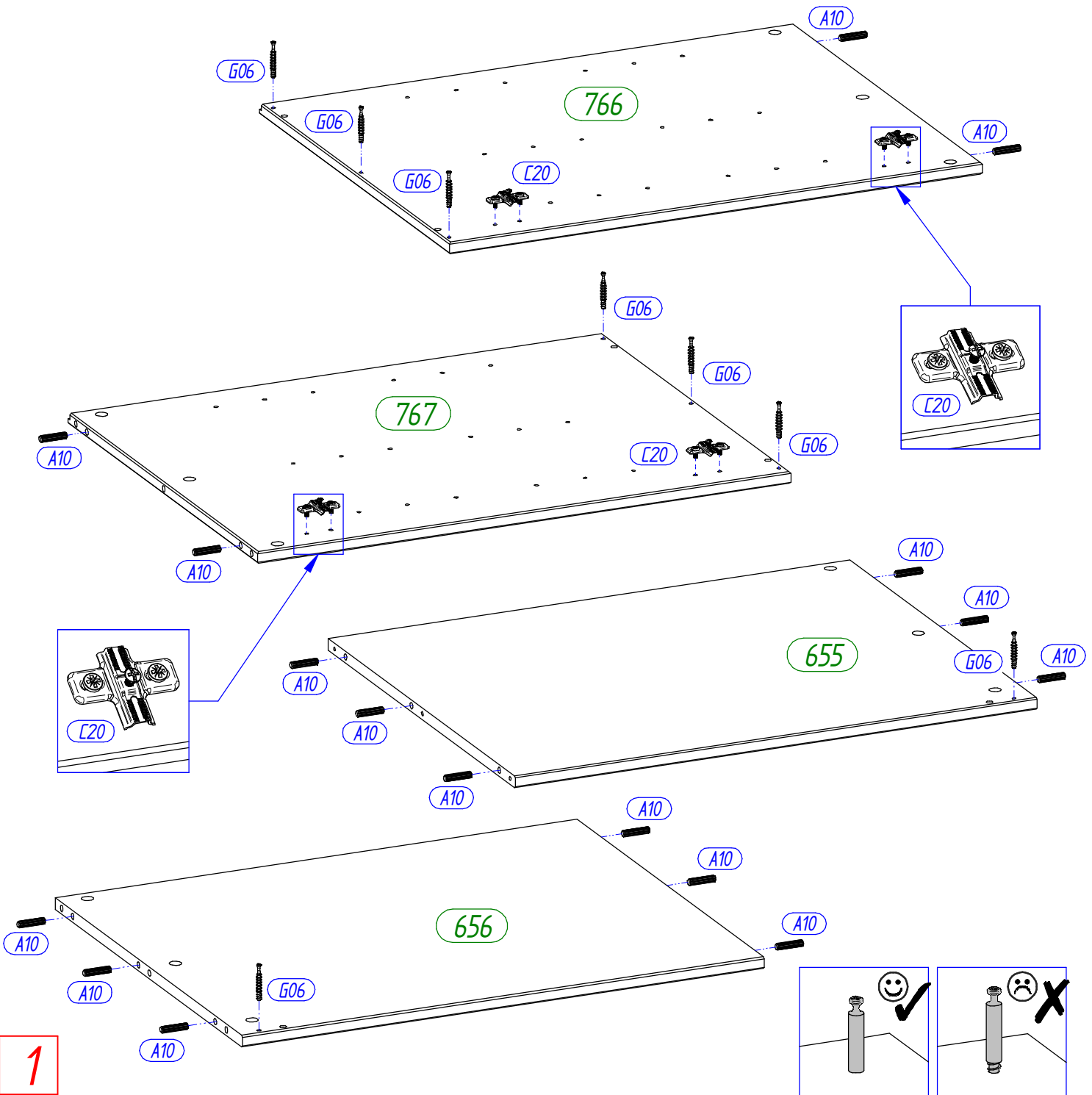

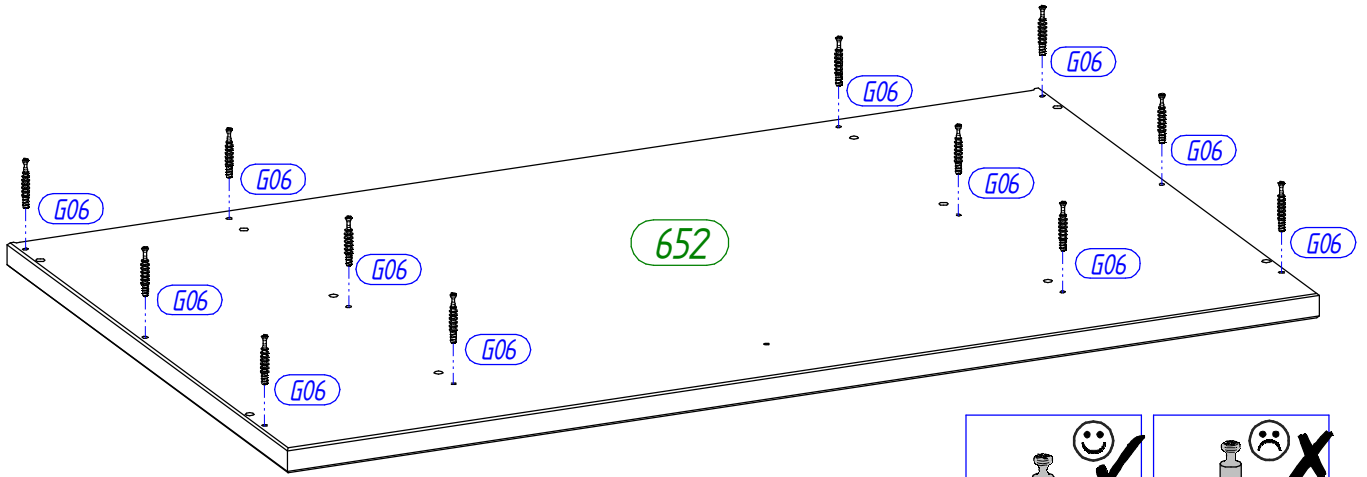
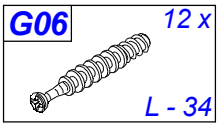

2

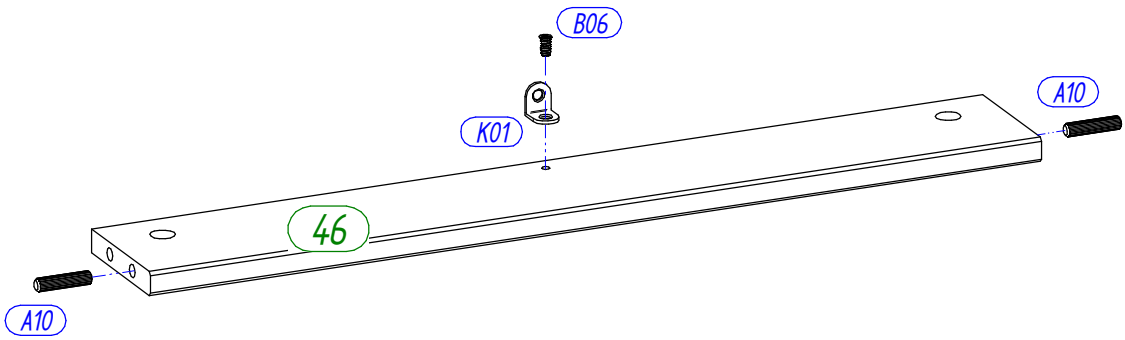
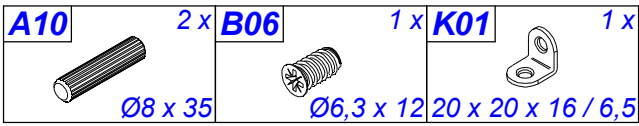
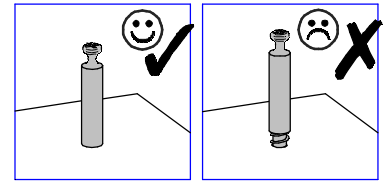

3

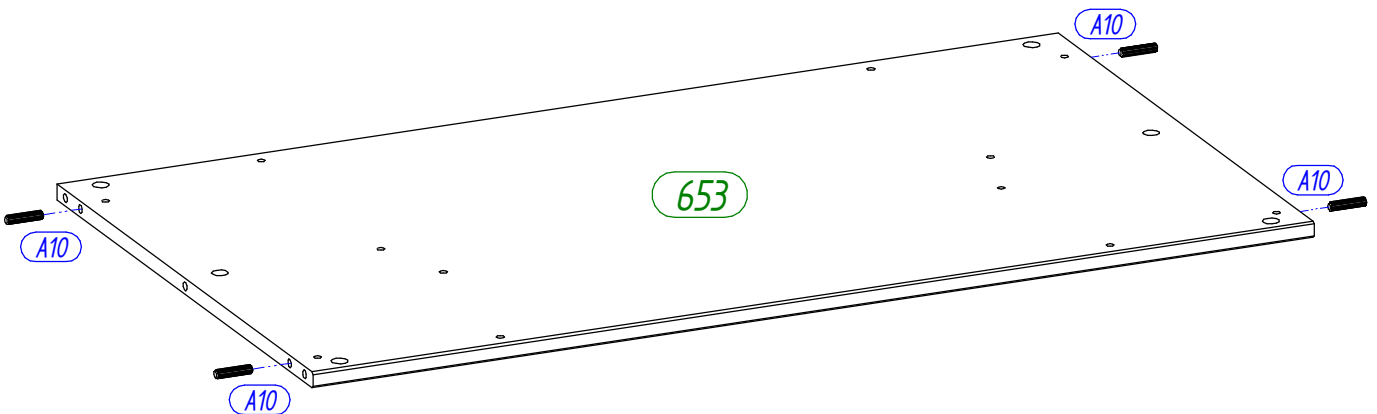
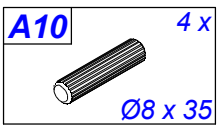

4

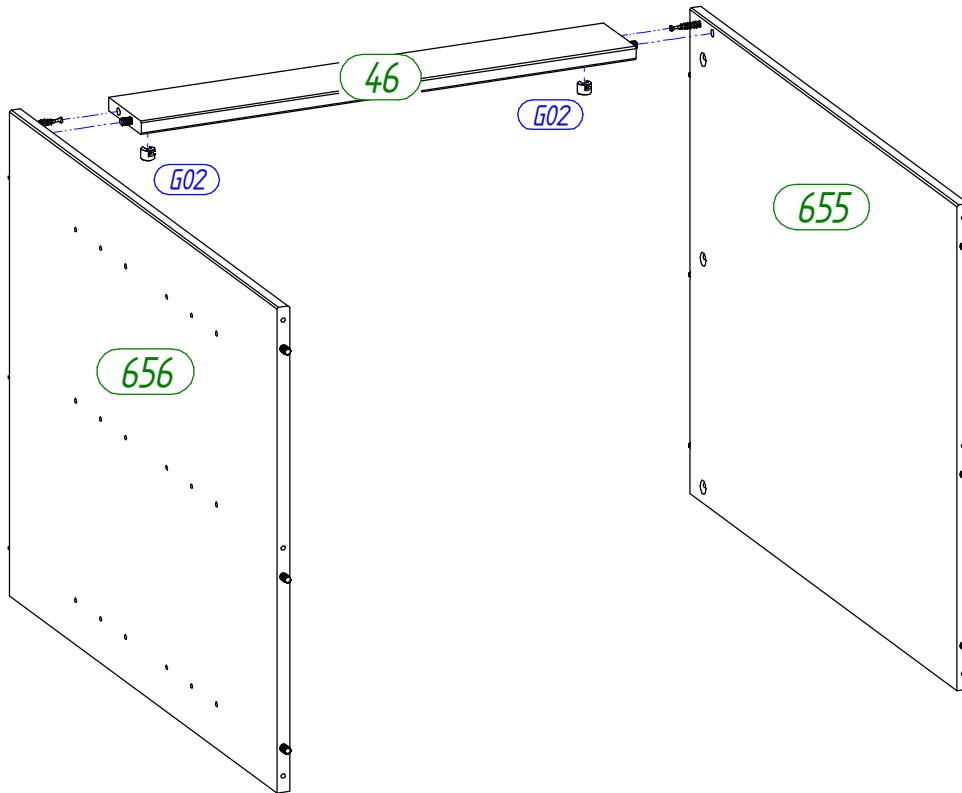
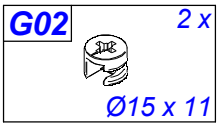

5

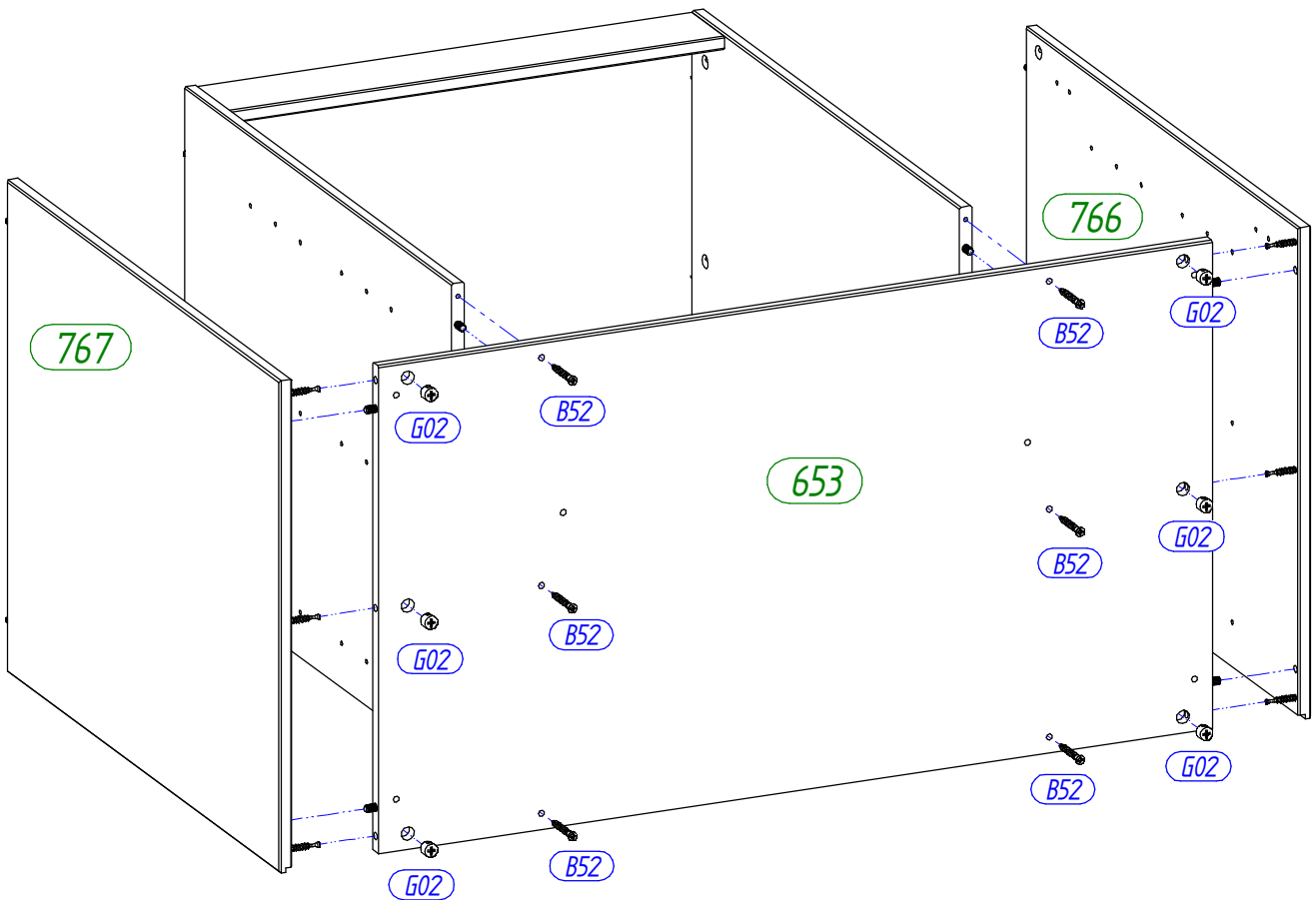
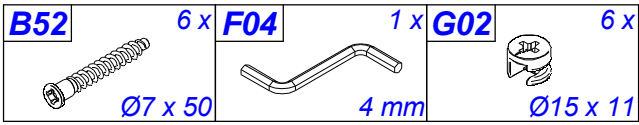

6



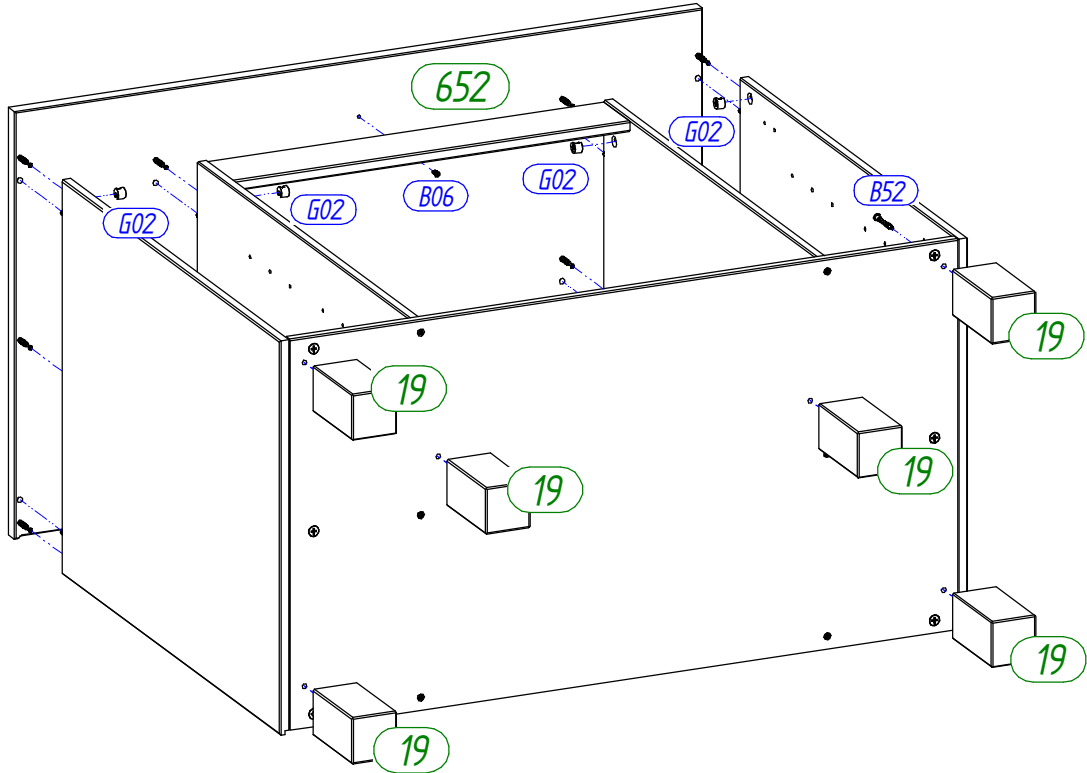
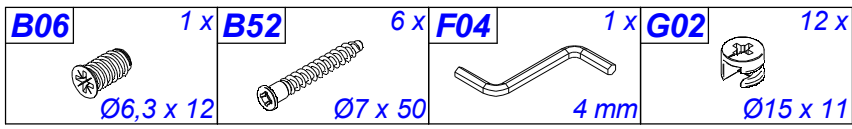



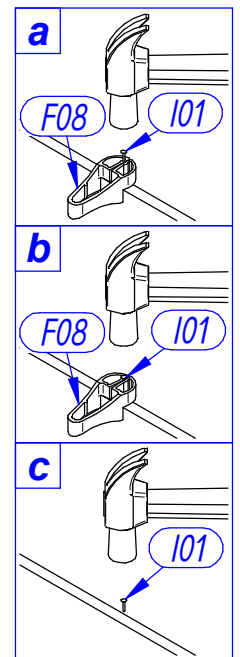
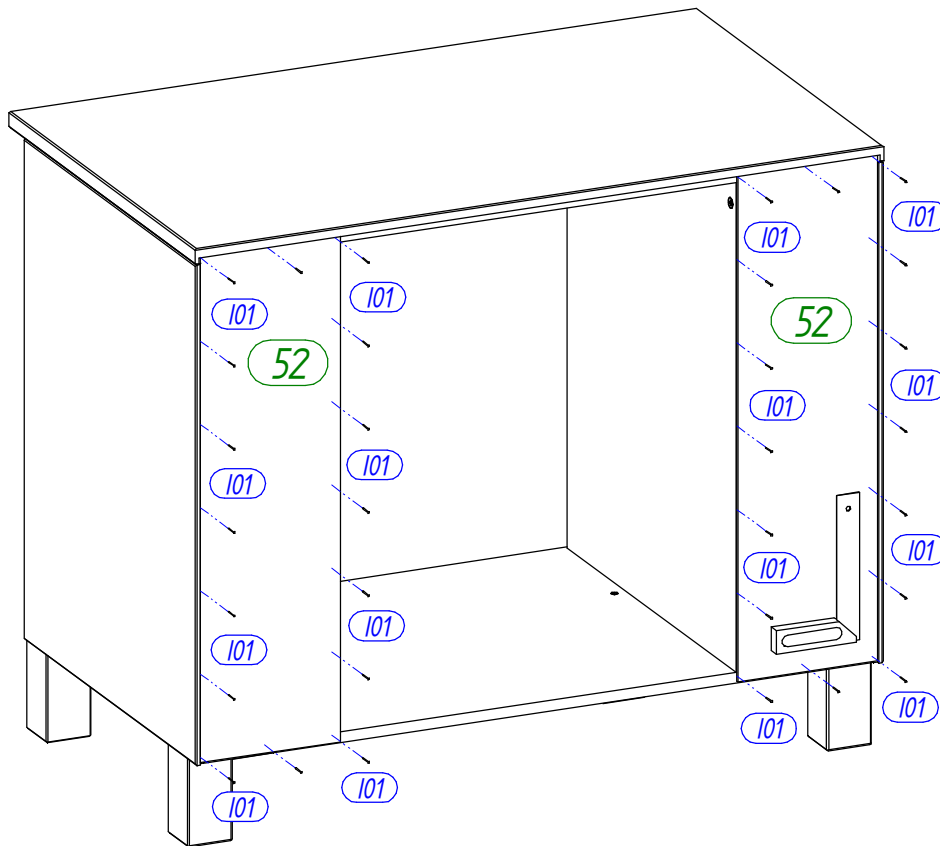
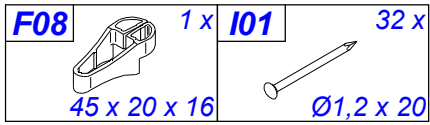

7

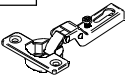

8

<b>C02</b>	4 x	<b>D06</b>	4 x	<b>E17</b>	8 x	<b>P23</b>	2 x
	fk.9		M4 x 20		Ø3,5 x 15		131 x 20

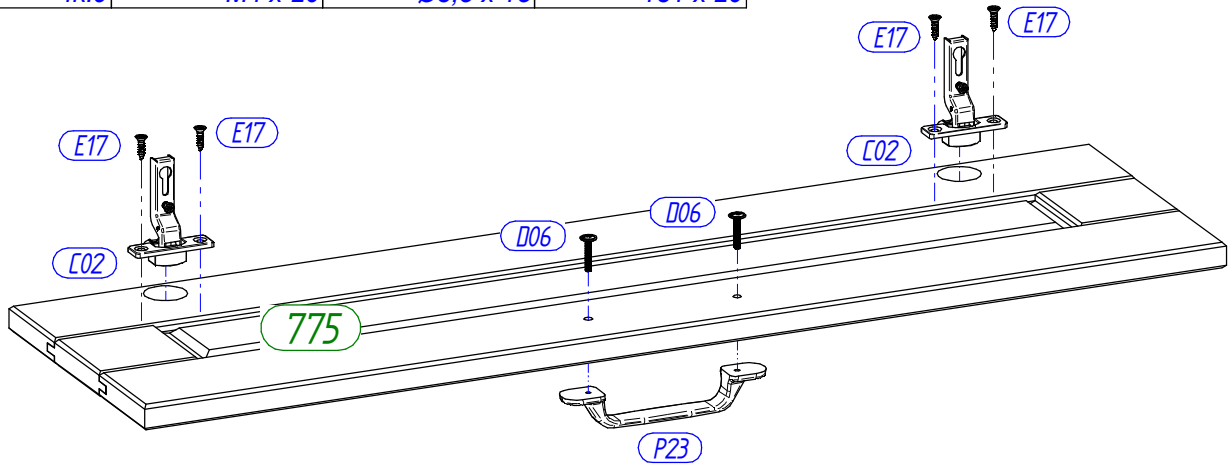

**9** x 2

<b>N01</b>	24 x
	Ø5 / Ø5

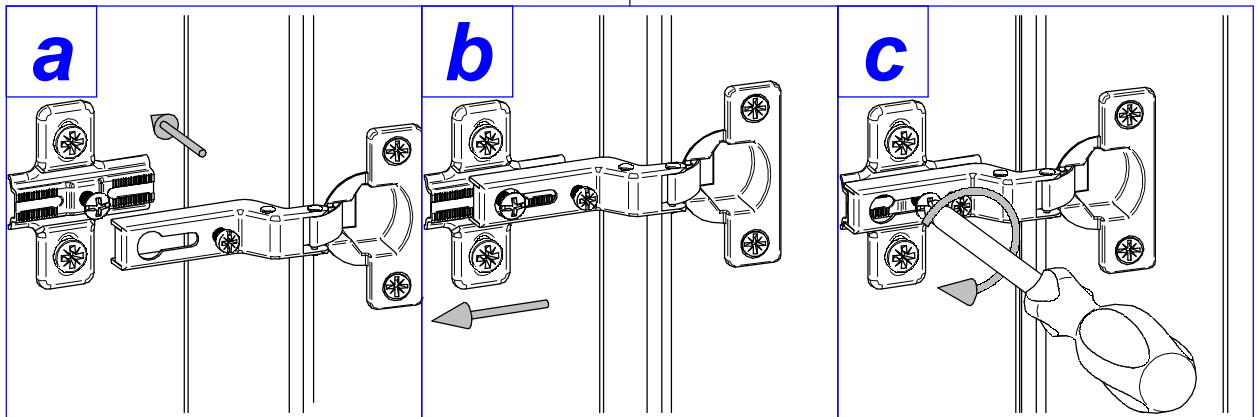
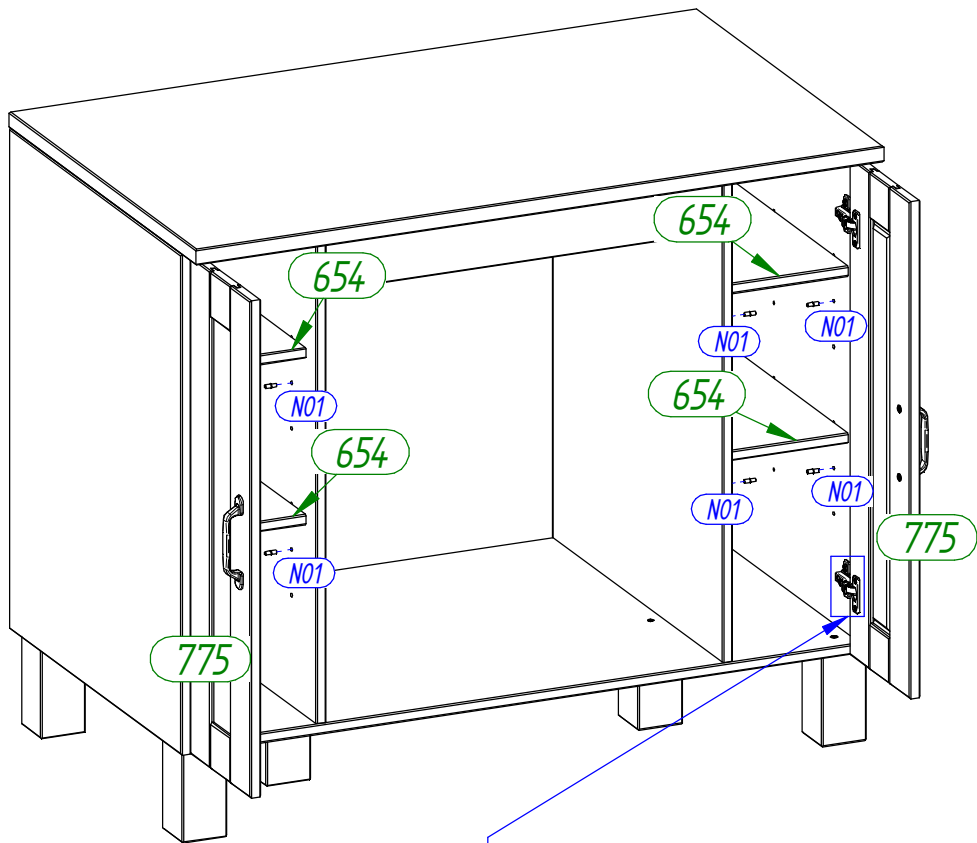

**10**

<b>(D)</b>	<i>Türen einstellen (Scharniere justieren)</i>
<b>(GB)</b>	<i>Adjusting the doors (adjusting the hinges)</i>
<b>(NL)</b>	<i>Deuren instellen (scharnieren afstellen)</i>
<b>(PL)</b>	<i>Nastawić drzwi (wyrównać zawiasy)</i>
<b>(TR)</b>	<i>Kapıların ayarlanması (menteşelerin seviye ayarı)</i>
<b>(RU)</b>	<i>Регулировка дверей (регулировка шарнира)</i>
<b>(FR)</b>	<i>Régler les portes (ajuster les charnières)</i>
<b>(IT)</b>	<i>Sistemare le porte (regolare le cerniere)</i>
<b>(CZ)</b>	<i>Vyrovnejte dvířka (seřďte závěsy)</i>
<b>(SK)</b>	<i>Nastavenie dverí (nastavenie závesov)</i>
<b>(HU)</b>	<i>Állítsa be az ajtókat (állítsa be a zsanérokat)</i>
<b>(RO)</b>	<i>Reglare uși (ajustare balamale)</i>

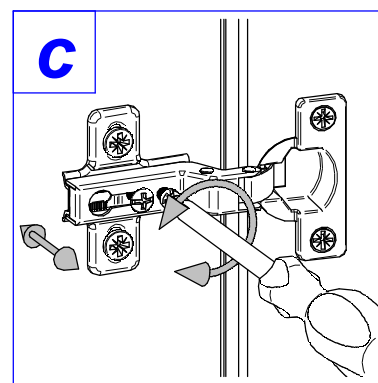
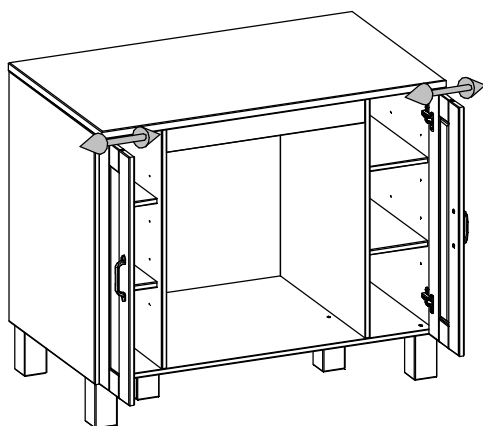
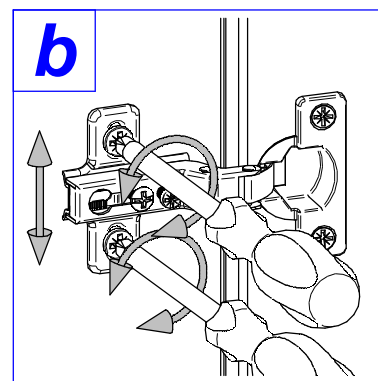
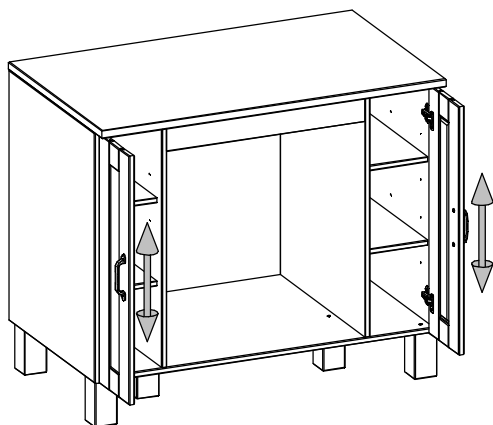
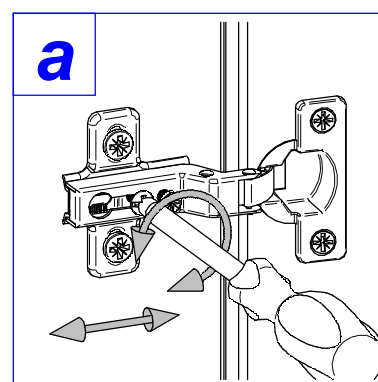
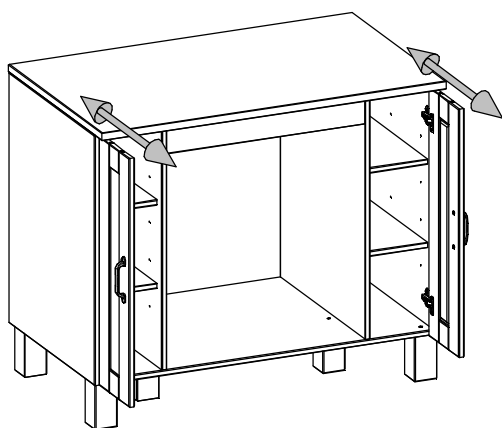

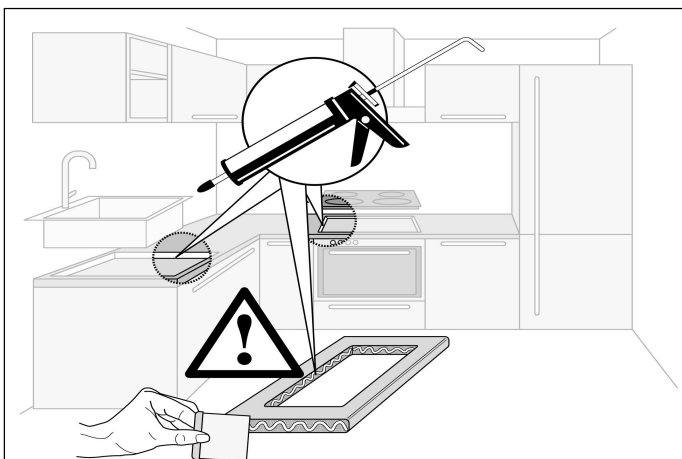
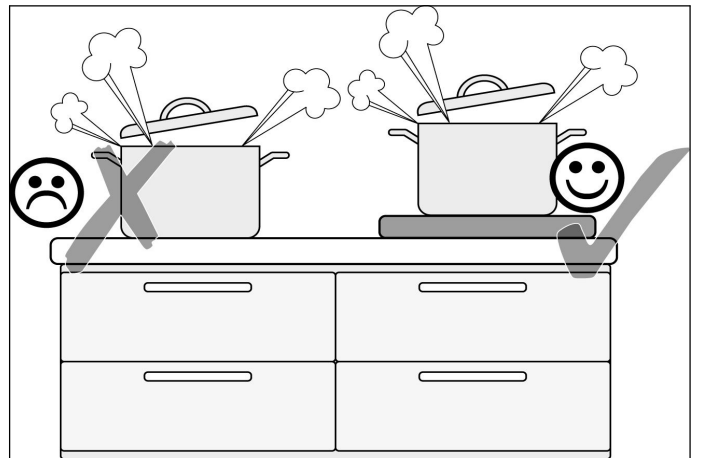
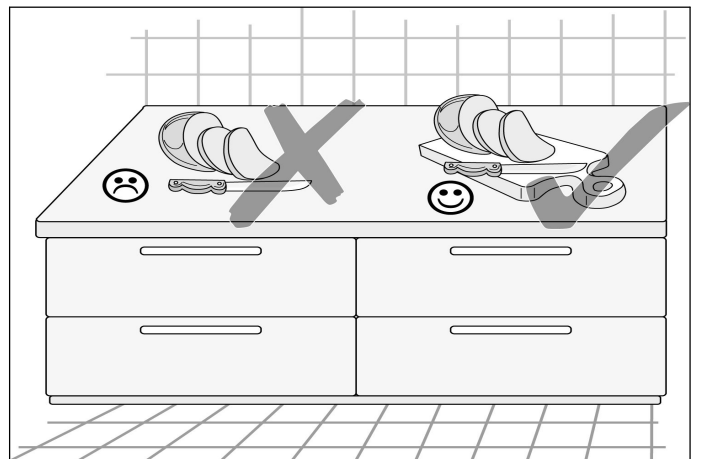
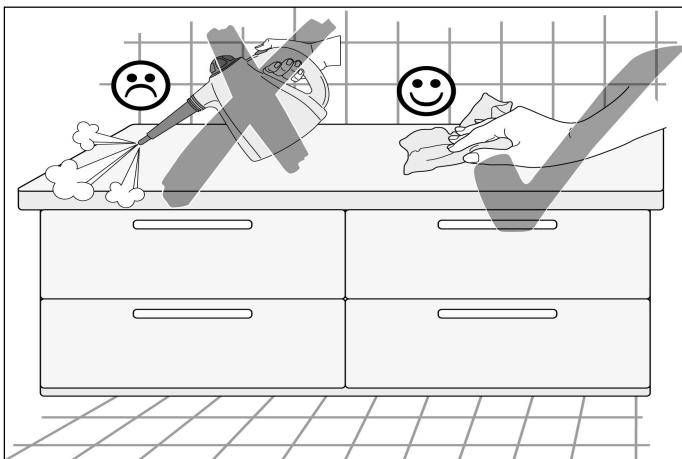
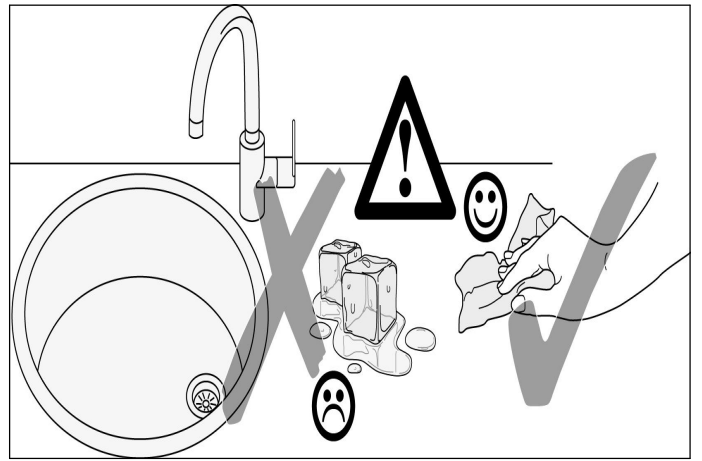
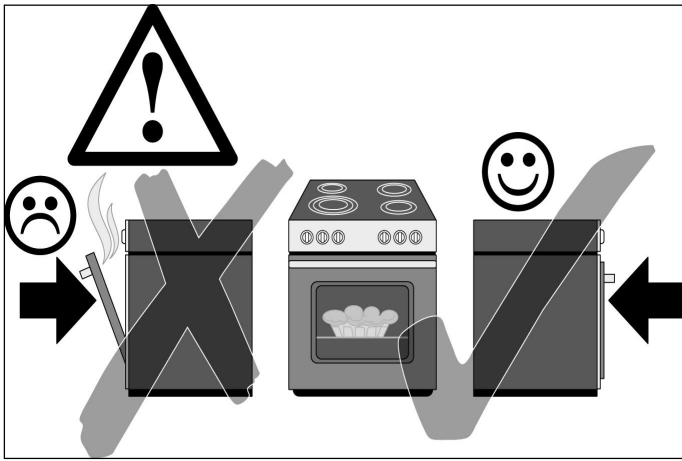

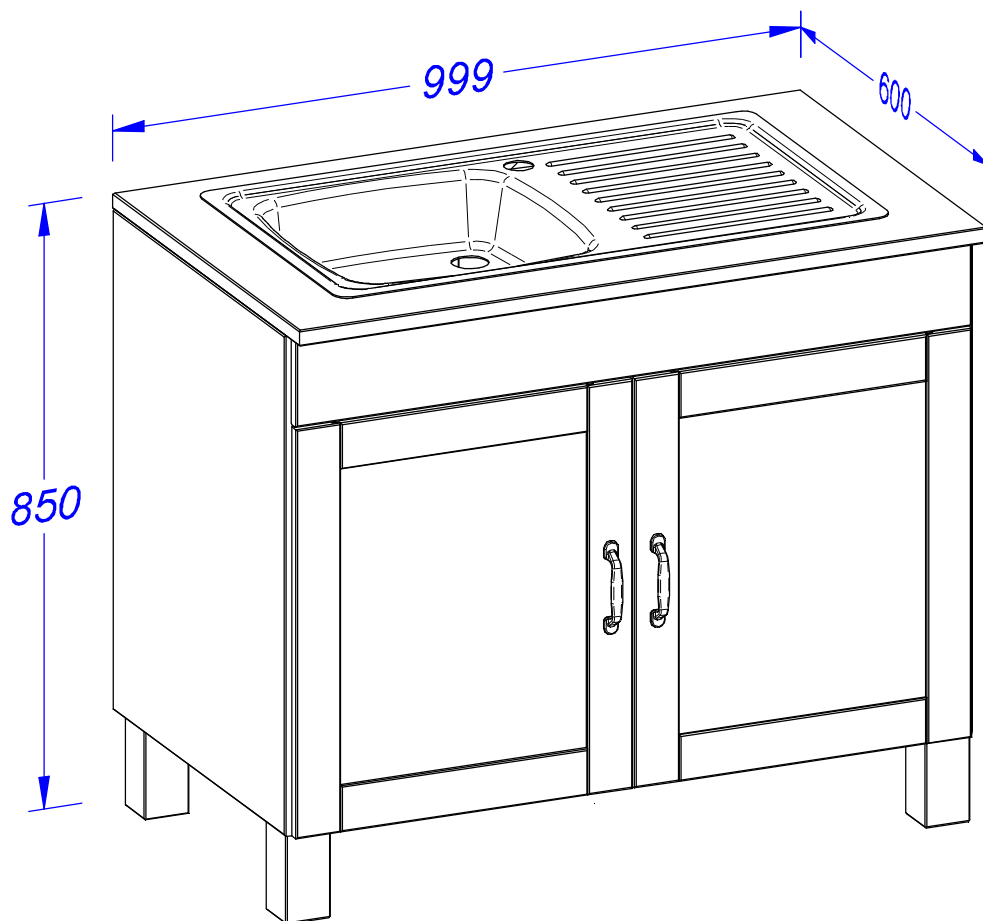

**(D)** *Montageanleitung*

**(NL)** *Handleiding voor de montage*

**(TR)** *Montaj talimatı*

**(FR)** *Notice de montage*

**(CZ)** *Montážní návod*

**(HU)** *Szerelési útmutató*

**(GB)** *Assembly instructions*

**(PL)** *Instrukcja montażu*

**(RU)** *Инструкция по монтажу*

**(IT)** *Istruzioni di montaggio*

**(SK)** *Návod na montáž*

**(RO)** *Instrucțiuni de montaj*

Name • Nom • Nome • Naam • Nazwa • Jméno •  
Názov • Név • Denumire • Isim • Название

Nr. • No. • N° • Номер • Č • Sz

Typ • Type • Tip • Tipus • Tipo • Тип

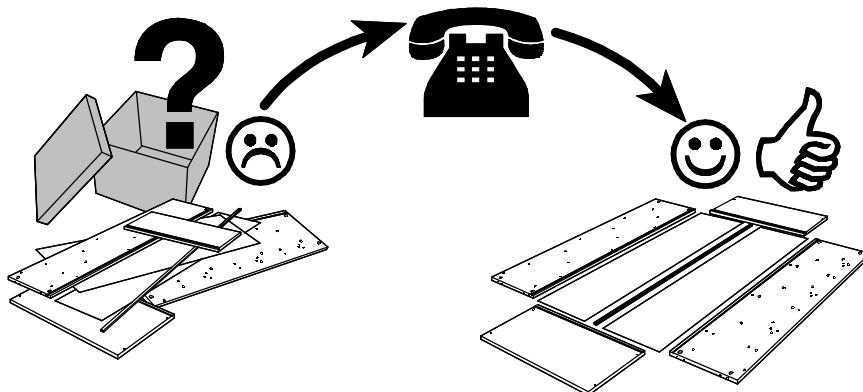
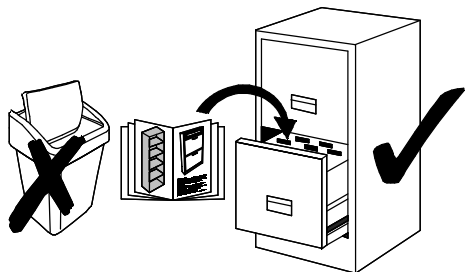

<b>A10</b> 8 x  Ø8 x 35	<b>B06</b> 8 x  Ø6,3 x 12	<b>B52</b> 4 x  Ø7 x 50	<b>C02</b> 4 x  fk.9	<b>C20</b> 4 x  2 mm	<b>D06</b> 4 x  M4 x 20
<b>E17</b> 10 x  Ø3,5 x 15	<b>F04</b> 1 x  4 mm	<b>F08</b> 1 x  45 x 20 x 16	<b>G02</b> 12 x  Ø15 x 11	<b>G06</b> 12 x  L - 34	<b>I01</b> 50 x  Ø1,2 x 20
<b>K01</b> 4 x  20 x 20 x 16 / 6,5	<b>P23</b> 2 x  131 x 20	<b>R19</b> 1 x  35 x 40			

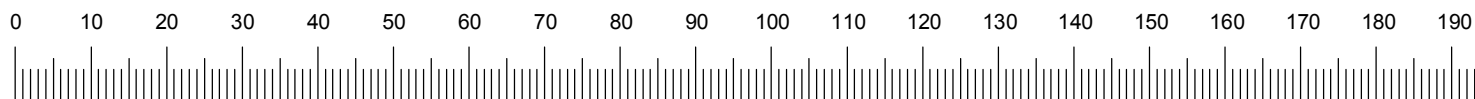
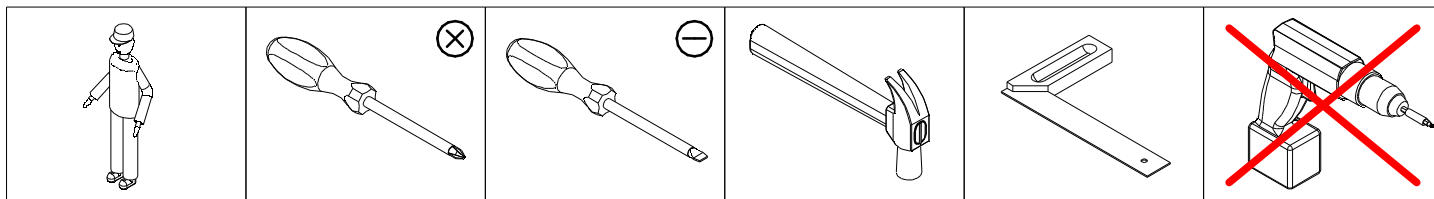

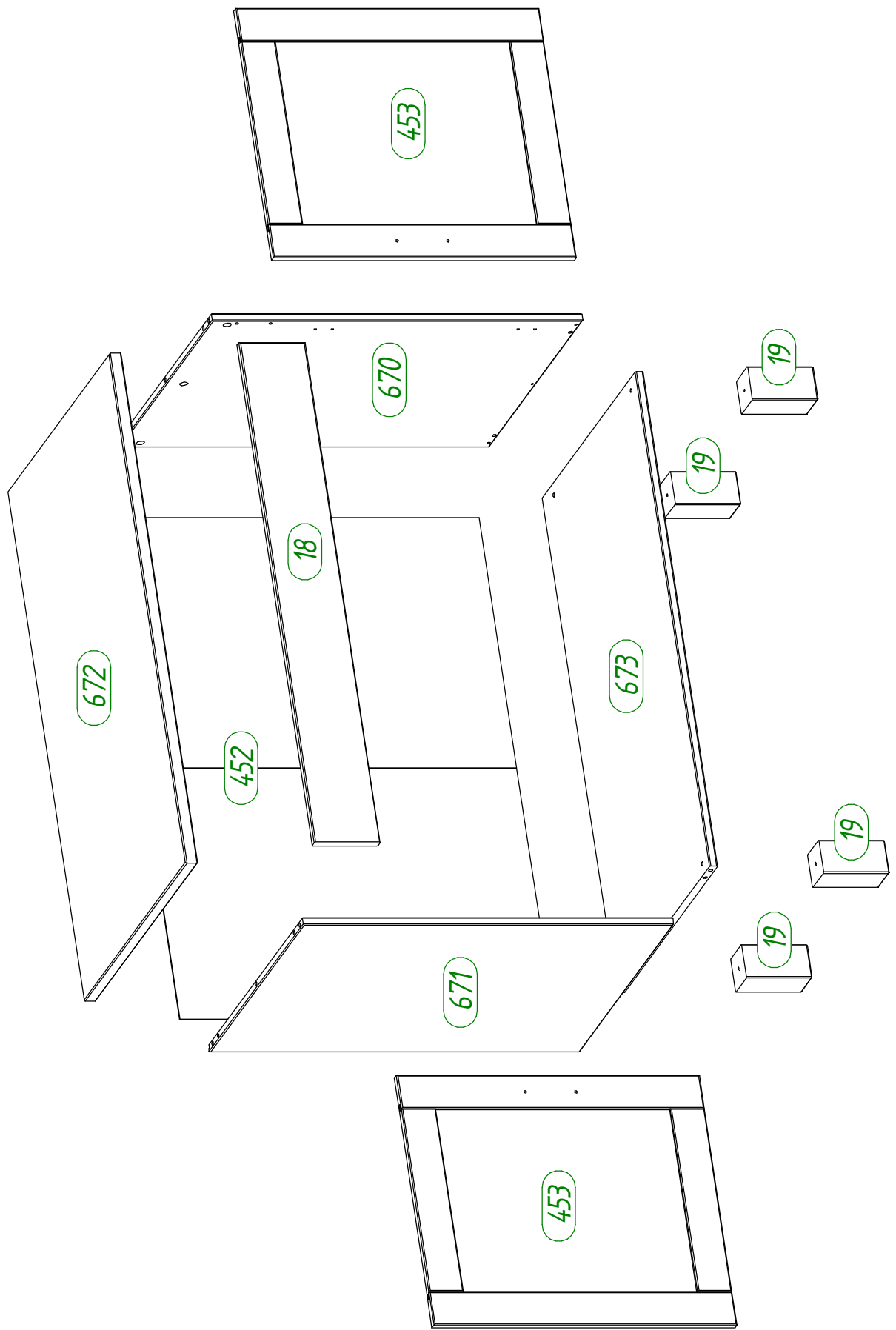

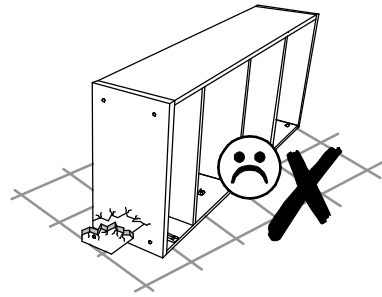
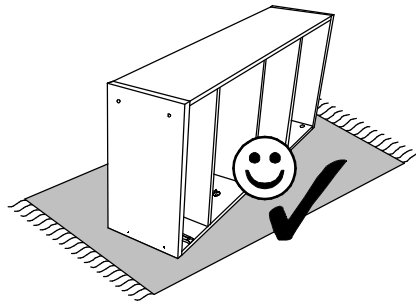

<b>A10</b>	4 x	<b>B06</b>	4 x	<b>C20</b>	4 x	<b>G06</b>	6 x	<b>K01</b>	4 x
Ø8 x 35		Ø6,3 x 12		2 mm		L - 34		20 x 20 x 16 / 6,5	

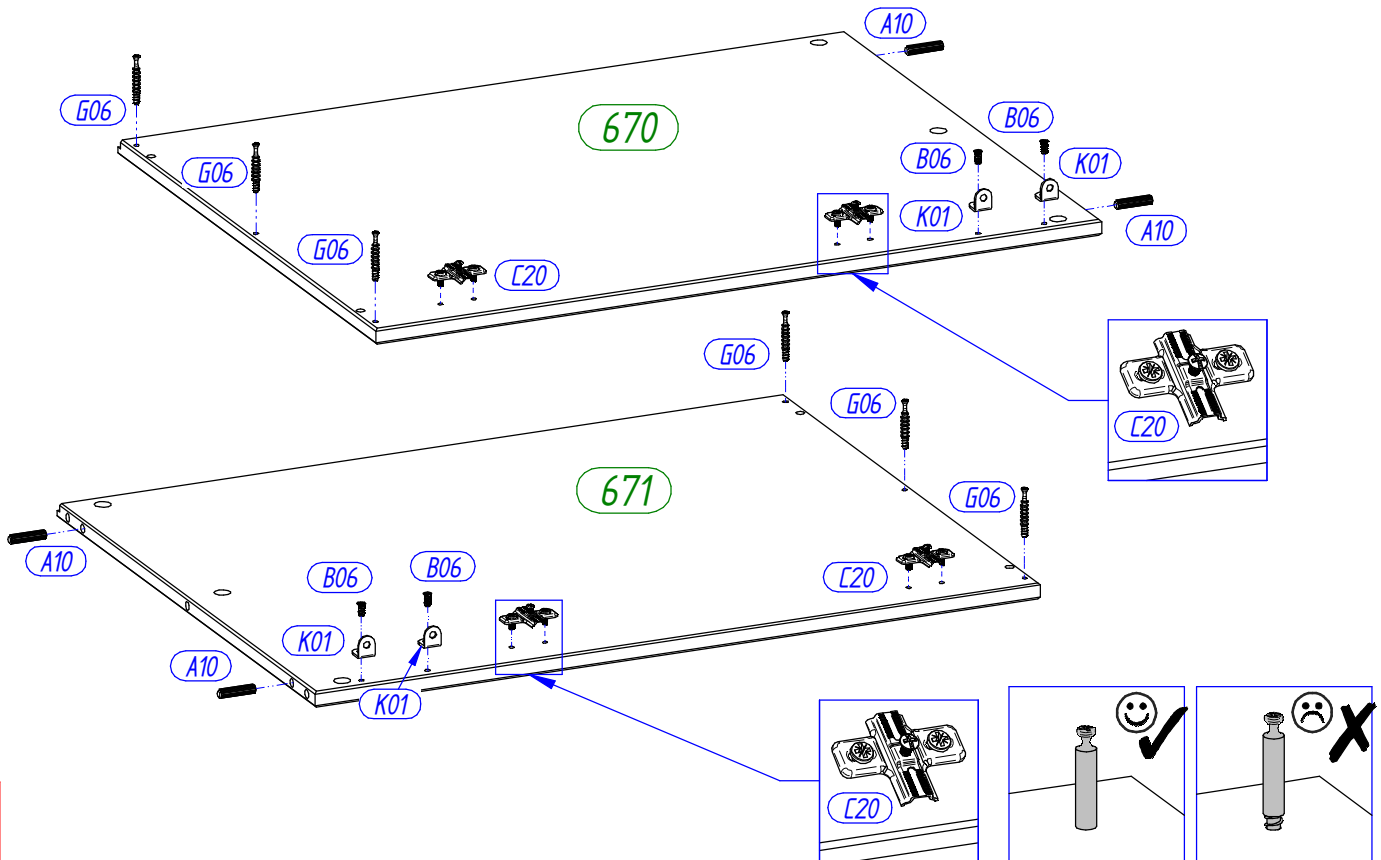

1

<b>A10</b>	4 x	<b>E17</b>	2 x	<b>R19</b>	1 x
Ø8 x 35		Ø3,5 x 15		35 x 40	

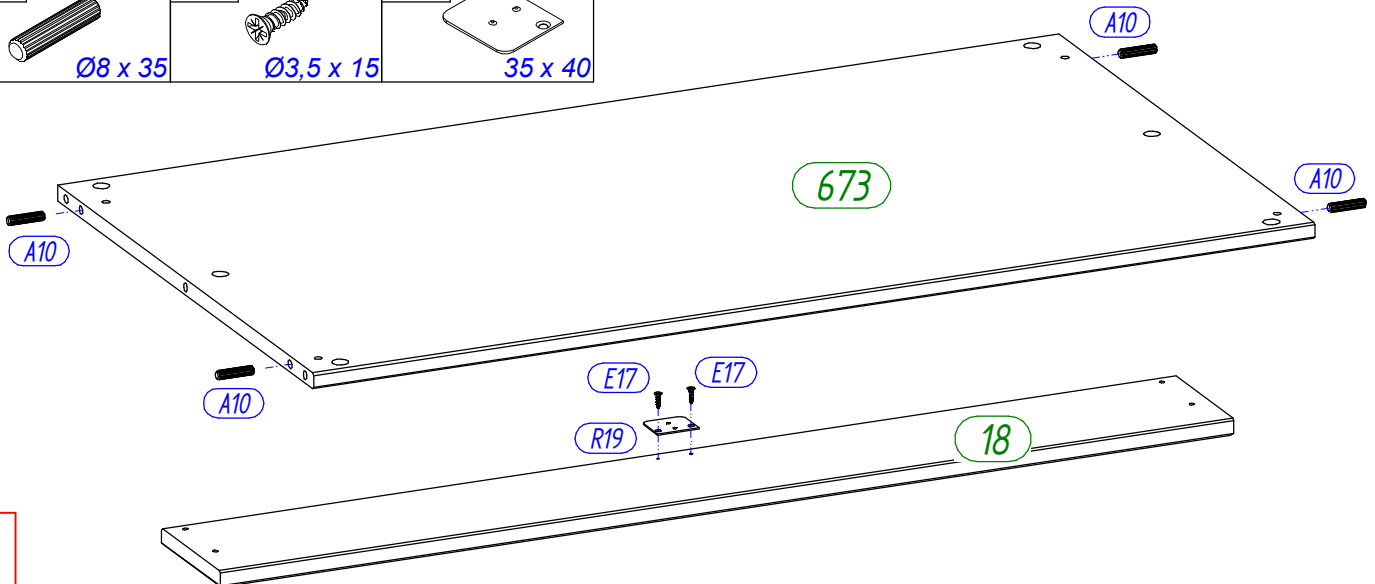

2



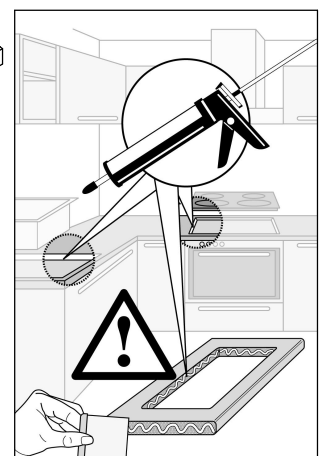
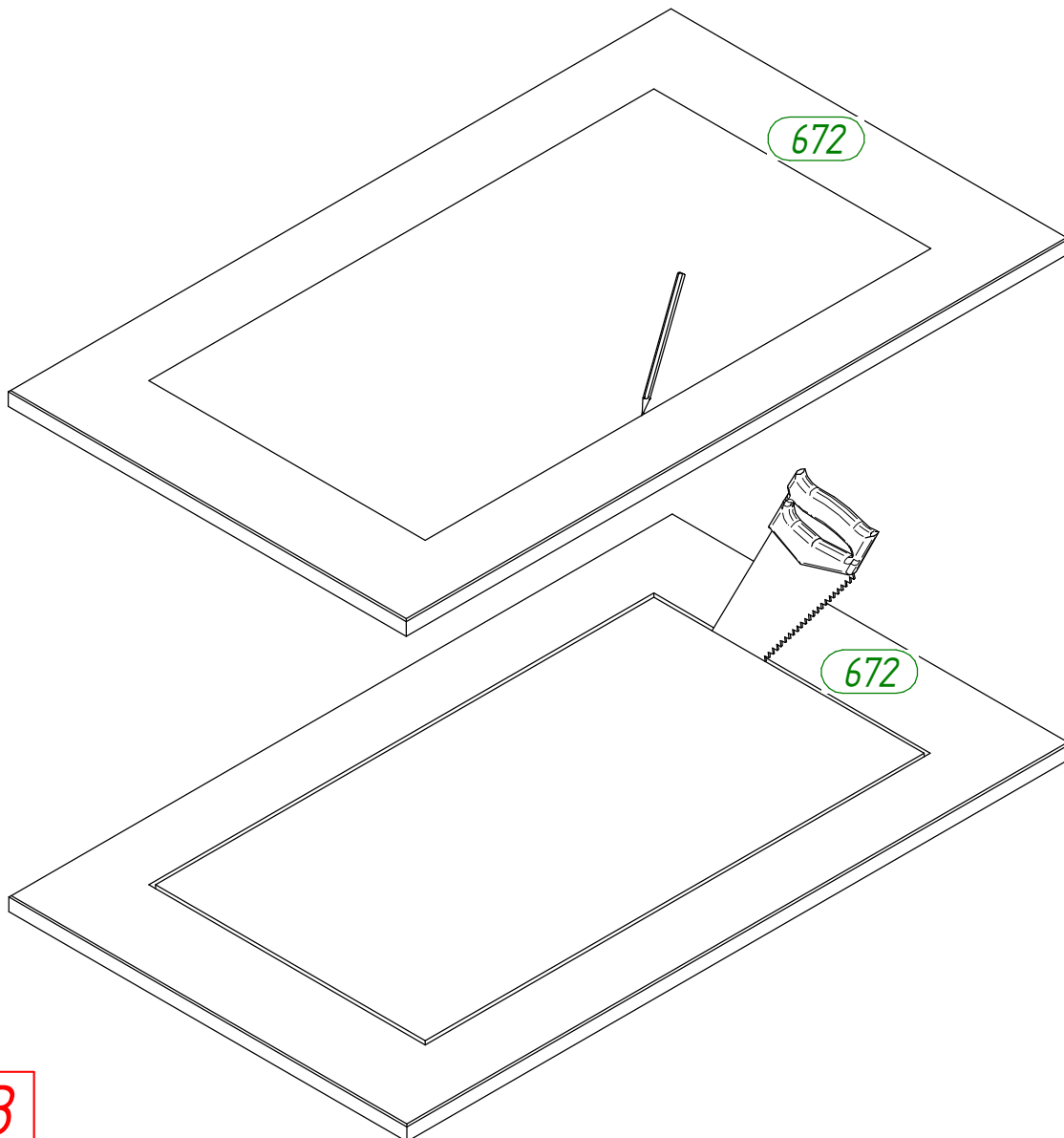
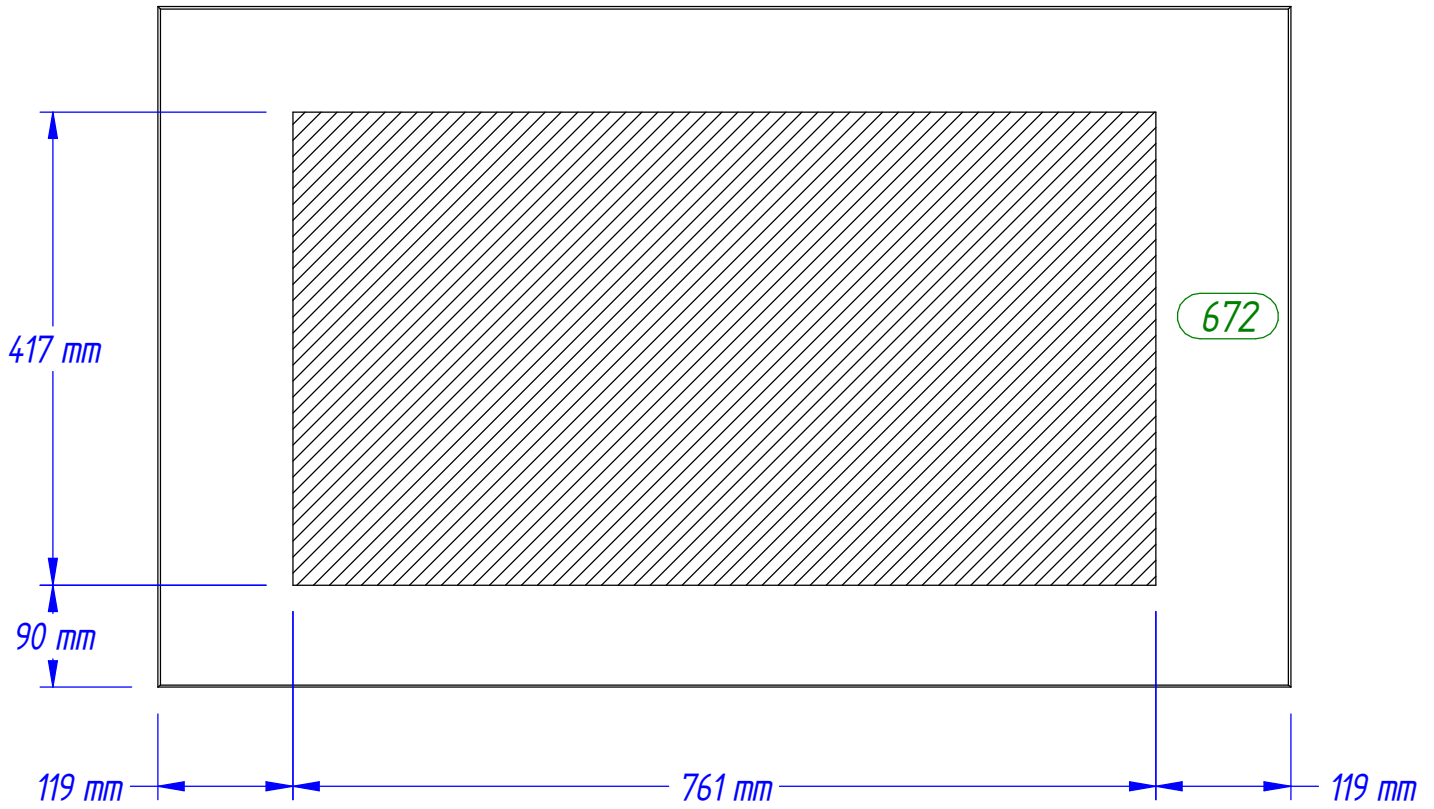

3

**Achtung • Attention • Attenzione • Opgelet • Uwaga • Pozor • Figyelem • Atenție • Dikkat • Внимание**

<b>(D)</b>	Bitte montieren Sie das Spülbecken auf der Topplatte laut Aufbauanleitung des Spülbeckens als erstes.
<b>(GB)</b>	Please mount the basin onto the top plate first, as described in the manual.
<b>(NL)</b>	Plaats de bak eerst op de bovenste plaat zoals beschreven in de handleiding.
<b>(PL)</b>	W pierwszej kolejności zamontować zlewozmywak na górnym blacie zgodnie z instrukcją montażu zlewozmywaka.
<b>(TR)</b>	İlk önce, kullanım kılavuzunda tanımlandığı üzere evyenin en üst tabaka üzerinde kurulumunu gerçekleştirin.
<b>(RU)</b>	Сначала установите резервуар на верхнюю плиту как описано в руководстве.
<b>(FR)</b>	S'il vous plaît installer le bassin sur la plaque du haut d'abord, comme décrit dans le manuel.
<b>(IT)</b>	Si prega di montare il bacino sulla piastra superiore, come descritto nel manuale.
<b>(CZ)</b>	Prosím, držák pánve na horní desce první, jak je popsáno v manuálu.
<b>(SK)</b>	Prosím, držiak panvice na hornej doske prvé, ako je popísané v manuáli.
<b>(HU)</b>	Kérjük, szerelje fel a medencét rá a felső lemez első, ahogy az a kézikönyvben.
<b>(RO)</b>	Vă rugăm să mount bazinul pe placa de top în primul rând, așa cum este descris în manual.

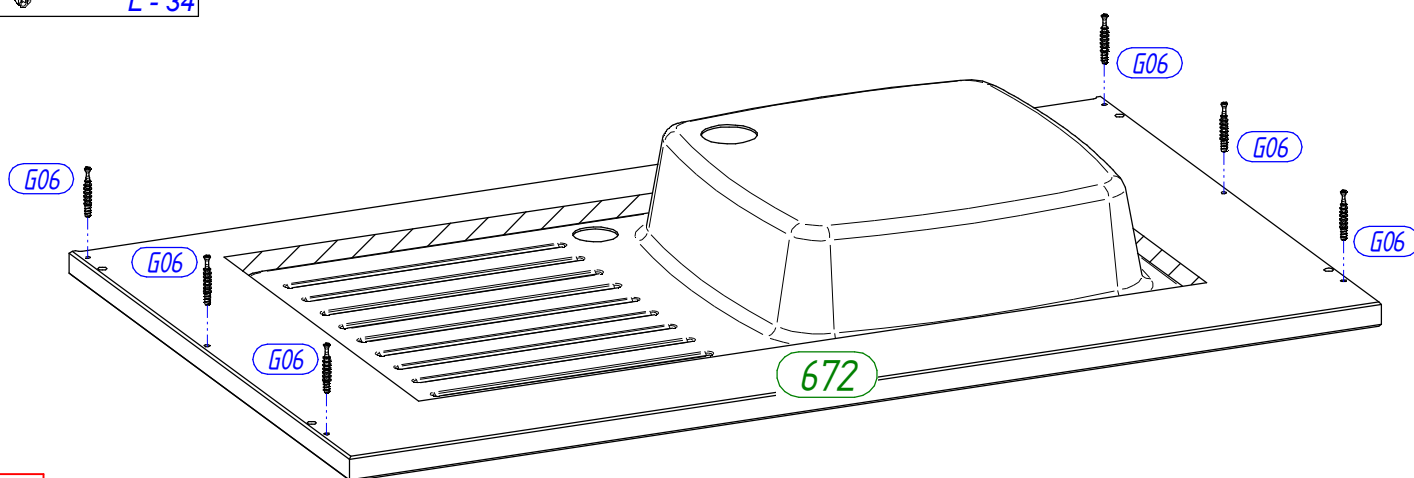
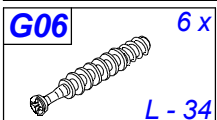

**4**

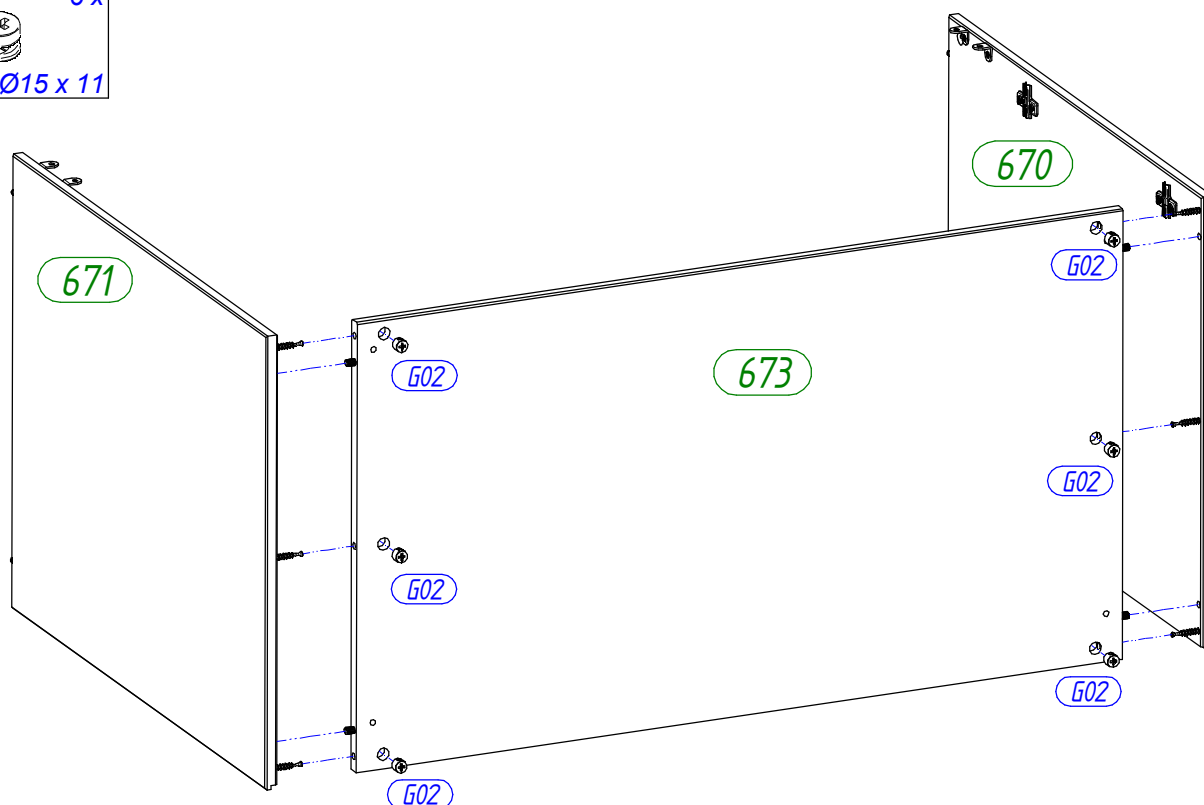
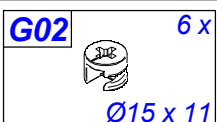

**5**

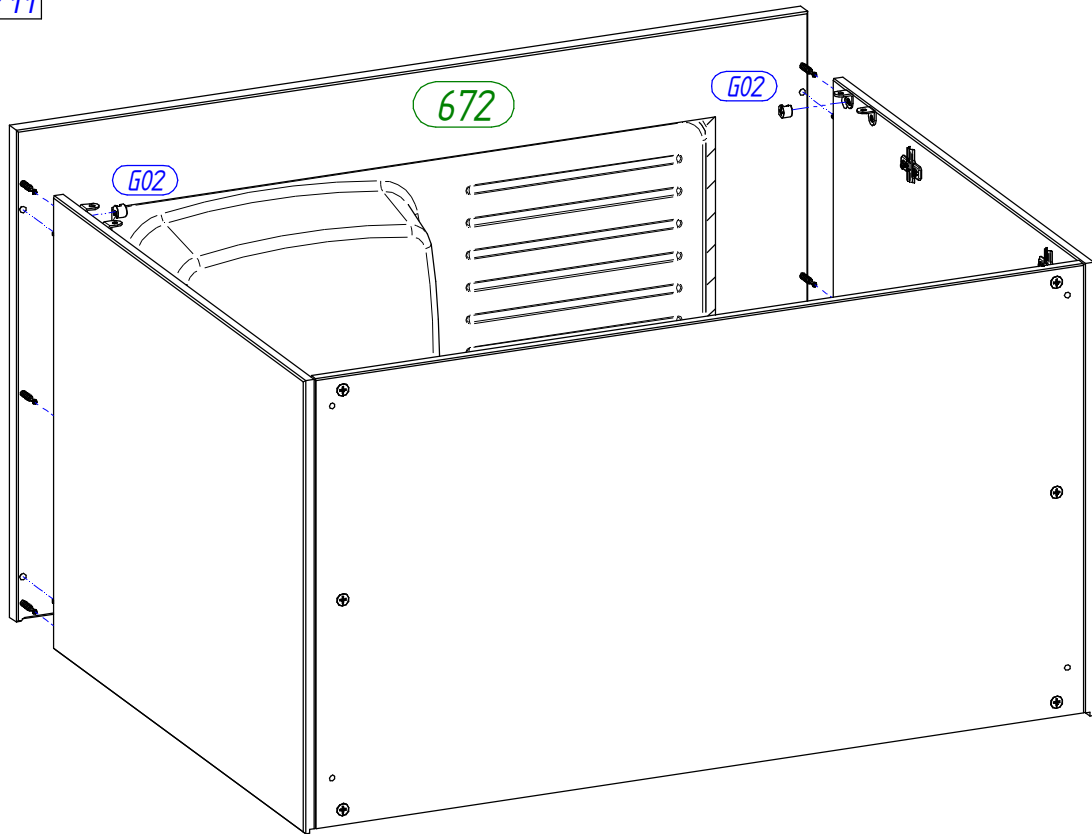
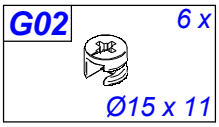

6

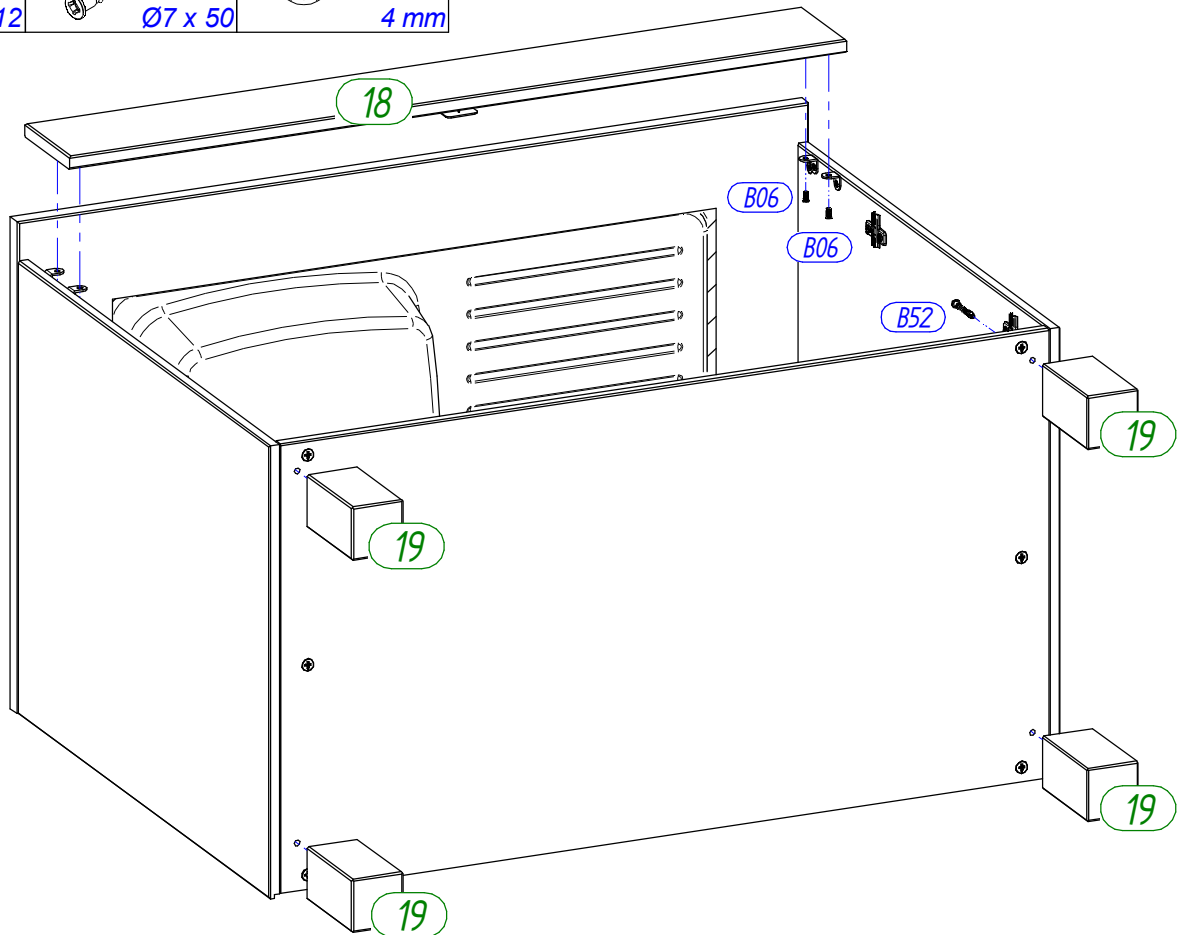
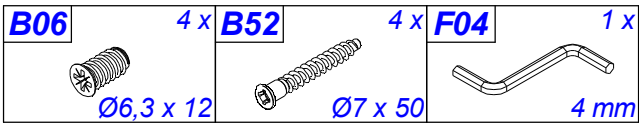

7

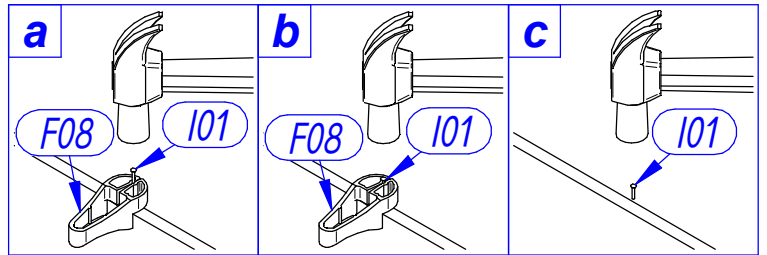
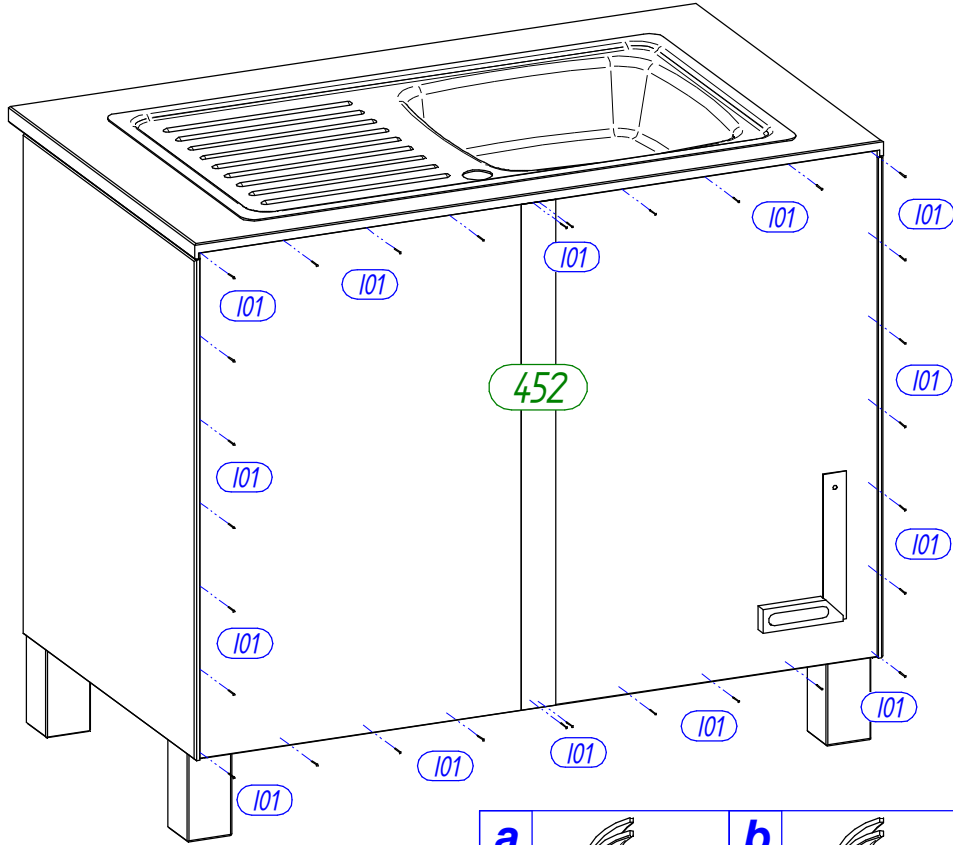
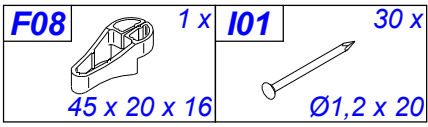

**8**

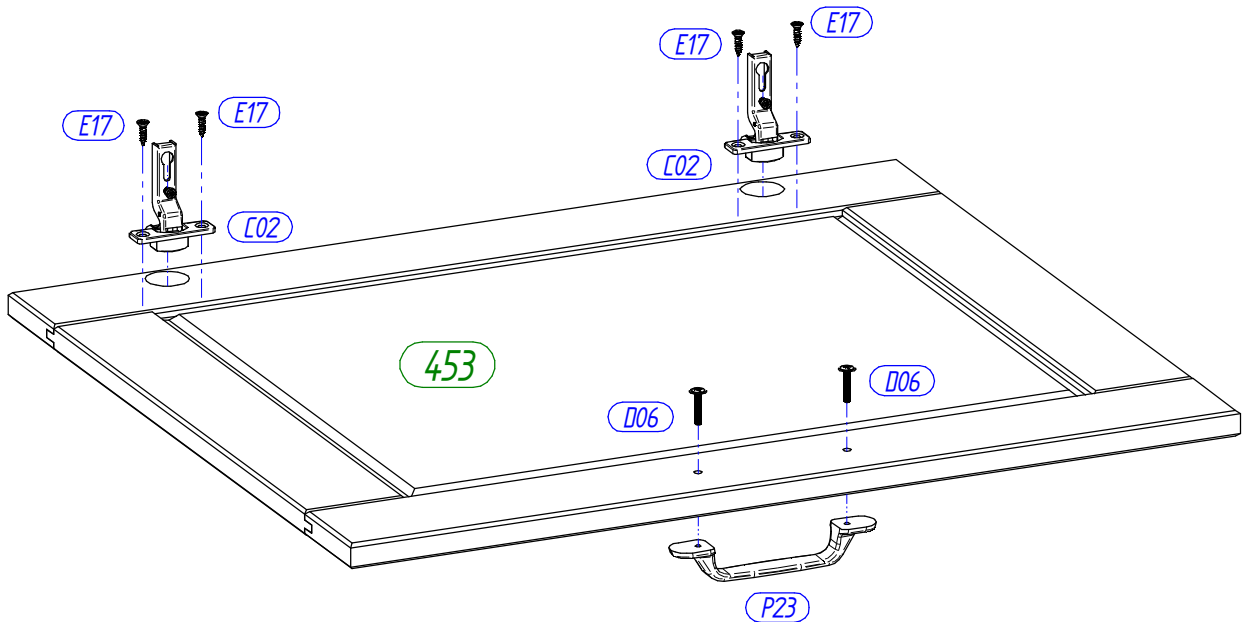
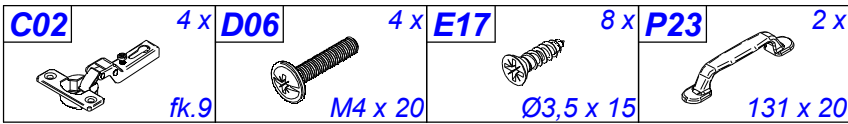

**9** x 2

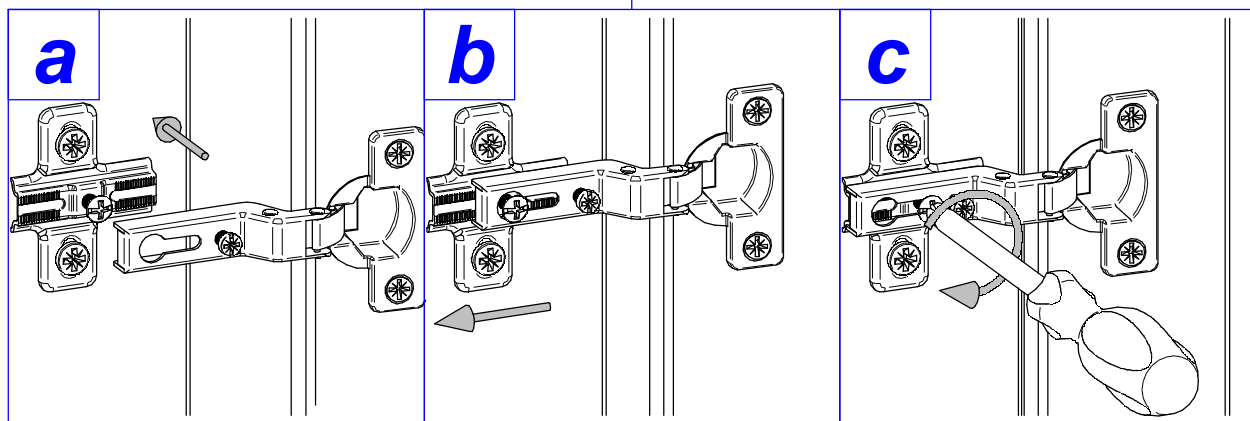
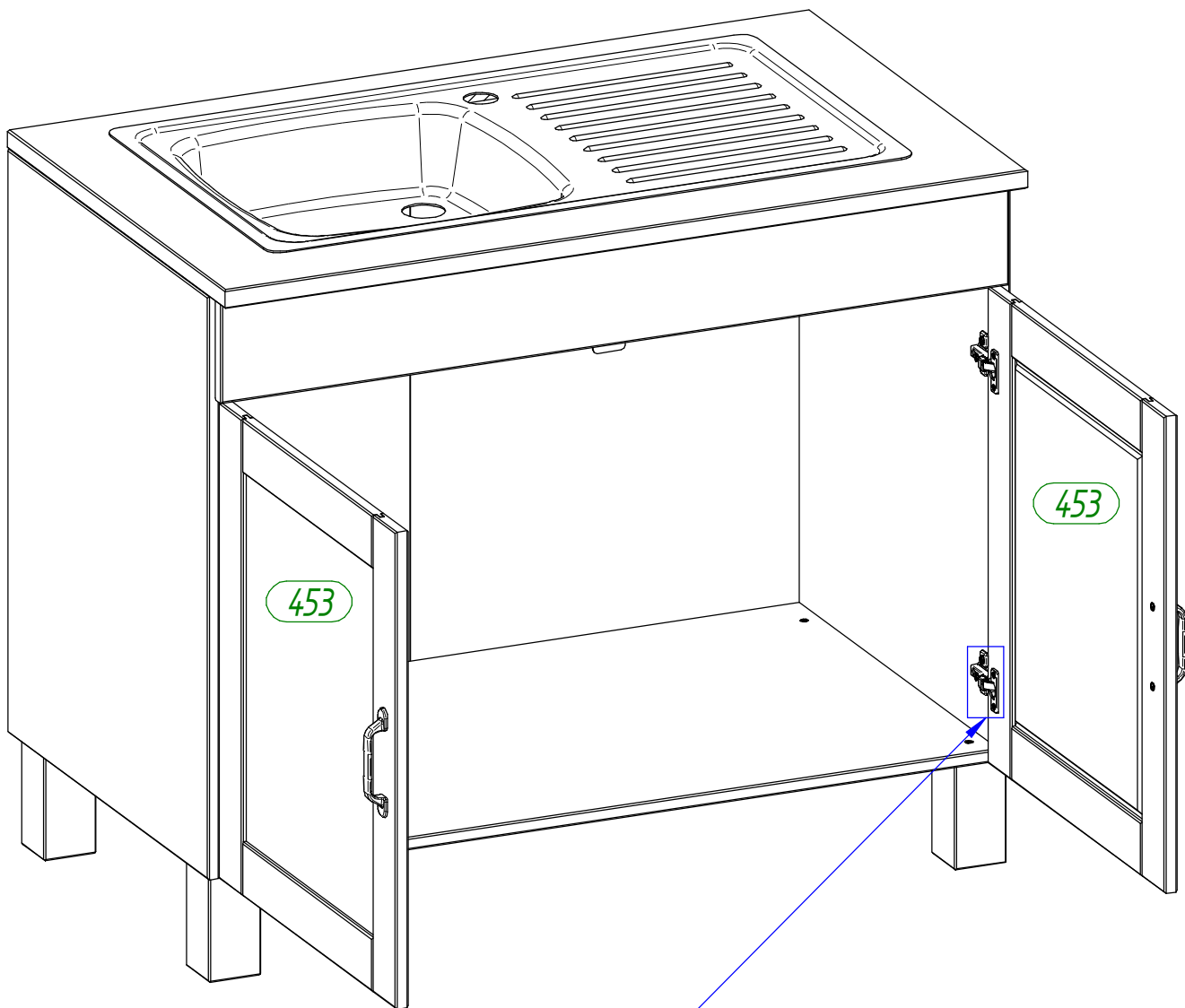

<b>(D)</b>	<i>Türen einstellen (Scharniere justieren)</i>
<b>(GB)</b>	<i>Adjusting the doors (adjusting the hinges)</i>
<b>(NL)</b>	<i>Deuren instellen (scharnieren afstellen)</i>
<b>(PL)</b>	<i>Nastawić drzwi (wyrównać zawiasy)</i>
<b>(TR)</b>	<i>Kapıların ayarlanması (menteşelerin seviye ayarı)</i>
<b>(RU)</b>	<i>Регулировка дверей (регулировка шарнира)</i>
<b>(FR)</b>	<i>Régler les portes (ajuster les charnières)</i>
<b>(IT)</b>	<i>Sistemare le porte (regolare le cerniere)</i>
<b>(CZ)</b>	<i>Vyrovnejte dvířka (seřídte závěsy)</i>
<b>(SK)</b>	<i>Nastavenie dverí (nastavenie závesov)</i>
<b>(HU)</b>	<i>Állítsa be az ajtókat (állítsa be a zsanérokat)</i>
<b>(RO)</b>	<i>Reglare ușii (ajustare balamale)</i>

